



JOA-2160  
Linear Products Division  
JOA-EM4057  
Headquarters  
Research Center

Cat.No. **Lk001b**

**NITTO KOHKI'S**

# Air Compressors & Vacuum Pumps



- DC LINEAR Piston Compressor (Low Pressure Series)
- DC LINEAR Piston Vacuum Pump
- AC LINEAR Piston Compressor (Low Pressure Series)
- AC LINEAR Piston Compressor (Intermediate Pressure Series)
- AC LINEAR Piston Vacuum Pump
- AC LINEAR Piston Blower
- AC LINEAR Diaphragm Pump
- DC Diaphragm Pump
- DC Piston Pump
- AC LINEAR Air Compressor / Vacuum Pump / Diaphragm Pump (Made-to-order Item)

## Liquid Pumps

- Piezoelectric Pump
- Miniature Diaphragm Pump



Page

Quick Reference for Air Compressors & Vacuum Pumps	---	1
Quick Reference for Linear Motor Diaphragm Pumps	-----	2
Quick Reference for Linear Motor DC Pumps	-----	2
Features of the Linear Motor Free Piston System	-----	3
How to Use This Catalogue	-----	5
Precautions for Use	-----	6
Linear Motor Driven Free Piston Mechanism Applications	--	4
Conversion Tables	-----	7

# Air Compressors & Vacuum Pumps

## DC LINEAR Piston Compressor (Low Pressure Series)

Model	Rated Pressure			Max. Pressure			Rated Airflow		Page
	MPa (kgf/cm <sup>2</sup> )	bar	psig	MPa (kgf/cm <sup>2</sup> )	bar	psig	L/min	cfm	
DAH102-X1	0.02 {0.2}	0.2	2.84	0.05 {0.5}	0.5	7.11	5	0.177	9
DAH102-Y1	0.02 {0.2}	0.2	2.84	0.05 {0.5}	0.5	7.11	5	0.177	10
DAH105-X1	0.05 {0.5}	0.5	7.11	0.08 {0.8}	0.8	11.4	2.5	0.088	11
DAH105-Y1	0.05 {0.5}	0.5	7.11	0.08 {0.8}	0.8	11.4	2.5	0.088	12
DAH110-X1	0.1 {1.0}	1.0	14.2	0.12 {1.2}	1.2	17.1	1.0	0.035	13
DAH110-Y1	0.1 {1.0}	1.0	14.2	0.12 {1.2}	1.2	17.1	1.0	0.035	14

## DC LINEAR Piston Vacuum Pump

Model	Attainable Vacuum			Free Air Displacement		Page
	kPa (mmHg)	mbar	in.Hg	L/min	cfm	
DVH130-X1	-40 {-300}	-400	-11.8	7	0.247	17
DVH130-Y1	-40 {-300}	-400	-11.8	7	0.247	18
DVH145-X1	-60 {-450}	-600	-17.7	3	0.106	19
DVH145-Y1	-60 {-450}	-600	-17.7	3	0.106	20

## AC LINEAR Piston Compressor (Low Pressure Series)

Mark: Made-to-order

Model	Rated Pressure			Max. Pressure			Rated Airflow		Page
	MPa (kgf/cm <sup>2</sup> )	bar	psig	MPa (kgf/cm <sup>2</sup> )	bar	psig	L/min	cfm	
AC0102	0.02 {0.2}	0.2	2.84	0.04 {0.4}	0.4	5.69	5	0.177	23
AC0201A	0.01 {0.1}	0.1	1.42	0.02 {0.2}	0.2	2.84	20	0.71	24
AC0301A	0.01 {0.1}	0.1	1.42	0.03 {0.3}	0.3	4.27	28	0.99	25
AC0401A	0.01 {0.1}	0.1	1.42	0.035 {0.35}	0.35	4.98	35	1.24	26
AC0602	0.015 {0.15}	0.15	2.13	0.035 {0.35}	0.35	4.98	40	1.41	27
AC0901	0.01 {0.1}	0.1	1.42	0.04 {0.4}	0.4	5.69	80	2.83	28
AC0902	0.02 {0.2}	0.2	2.84	0.045 {0.45}	0.45	6.4	55	1.94	29
AC0501	0.01 {0.1}	0.1	1.42	0.035 {0.35}	0.35	4.98	45	1.59	95

## AC LINEAR Piston Compressor (Intermediate Pressure Series)

Model	Rated Pressure			Max. Pressure			Rated Airflow		Page
	MPa (kgf/cm <sup>2</sup> )	bar	psig	MPa (kgf/cm <sup>2</sup> )	bar	psig	L/min	cfm	
AC0105	0.05 {0.5}	0.5	7.1	0.08 {0.8}	0.8	11.4	2.5	0.088	31
AC0110	0.1 {1.0}	1.0	14.2	0.12 {1.2}	1.2	17.1	0.8	0.028	32
AC0207	0.07 {0.7}	0.7	9.96	0.1 {1.0}	1.0	14.2	3.5	0.124	33
AC0410A	0.1 {1.0}	1.0	14.2	0.13 {1.3}	1.3	18.5	5	0.177	34
AC0610A	0.1 {1.0}	1.0	14.2	0.15 {1.5}	1.5	21.3	8	0.283	35
AC0910	0.1 {1.0}	1.0	14.2	0.15 {1.5}	1.5	21.3	16	0.565	36
AC0920	0.2 {2.0}	2.0	28.4	0.3 {3.0}	3.0	42.6	8	0.283	37

## AC LINEAR Piston Vacuum Pump

Mark: Made-to-order

Model	Attainable Vacuum			Free Air Displacement		Page	
	kPa (mmHg)	mbar	in.Hg	L/min	cfm		
VP0125	-33.3 {-250}	-333	-9.84	7	0.247	39	
VP0140	-53.3 {-400}	-533	-15.7	3	0.106	40	
VP0435A	-46.7 {-350}	-467	-13.78	25	0.88	41	
VP0450	-66.7 {-500}	-667	-19.7	18	0.64	42	
VP0625	-33.3 {-250}	-333	-9.84	40	1.41	43	
VP0660	-80 {-600}	-800	-23.6	25	0.88	44	
VP0940	-53.3 {-400}	-533	-15.7	60	2.12	45	
VP0645	-60 {-450}	-600	-17.7	10	0.35	96	
VP0945	-60 {-450}	-600	-17.7	12	0.424	97	
VP0660x2	-93.3 {-700}	-933	-27.5	Series	25	0.88	98
	-80 {-600}	-800	-23.6	Parallel	50	1.77	

## AC LINEAR Piston Blower

Model	Rated Pressure			Rated Airflow		Page
	MPa (kgf/cm <sup>2</sup> )	bar	psig	L/min	cfm	
LA-28B	0.011 {0.11}	0.11	1.56	28	0.99	47
LA-45B	0.011 {0.11}	0.11	1.56	45	1.59	48
LA-60B	0.015 {0.15}	0.15	2.13	60	2.12	49
LA-80B	0.015 {0.15}	0.15	2.13	80	2.83	49
LA-100A	0.018 {0.18}	0.18	2.56	100	3.53	49
LA-120A	0.018 {0.18}	0.18	2.56	120	4.24	49
LAM-200	0.020 {0.20}	0.20	2.84	200	7.06	50

## AC LINEAR Diaphragm Pump

Mark: Made-to-order

Model	Max. Vacuum			Rated Pressure			Max. Pressure			Rated Airflow		Page
	kPa (mmHg)	mbar	in.Hg	MPa (kgf/cm <sup>2</sup> )	bar	psig	MPa (kgf/cm <sup>2</sup> )	bar	psig	L/min	cfm	
VC0100 Dual	-14.7 {-110}	-147	-4.33	0.004 {0.04}	0.04	0.57	0.016 {0.16}	0.16	2.28	6	0.21	53
VC0100 Blower				0.004 {0.04}	0.04	0.57	0.016 {0.16}	0.16	2.28	6	0.21	54
VC0101 Dual 120V	-18.7 {-140}	-187	-5.51	0.01 {0.1}	0.1	1.42	0.018 {0.18}	0.18	2.56	10	0.35	55
VC0101 Dual 230V	-10 {-76}	-100	-2.95	0.01 {0.1}	0.1	1.42	0.015 {0.15}	0.15	2.13	10	0.35	
VC0101 Blower				0.01 {0.1}	0.1	1.42	0.02 {0.2}	0.2	2.84	10	0.35	56
VC0101E Dual	-18.7 {-140}	-187	-5.51	0.01 {0.1}	0.1	1.42	0.02 {0.2}	0.2	2.84	15	0.53	57
VC0101E Blower				0.01 {0.1}	0.1	1.42	0.02 {0.2}	0.2	2.84	15	0.53	58
VC0101S Dual	-24 {-180}	-240	-7.08	0.005 {0.05}	0.05	0.71	0.026 {0.26}	0.26	3.70	15	0.53	99
VC0101S Blower				0.005 {0.05}	0.05	0.71	0.026 {0.26}	0.26	3.70	15	0.53	100
VC0201 Dual	-18.7 {-140}	-187	-5.5	0.01 {0.1}	0.1	1.42	0.018 {0.18}	0.18	2.56	20	0.71	59
VC0201 Blower				0.01 {0.1}	0.1	1.42	0.018 {0.18}	0.18	2.56	20	0.71	60
VC0301 Dual	-21.3 {-160}	-213	-6.3	0.01 {0.1}	0.1	1.42	0.02 {0.2}	0.2	2.84	25	0.88	61
VC0301 Blower				0.01 {0.1}	0.1	1.42	0.02 {0.2}	0.2	2.84	25	0.88	62
VC0201B Dual	-18.7 {-140}	-187	-5.5	0.01 {0.1}	0.1	1.42	0.018 {0.18}	0.18	2.56	20	0.71	63
VC0201B Blower				0.01 {0.1}	0.1	1.42	0.018 {0.18}	0.18	2.56	20	0.71	64
VC0301B Dual	-21.3 {-160}	-213	-6.3	0.01 {0.1}	0.1	1.42	0.02 {0.2}	0.2	2.84	25	0.88	65
VC0301B Blower				0.01 {0.1}	0.1	1.42	0.02 {0.2}	0.2	2.84	25	0.88	66

## DC Diaphragm Pump / DC Piston Pump

Model	Attainable Vacuum			Max. Pressure			Free Air Displacement		Page
	kPa (mmHg)	mbar	in.Hg	MPa (kgf/cm <sup>2</sup> )	bar	psig	L/min	cfm	
DP0125	-33.3 {-250}	-333	-9.84	0.03 {0.3}	0.3	4.27	2.5	0.088	69
DP0140	-53.3 {-400}	-533	-15.7	0.05 {0.5}	0.5	7.1	4	0.141	70
DP0102	-26.7 {-200}	-267	-7.87	0.045 {0.45}	0.45	6.4	5	0.177	71
DP0102S	-26.7 {-200}	-267	-7.87	0.045 {0.45}	0.45	6.4	7	0.247	72
DP0102H-X1	-50.7 {-380}	-507	-15	0.08 {0.8}	0.8	11.4	4	0.141	73
DP0102H-X2				0.08 {0.8}	0.8	11.4	4	0.141	74
DP0105-X1	-66.6 {-500}	-666	-19.7	0.25 {2.5}	2.5	35.6	2.8	0.1	75
DP0105-Y1	-66.6 {-500}	-666	-19.7	0.25 {2.5}	2.5	35.6	2.8	0.1	76
DPA0105-X1				0.22 {2.2}	2.2	31.3	2.8	0.1	77
DPA0105-Y1				0.22 {2.2}	2.2	31.3	2.8	0.1	78
DP0110-X1	-66.6 {-500}	-666	-19.7	0.15 {1.5}	1.5	21.3	7.5	0.26	79
DP0110-Y1	-66.6 {-500}	-666	-19.7	0.15 {1.5}	1.5	21.3	7.5	0.26	80
DP0110PWM	-66.6 {-500}	-666	-19.7	0.15 {1.5}	1.5	21.3	7.5	0.26	81

## PIEZOELECTRIC PUMP

Model	Discharge Pressure		Flow Rate		Self-priming Pressure		Page
	kPa	psi	mL/min	psi	kPa	psi	
<b>120V AC 60Hz</b>							
BPS-215i	15	15	30	3	3	3	83
BPS-235G	15	15	30	1.5	1.5	1.5	
BPH-214i	18	18	350	8	8	8	
BPH-214D	18	18	350	8	8	8	
BPH-214E	18	18	350	8	8	8	
BPH-214G	17	17	350	7	7	7	
BPH-414i	35	35	500	12	12	12	
BPH-414D	35	35	500	12	12	12	
BPH-414E	35	35	500	12	12	12	
BPH-414G	32	32	450	10	10	10	
BPH-474G	35	35	400	10	10	10	
BPH-474P	35	35	400	10	10	10	
BPH-465P	35	35	400	10	10	10	
<b>230V AC 50Hz</b>							
BPS-215i	10	10	10	0.4	0.4	0.4	84
BPS-235G	10	10	10	0.4	0.4	0.4	
BPH-214i	18	18	220	8	8	8	
BPH-214D	18	18	220	8	8	8	
BPH-214E	18	18	220	8	8	8	
BPH-214G	17	17	220	7	7	7	
BPH-274G	35	35	250	7	7	7	
BPH-274P	35	35	250	7	7	7	
BPF-265P	35	35	250	7	7	7	

## MINIATURE DIAPHRAGM PUMP

Model	Working Pressure			Flow Rate		Self-priming Pressure		Page
	kPa	bar	psig	mL/min	cfm	kPa	psi	
DPE-100	100	1	14.5	100	0.0035	20	20	88
DPE-400	100	1	14.5	400	0.0141	40	40	89
DPE-400BL	100	1	14.5	400	0.0141	40	40	90
DPE-800	100	1	14.5	800	0.0282	40	40	91

## VACUUM TWEEZERS

Model	Page
MEDO HAND Model MH-100A	93

# LINEAR MOTOR DRIVEN FREE PISTON MECHANISM

The Linear-motor-driven Free Piston System is not only ideal for upgrading existing systems but can also be used for future design improvement. Compact, quiet, and vibration free, the extremely reliable Free Piston Pump will enhance your system performance and extend its operating life.

The Electro-magnet and return spring alternatively drive the piston inside the cylinder, the mechanical resonance of which is synchronized with the input current cycle. In a single mechanism, the piston combines the functions of two normally independent devices; a pump and a motor.

### Compact integrated design

This unique system enables the mechanical resonance of a single part. An incredibly compact, lightweight design is achieved by combining what are entirely independent functions in conventional pumps - the motor and the compressor - into a superior single, unified structure.

A silicon diode in between the coils converts the full-wave input current into half-rectified current. In turn this activates and deactivates the electro-magnet, producing a smooth mechanically resonating action.

### Operating Principle

A. The energised electro-magnet attracts the piston, compresses the return spring, and draws air into the cylinder through the opened inlet valve.

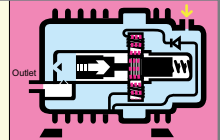

### Current



### No Current



B. When the electro-magnet is de-energized, the return spring pushes the piston back, forcing the compressed air out of the cylinder through the now opened outlet valve.

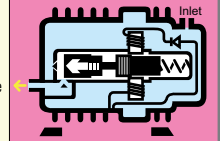

### Fewer components

This uniquely simple and reliable design has no complicated transmission components such as crankshafts, connecting rods, ball bearings, etc. typically found in conventional pump designs. Fewer parts means fewer problems.

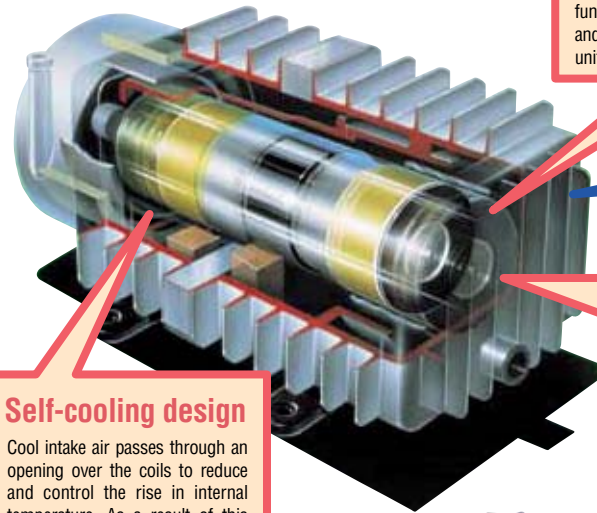

### Self-cooling design

Cool intake air passes through an opening over the coils to reduce and control the rise in internal temperature. As a result of this feature, it is possible to almost completely seal the unit, thus improving the suppression of internal operating noise.

### Hyper pressure control mechanism

Should the output pressure exceed the rated value, the piston will automatically adjust to a shorter stroke. Additionally, power consumption will automatically reduce, guarding against possible temperature overloads.



## Air Compressors & Vacuum Pumps



Air Brush



Soldering Fume Remover



Muscular Electro-Therapy Unit



Aquarium Aeration



Coffee Maker



Pap smear Tester



Nebulizers

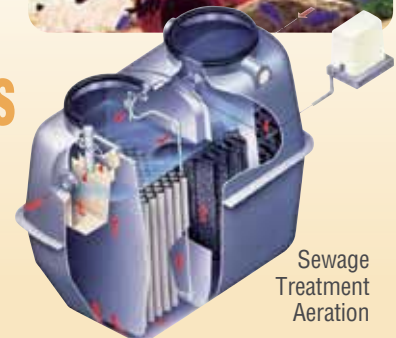

Sewage Treatment Aeration

## Our Valued Customers & Applications

**Experience gained in well over two decades of designing, engineering, manufacturing and continually perfecting our products in thousands of applications has resulted in a “functionally intelligent” package. Please review these key design features and see how every design element contributes overall to the creation of a superior compressor or vacuum pump.**



**Compact and Lightweight with the motor and compressor combined into the single structure**

With the piston as the only moving part, efficient space utilisation enables our pump to be considerably smaller and lighter than other pumps. This allows the OEM design engineer increased packaging options for other internal components.



**Low Noise Level No transmission assemblies, means less noise**

With no need for complicated transmission mechanisms riding on ball bearings, or actuating linkages creating friction and noise, Nitto Kohki's pumps are inherently quieter. Additionally, the almost completely sealed configuration further suppresses secondary internal operating noises.



**Low Vibration using an ultra-lightweight piston**

The extremely low mass, short stroke, die cast piston minimises reactive force vibrations. Secondary vibrations are isolated or absorbed through the soft elastomeric mounting pads.



**Clean Operation - Clean Air due to oil-less construction**

All wearing surfaces use no oil, grease or other contaminating lubricants. The combination of a precision Teflon® sleeved piston assisted by an "air-bearing effect" made possible through a unique air path design, assures that the outlet air is completely free of oil.



**Instant Response enabling easy start-ups in frequent on-off short cycle applications**

A very low starting current enables our pumps to produce immediate performance in quick short cycle applications, even in the presence of residual back pressure.



**Minimal Pulsating Effect due to the high resonating speed**

The piston's mechanical resonance speed is synchronised with the input power frequency regardless of the load, i.e., 3000 strokes at 50Hz, and 3600 strokes at 60Hz per minute. This high speed produces shorter pulses which translate into a smoother, more uniform and "linear" motion.



**Automatic Pressure Adjustment with intelligent pressure monitoring**

Should an operating condition create excessive pressure, the piston stroke length proportionally reduces to accommodate the condition. Along with this adjustment, power consumption is correspondingly reduced, decreasing or eliminating the potential for system malfunctions or permanent damage.



**Low Power Consumption truly energy efficient through integrated design**

Since the low mass piston is the only moving part, frictional losses are minimised, allowing lower starting and running current, and thus greater efficiency. Related benefits are realised through a lower rise in temperature, facilitating a longer operating life for the pump and the other components within your system.



**Longer Durability increased OEM value**

All key design features listed here combine to provide superior performance in all the important aspects of superior pump design. This enables the OEM engineer to have complete confidence in incorporating the unit into the most demanding systems, in the most advanced equipment.



**Easy maintenance only air filter and piston to change**

Replacement of the piston can be easily performed by simply removing the four screws holding the head cover in place. A completely oil-less construction is achieved through the combination of two elements: the superior abrasion resistance of the Teflon® seals that cover the piston contact surfaces and the "air bearing effect" created by the unique air path design.

# How to Use This Catalog

This catalogue is designed to aid you in selecting the most appropriate product for your specific application. The INDEXES on page 1 and 2 show the corresponding pages of particular models. The page on which each

model is shown consists of a specification table, a performance chart, a power consumption chart, and an external/mounting dimensions diagram.

## Explanation of Technical Terms

### For compressors

<b>Rated pressure:</b>	This is the optimum pressure point, where you will get the best capabilities such as performance and service life, and where the pump is designed to have almost the same airflow regardless of input cycle, whether it is 50Hz or 60Hz.
<b>Rated airflow:</b>	The discharge airflow volume at the rated pressure.
<b>Maximum pressure:</b>	The highest obtainable pressure at which the pump was designed to produce zero discharge airflow (not assured; referential value only).
<b>Power consumption:</b>	The input wattage value during operation at the rated pressure.
<b>Current:</b>	The electric current value when operated at rated pressure (for reference only).
<b>Duty cycle:</b>	The period of operation time in which the coil temperature will not exceed the coil insulation class limit for which it was designed.
<b>Airflow characteristics:</b>	Discharge pressure-airflow curve (for reference only).
<b>Power consumption characteristics:</b>	Discharge pressure-power consumption curve (for reference only).

### For vacuum pumps

<b>Maximum vacuum:</b>	The highest vacuum the pump can attain with the pump inlet closed (except some of the exclusive models).
<b>Free air displacement:</b>	The airflow volume at zero vacuum (within three (3) minutes after the start).
<b>Power consumption:</b>	The maximum input wattage on the power consumption curve (up to the maximum vacuum point).
<b>Electric current:</b>	The maximum electric current on the current characteristics (for reference only).
<b>Rated operating time:</b>	The longest continuous running time within the range of coil insulation classification (without additional cooling).
<b>Airflow characteristics:</b>	Vacuum degree-airflow curve (for reference only).
<b>Power consumption characteristics:</b>	Vacuum degree-power consumption curve (for reference).
<b>Exhaust characteristics:</b>	The time required to attain the respective vacuum within a 10 liter container (for reference).

### For DC pumps

<b>Operating ambient temperature:</b>	0~40°C ( 5~50°C for only DP0105 )
<b>Operating ambient humidity:</b>	30~85% without condensation present

Verify in your application if the pump outlet must be unloaded before restarting.

### Application examples and applicable fluids for compressors and vacuum pumps

**Application:** for incorporation into equipment    **Applicable fluid:** Air

### For compressors & vacuum pumps

**Life expectancy:** Expected accumulated operating hours until the discharge airflow reduces by 20% under rated conditions. The actual life might vary in accordance with the actual operating conditions or environment such as output pressure setting, maintenance schedule, ventilation, ambient temperature, duty cycle, etc.  
Please note that operation with quite different supply voltage than the rated will not only affect the pressure, the vacuum rate and the airflow but may also influence the life expectancy of the pump.

**Rated frequency:** In the case of AC drive, the rated frequency will be different by the versions, some are only for 50Hz or for 60Hz, some are for both 50Hz and 60Hz.

**Coil insulations:** The suggested classe, most bare units attaining "E" class, is based on Japanese electric regulations. They are merely suggestions since bare units are considered as "components" and are not classified as complete products or systems.

Insulation Class (for reference)	(Temperature limit, degrees C)
A	100
E	115
B	125
F	150
H	170

**Outside & mounting dimensions:** Useful for assessing the required space for installation. Allow extra 5-10 mm each in order to prevent the pump from hitting its surroundings as it vibrates on rubber insulating feet.

**Rated power supply:** The two major types are 115V AC/60Hz and 230V AC/50Hz. However, most of the models, not all of them, can be used at both 50Hz and 60Hz with different performance characteristics.

**Operating ambient temperature:** 0 ~ 40°C

**Operating ambient humidity:** 30 ~ 85% non-condensing

### For liquid pumps

**Self-priming power:** The power that the pump will draw 25°C water up.  
1kPa is equal to the power that draws up 25°C water by 10cm.

### Improvement suggestion

While our compressors and vacuum pumps employ a unique internal coil cooling feature to reduce or control the rise in internal temperature, please be advised that operating at higher than rated pressures may result in elevated temperatures. Should these temperatures become excessive, operating duty cycles may need to be reduced, or the use of an auxiliary cooling fan should be considered.

This catalogue will give the guidelines to let you determine the appropriate model for your application(s). However, in certain cases you may need further detailed information, which will be provided in the form of a specifications sheet for each model/version by our technical staff who will further assist you in your selection.

**Specifications and designs are subject to change at any time without notice.**

**It is recommended for OEM customers to confirm the specifications required in writing before placing orders.**

# Precautions for Use

Before using any of our products, please be sure to read the following precautions and the product's operation manual.

## Precautions for Compressors

### CAUTION

- **The unit must be used as assembled in a device that has the appropriate casing and wiring.**  
Using it without appropriate casing may cause fire, electric shock or burns.
- **Do not give the unit heavy external shock during storage and transportation,**  
which may cause malfunction of the unit.
- **Do not use the unit with a power supply other than the voltage shown on the unit.**  
Negligence may cause a fire or an electric shock.
- **Do not install the unit in a completely enclosed case (box) without proper or adequate ventilation.**  
This may cause a fire or an electric shock.
- **Use the unit within the proposed ambient temperature range.**  
Using it out of the range may cause a fire or an electric shock.
- **Units must not be modified.**  
Modification may cause a fire or an electric shock.
- **Do not place flammable substances near the unit.**  
This may cause a fire.
- **Units with grounding screws should be earthed (grounded), except when connected to a double insulation device.**  
Not earthing the unit may result in a fire or an electric shock.

### WARNING

**Do not let the unit take in any gas other than air.**  
There is a risk of an explosion, fire or electric shock.

**Make sure the unit is operated in a completely dry area.**  
There is the risk of a short circuit causing a fire or an electric shock.

- **The unit must be installed at a level higher than the water surface when it is used for bubbling.**  
If installed at a lower level, fluid may flow into the unit and cause an electric shock.
- **Do not allow anything to be placed on or to fall onto the electric cable,**  
which may damage the cable, causing a fire or an electric shock.
- **Do not pull, cut, twist, heat up or unnecessarily bend the electric cable,**  
which may damage the cable, causing a fire or an electric shock.
- **When installing the unit into another device, the cable from the unit should be connected securely to the wiring of the device by such as soldering, crimping or screw fasteners.**  
A loose connection may cause a fire or an electric shock.
- **The unit must not be disassembled or repaired by any other person than who has received Nitto Kohki technical training. (Except in the case of filter and piston maintenance and inspection in accordance with the operation manual.)**  
Otherwise it may result in a fire or an electric shock due to faulty operation.
- **The unit must be disconnected from its power source before the cleaning or replacing filters.**  
Failure to do so may result in an electric shock or injury.

## Precautions for Vacuum Pumps

### CAUTION

- **Do not install the unit in a completely enclosed case (box).**  
This may cause a fire or an electric shock.
- **The unit must be used as assembled in a device that has the appropriate casing and wiring.**  
Using it without appropriate casing may cause fire, electric shock or burns.
- **Do not give the unit heavy external shock during storage and transportation,**  
which may cause malfunction of the unit.
- **Do not use the unit with a power supply other than the voltage shown on the unit.**  
Negligence may cause a fire or an electric shock.
- **Use the unit within the proposed ambient temperature range.**  
Using it out of the range may cause a fire or an electric shock.
- **Units must not be modified.**  
Modification may cause a fire or an electric shock.
- **Do not place flammable substances near the unit.**  
This may cause a fire.
- **In case there is a chance of moisture, particles, dirt or dust in the air the unit suck in, an additional filtration device must also be installed on the inlet port of the unit.**  
Contaminated air may cause an electric shock.
- **Units with grounding screws should be earthed (grounded), except when**

### WARNING

**Do not let the unit take in any gas other than air.**  
There is a risk of an explosion, fire or electric shock.

**Make sure the unit is operated in a completely dry area.**  
There is the risk of a short circuit causing a fire or an electric shock.

- connected to a double insulation device.  
Not earthing the unit may result in a fire or an electric shock.
- **The unit must be installed at a level higher than the water surface when it is used for bubbling.**  
If installed at a lower level, fluid may flow into the unit and cause an electric shock.
- **Do not allow anything to be placed on or to fall onto the electric cable,**  
which may damage the cable, causing a fire or an electric shock.
- **Do not pull, cut, twist, heat up or unnecessarily bend the electric cable,**  
which may damage the cable, causing a fire or an electric shock.
- **When installing the unit into another device, the cable from the unit should be connected securely to the wiring of the device by such as soldering, crimping or screw fasteners.**  
A loose connection may cause a fire or an electric shock.
- **The unit must not be disassembled or repaired by any other person than who has received Nitto Kohki technical training. (Except in the case of filter and piston maintenance and inspection in accordance with the operation manual.)**  
Otherwise it may result in a fire or an electric shock due to faulty operation.
- **The unit must be disconnected from its power source before the cleaning or replacing filters.**  
Failure to do so may result in an electric shock or injury.

## Precautions for Blowers

### CAUTION

- **Do not place the unit on the spot where may be soaked with water or covered with snow.**  
This may cause an electric shock or a fire.
- **Do not use the unit in a damp or wet place.**  
This may cause an electric shock or fire.
- **Always place the unit above water level.**  
Failure to do so may result in an electric shock or fire.
- **Use a waterproof wall outlet socket to supply power to the unit.**  
Failure to do so may cause an electric shock or fire.
- **Use a power supply equipped with a set of earth leakage and overcurrent breakers.**  
Failure to do so may result in an electric shock or fire.
- **Electric work must be done by a qualified electrician.**  
Failure to do so may result in an electric shock or fire.
- **Do not modify the unit.**  
Modification may cause a fire or an electric shock.
- **Do not use with the outlet port closed or at free displacement.**  
This may cause an electric shock, malfunction, or fire.
- **Do not use the unit with a power supply other than the voltage shown on the unit.**  
Negligence may cause a fire or an electric shock.
- **Never touch the power plug with wet hands.**  
This may cause an electric shock.

### WARNING

**Do not let the unit take in any gas other than air.**  
There is a risk of an explosion, fire or electric shock.

- **Insert the power plug securely to the hilt of the contact blades so that it does not wobble.**  
Failure to do so may result in an electric shock.
- **Do not put anything on the power cable.**  
This may cause a fire or an electric shock.
- **Do not place anything near the unit (within 50cm reach)**  
This may cause a fire or an electric shock.
- **Do not use the unit where flammables, such as gasoline, solvents, lacquer, benzene, etc. are being used.**  
This may cause a fire or an explosion.
- **Check the power plug at least once a year for dirt and dust and clean.**  
Failure to do so may result in an electric shock or a fire.
- **The power plug must be disconnected before the air filter is cleaned or replaced.**  
Negligence may cause an electric shock or accident.
- **Always grasp the power plug not the cable when disconnecting the unit from the power socket.**  
Pulling it out by grasping the cable may cause an electric shock or short circuit.
- **Any disassembled air filter must be put back before resuming the operation.**  
Negligence may cause a fire or an electric shock.
- **Never try to disassemble or repair the unit.**  
This may cause an electric shock or an injury. Any repairs must be done by an electrician authorized by Nitto distributors.
- **Do not cover Blower with a box or the like without proper or adequate ventilation.**  
This may cause malfunction and fire.

## Precautions for Liquid Pumps

### CAUTION

- **Please avoid any liquid that contaminated with solids such as debris or dust.**  
If dust sticks to the valve, the unit may not give a good performance. When intrusion of dust is expected, place a filter to the inlet.
- **Please avoid any liquid that may crystallize.**  
If crystals stick to the valve, the unit may not give a good performance. Preparatory test on the unit with the liquid is recommended.

### WARNING

**Please confirm the suitability of the liquid that passes through the unit before use.**  
Otherwise there will be possible leak, burst, fire or electric shock.

- **The performance is measured with the unit at its proper position, which is described in the user's manual. Different unit positions or the nozzle directions may result in different performances.**

## When in use of compressors and vacuum pumps

As compressors and vacuum pumps employ self-cooling system, if used at more than rated pressure, **duty cycle of some of the models will be shortened.**

- When you want to prolong the duty cycle, it is recommended for you to cool the compressor with fans. For instance, AC0902, whose duty cycle is 30 minutes, is effective.

Please check with our distributor in advance if you like to use the compressor/vacuum pump at free displacement (OMPa), or the vacuum pump with inlet port closed, or the compressor at maximum pressure.

- Do not use the compressor near flammable gas.
- Do not use the compressor in the rain or in wet and damped place.
- Do not suck corrosive gas.

- Be sure to install and use the compressor at a position higher than water level.

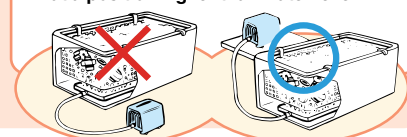

## Handling Problems

In any of the right cases, **stop operation immediately**, switch off the power and disconnect the unit from the power supply. Ask our distributor for repair.

- When **oil such as lubricant** has been applied to the unit in error.
- When the unit has suffered a severe **shock such as being dropped.**
- When **liquid such as water** has entered into the unit by mistake.

- When an **abnormal operation** is observed, such as the emission of smoke, or an unusual smell or noise.

# Conversion Tables

## Pressure / Flow Rate / Vacuum

### Pressure

MPa	kgf/cm <sup>2</sup> (bar)	psig
0.30	3.0	42.7
0.28	2.8	39.8
0.25	2.5	35.6
0.20	2.0	28.5
0.18	1.8	25.6
0.15	1.5	21.3
0.12	1.2	17.1
<b>0.10</b>	<b>1.0</b>	<b>14.2</b>
0.08	0.8	11.4
0.07	0.7	9.96
0.05	0.5	7.11
0.045	0.45	6.40
0.04	0.4	5.69
0.035	0.35	4.98
0.034	0.34	4.84
0.03	0.3	4.27
0.02	0.2	2.84
0.018	0.18	2.56
0.015	0.15	2.13
0.011	0.11	1.56
0.01	0.1	1.42
<b>0.007</b>	<b>0.07</b>	<b>1.00</b>
0.005	0.05	0.71
* 0	0	0

### Flow Rate

CFM	LPM	CFM	LPM
<b>0.035</b>	<b>1.00</b>	2.12	60.0
0.070	2.00	2.25	63.7
0.100	2.83	2.47	70.0
0.105	3.00	2.50	70.8
0.177	5.00	2.65	75.0
0.250	7.08	2.75	77.9
0.353	10.0	2.83	80.0
0.500	14.2	3.00	85.0
0.530	15.0	3.18	90.0
0.708	20.0	3.25	92.0
0.750	21.2	3.50	99.1
0.883	25.0	3.53	100
<b>1.00</b>	<b>28.32</b>	3.75	106
1.06	30.0	3.89	110
1.24	35.0	4.00	113
1.25	35.4	4.24	120
1.41	40.0	4.50	127
1.50	42.5	5.00	142
1.59	45.0	5.30	150
1.75	49.6	6.00	170
1.77	50.0	7.00	198
2.00	56.6	7.06	200

### Vacuum

kPa	mmHg	mbar	in.Hg
* 0	0	0	0
-13.3	-100	-133	-3.94
-26.7	-200	-267	-7.87
-33.3	-250	-333	-9.84
-44.0	-330	-440	-13.0
-45.3	-340	-453	-13.4
-46.7	-350	-467	-13.8
-53.3	-400	-533	-15.7
-60.0	-450	-600	-17.7
-66.7	-500	-667	-19.7
-73.3	-550	-733	-21.7
-80.0	-600	-800	-23.6
-93.3	-700	-933	-27.6
-100	-750	-1000	-29.5
** -101.3	-760	-1013	-29.9

### Pressure

to \ from	MPa	kgf/cm <sup>2</sup>	bar	psig
MPa	1	10	10	142
kgf/cm <sup>2</sup>	0.1	1	1	14.2
bar	0.1	1	1	14.2
psig	0.007	0.07	0.07	1

### Vacuum

to \ from	kPa	mmHg	in.Hg	mbar
kPa	-1	-7.50	-0.295	-10
mmHg	-0.133	-1	-0.0394	-1.335
in. Hg	-3.39	-25.4	-1	-33.92
mbar	-0.1	-0.75	-0.0295	-1

\* Gauge pressure  
 \*\* Absolute vacuum





**AIR COMPRESSOR**

# **DC** Low Pressure Series

# **LINEAR**

## **Piston Compressor**

DAH102-X1  
P9

DAH102-Y1  
P10

DAH105-X1  
P11

DAH105-Y1  
P12

DAH110-X1  
P13

DAH110-Y1  
P14

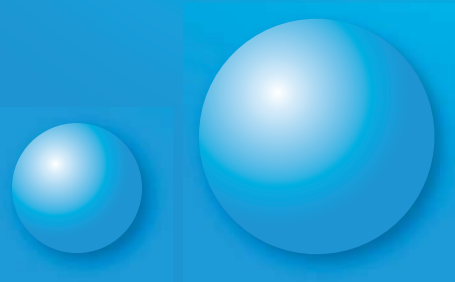

COMPRESSOR

# LINEAR Piston DC



MOTOR FREE  
PISTON SYSTEM

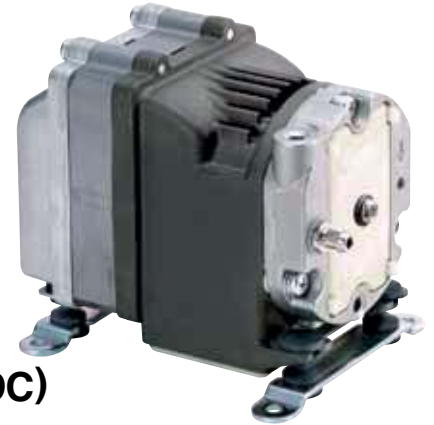

# DAH102-X1 (12 V DC)

## Airflow & Electric Current

## Specifications

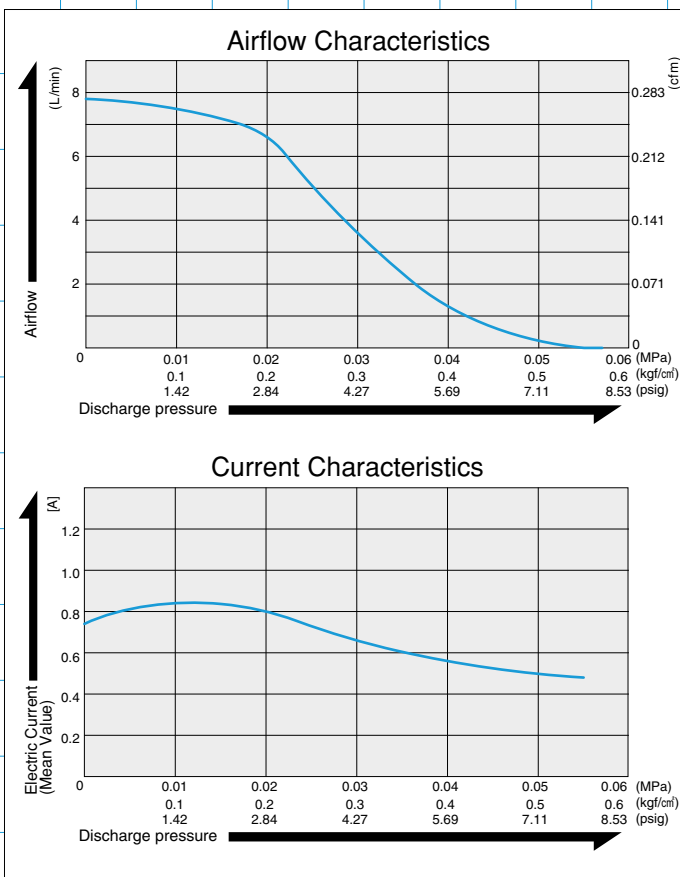

	(SI)	(EURO)	(U.S.A.)
Rated Pressure	0.02 MPa {0.2 kgf/cm <sup>2</sup> }	0.2 bar	2.84 psig
Rated Airflow	5 L/min ※1		0.177 cfm
Rated Voltage	12 V DC		
Maximum Pressure	0.05 MPa {0.5 kgf/cm <sup>2</sup> }	0.5 bar	7.11 psig
Current (Mean Value)	0.81A		
Life Expectancy	10,000 hours		
Outlet	6 mm O.D. hose barb		
Duty Cycle	Continuous		
Coil Insulation Class	A or its equivalent		
Mounting Dimensions	76 mm(L) x 70 mm(W)	3"(L) x 2-3/4"(W)	
Gross Weight	0.91 kg	2.01 Lbs.	
Leadwire Length	300 mm	11-13/16"	

※1: Air displacement at rated pressure.  
Please read the page of "How to Use This Catalog" first for correct use of compressors and pumps.

## General Conditions

Ambient Temperature: 0 ~ 40°C  
Ambient Humidity: 30 ~ 85%  
Fluid: Air

## Applications

Medical equipment, analyzers, etc.

Heavy duty rubber feet available on request. To prevent drop damage when located within portable devices.

## Sketch Drawing and Mounting Dimensions Diagram (mm)

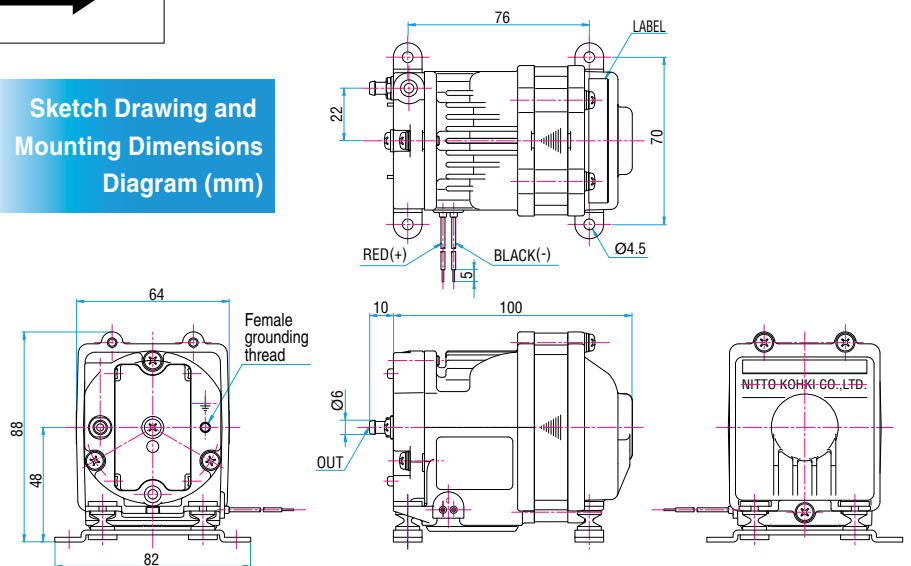

COMPRESSOR

# LINEAR Piston DC



MOTOR FREE  
PISTON SYSTEM



# DAH102-Y1 (24 V DC)

## Airflow & Electric Current

## Specifications

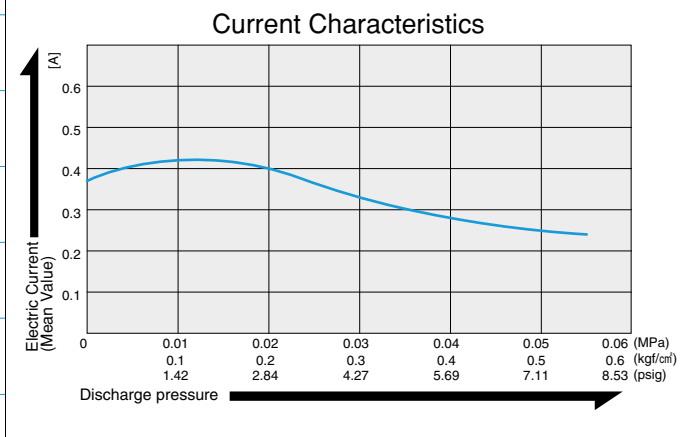
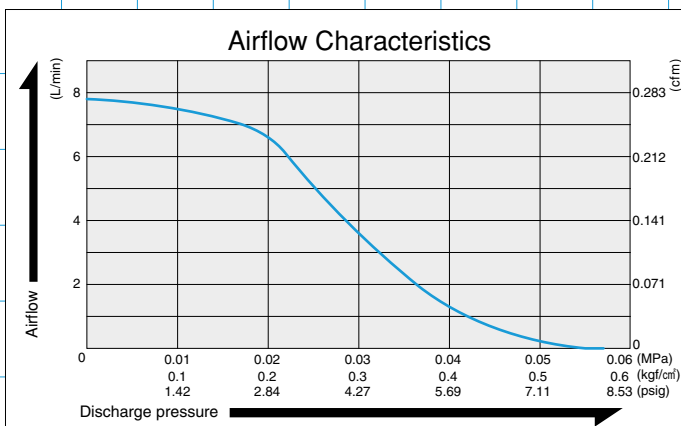

	(SI)	(EURO)	(U.S.A.)
Rated Pressure	0.02 MPa {0.2 kgf/cm <sup>2</sup> }	0.2 bar	2.84 psig
Rated Airflow	5 L/min <sup>※1</sup>		0.177 cfm
Rated Voltage	24 V DC		
Maximum Pressure	0.05 MPa {0.5 kgf/cm <sup>2</sup> }	0.5 bar	7.11 psig
Current (Mean Value)	0.40A		
Life Expectancy	10,000 hours		
Outlet	6 mm O.D. hose barb		
Duty Cycle	Continuous		
Coil Insulation Class	A or its equivalent		
Mounting Dimensions	76 mm(L) x 70 mm(W)	3"(L) x 2-3/4"(W)	
Gross Weight	0.91 kg	2.01 Lbs.	
Leadwire Length	300 mm	11-13/16"	

※1: Air displacement at rated pressure.

Please read the page of "How to Use This Catalog" first for correct use of compressors and pumps.

### General Conditions

Ambient Temperature: 0 ~ 40°C  
Ambient Humidity: 30 ~ 85%  
Fluid: Air

### Applications

Medical equipment, analyzers, etc.

Heavy duty rubber feet available on request.  
To prevent drop damage when located within portable devices.



### Sketch Drawing and Mounting Dimensions Diagram (mm)

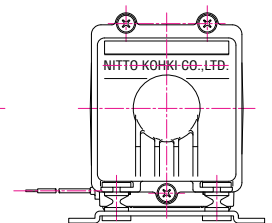
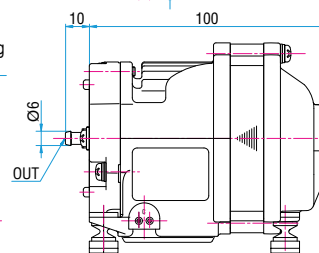
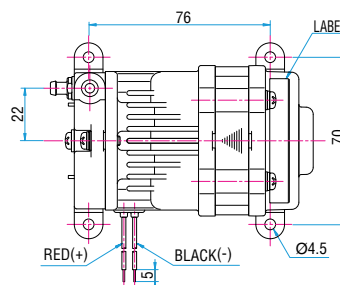
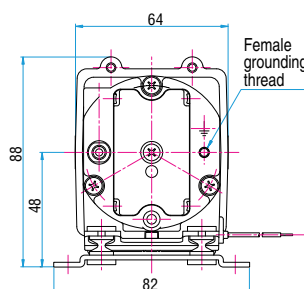

COMPRESSOR

# LINEAR Piston DC



MOTOR FREE  
PISTON SYSTEM



# DAH105-x1 (12 V DC)

Airflow & Electric Current

Specifications

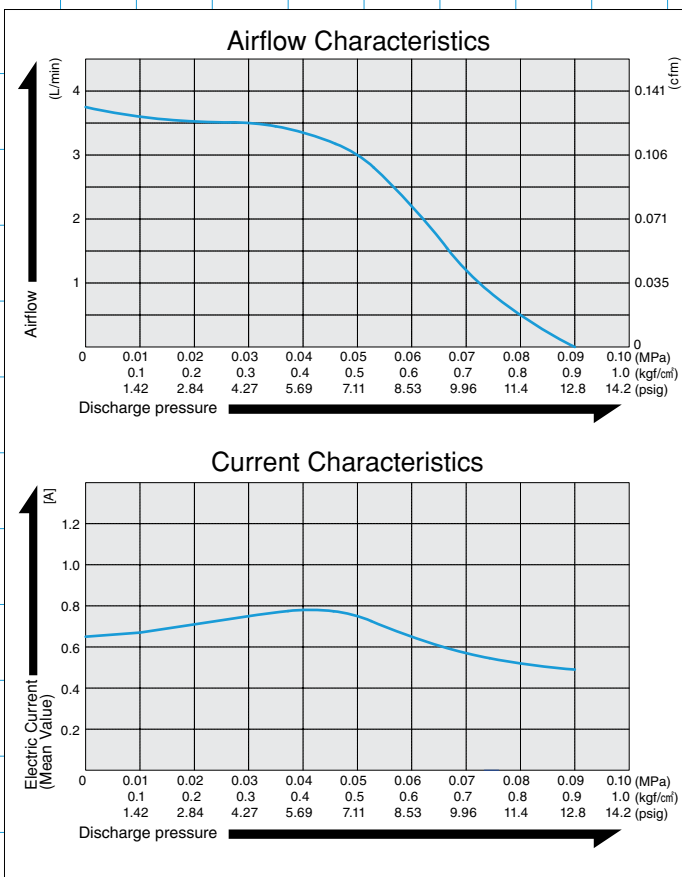

	(SI)	(EURO)	(U.S.A.)
Rated Pressure	0.05 MPa {0.5 kgf/cm <sup>2</sup> }	0.5 bar	7.11 psig
Rated Airflow	2.5 L/min <sup>※1</sup>		0.088 cfm
Rated Voltage	12 V DC		
Maximum Pressure	0.08 MPa {0.8 kgf/cm <sup>2</sup> }	0.8 bar	11.4 psig
Current (Mean Value)	0.74A		
Life Expectancy	10,000 hours		
Outlet	6 mm O.D. hose barb		
Duty Cycle	Continuous		
Coil Insulation Class	A or its equivalent		
Mounting Dimensions	76 mm(L) x 70 mm(W)	3"(L) x 2-3/4"(W)	
Gross Weight	0.91 kg	2.01 Lbs.	
Leadwire Length	300 mm	11-13/16"	

※1: Air displacement at rated pressure.  
Please read the page of "How to Use This Catalog" first for correct use of compressors and pumps.

General Conditions

Ambient Temperature: 0 ~ 40°C  
Ambient Humidity: 30 ~ 85%  
Fluid: Air

Applications

Medical equipment, analyzers, etc.

Heavy duty rubber feet available on request. To prevent drop damage when located within portable devices.

Sketch Drawing and Mounting Dimensions Diagram (mm)

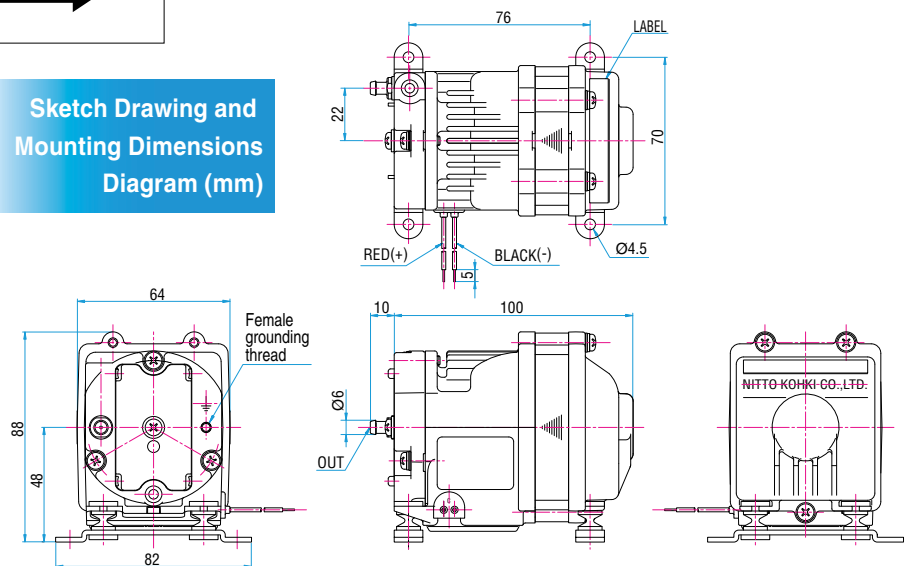

COMPRESSOR

# LINEAR Piston DC



MOTOR FREE  
PISTON SYSTEM



# DAH105-Y1 (24 V DC)

Airflow & Electric Current

Specifications

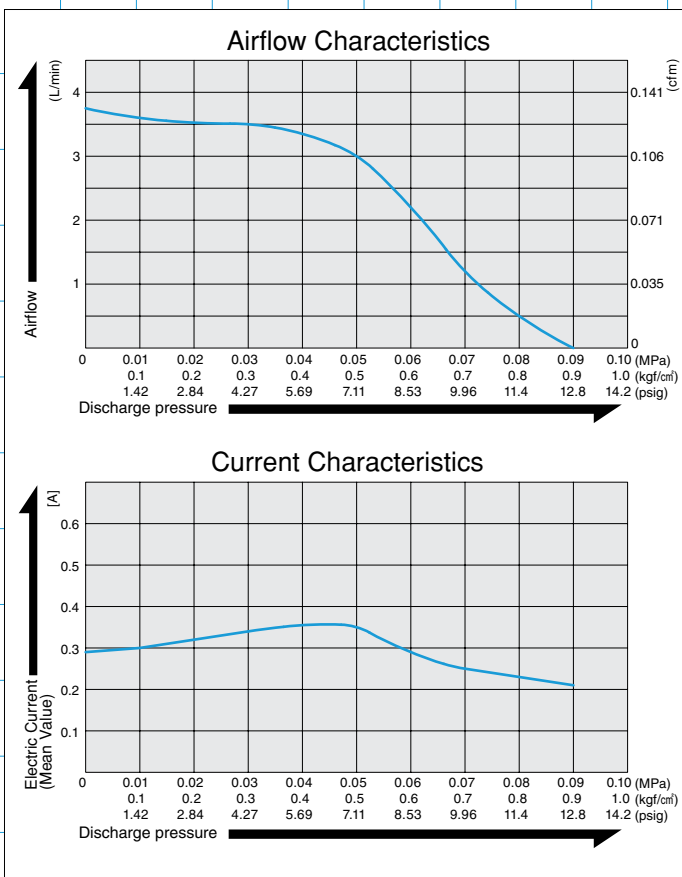

	(SI)	(EURO)	(U.S.A.)
Rated Pressure	0.05 MPa {0.5 kgf/cm <sup>2</sup> }	0.5 bar	7.11 psig
Rated Airflow	2.5 L/min <sup>※1</sup>		0.088 cfm
Rated Voltage	24 V DC		
Maximum Pressure	0.08 MPa {0.8 kgf/cm <sup>2</sup> }	0.8 bar	11.4 psig
Current (Mean Value)	0.35A		
Life Expectancy	10,000 hours		
Outlet	6 mm O.D. hose barb		
Duty Cycle	Continuous		
Coil Insulation Class	A or its equivalent		
Mounting Dimensions	76 mm(L) x 70 mm(W)	3"(L) x 2-3/4"(W)	
Gross Weight	0.91 kg	2.01 Lbs.	
Leadwire Length	300 mm	11-13/16"	

※1: Air displacement at rated pressure.  
Please read the page of "How to Use This Catalog" first for correct use of compressors and pumps.

General Conditions

Ambient Temperature: 0 ~ 40°C  
Ambient Humidity: 30 ~ 85%  
Fluid: Air

Applications

Medical equipment, analyzers, etc.

Heavy duty rubber feet available on request. To prevent drop damage when located within portable devices.

Sketch Drawing and Mounting Dimensions Diagram (mm)

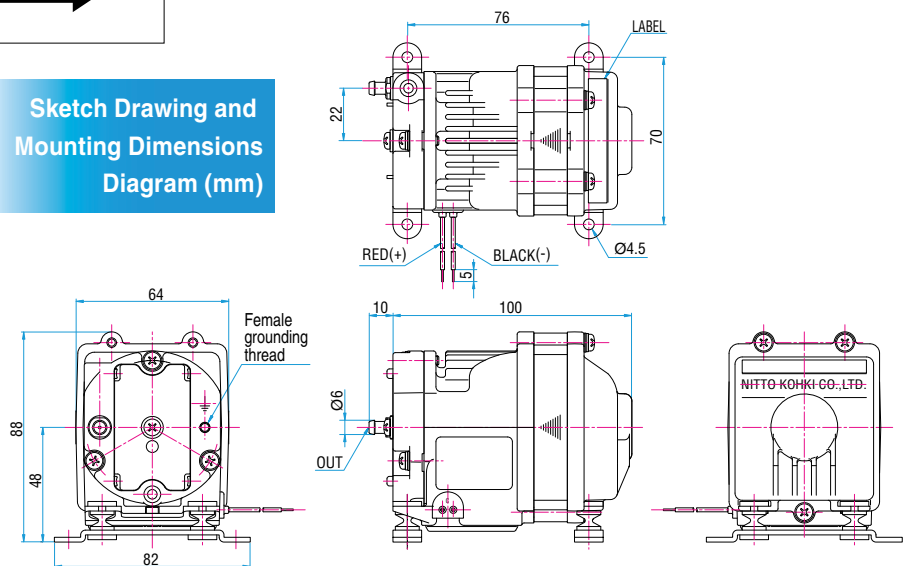

COMPRESSOR

# LINEAR Piston DC



MOTOR FREE  
PISTON SYSTEM

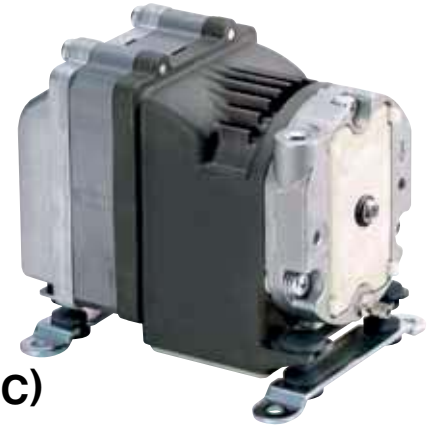

# DAH110-X1 (12 V DC)

Airflow & Electric Current

Specifications

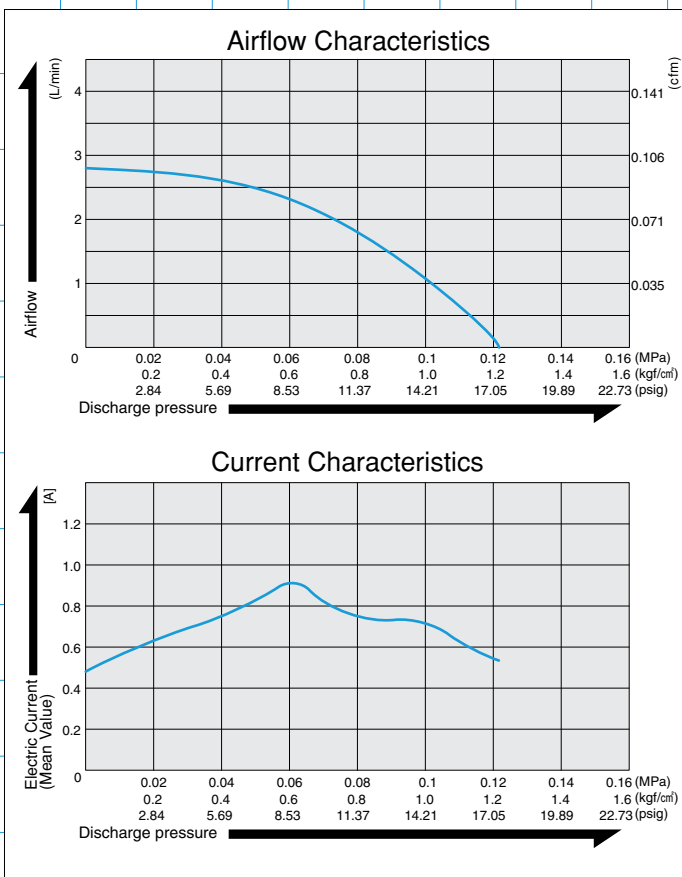

	(SI)	(EURO)	(U.S.A.)
Rated Pressure	0.1 MPa {1.0 kgf/cm <sup>2</sup> }	1.0 bar	14.2 psig
Rated Airflow	1.0 L/min <sup>※1</sup>		0.035 cfm
Rated Voltage	12 V DC		
Maximum Pressure	0.12 MPa {1.2 kgf/cm <sup>2</sup> }	1.2 bar	17.1 psig
Current (Mean Value)	0.74A		
Life Expectancy	5,000 hours ( MTTF )		
Outlet	4.7 mm O.D. hose barb		
Duty Cycle	Continuous		
Coil Insulation Class	A or its equivalent		
Mounting Dimensions	76 mm(L) x 70 mm(W)	3"(L) x 2-3/4"(W)	
Gross Weight	0.91 kg	2.01 Lbs.	
Leadwire Length	300 mm	11-13/16"	

※1: Air displacement at rated pressure.  
Please read the page of "How to Use This Catalog" first for correct use of compressors and pumps.

General Conditions

Ambient Temperature: 0 ~ 40°C  
Ambient Humidity: 30 ~ 85%  
Fluid: Air

Applications

Medical equipment, analyzers, etc.

Heavy duty rubber feet available on request.  
To prevent drop damage when located within portable devices.



Sketch Drawing and Mounting Dimensions Diagram (mm)

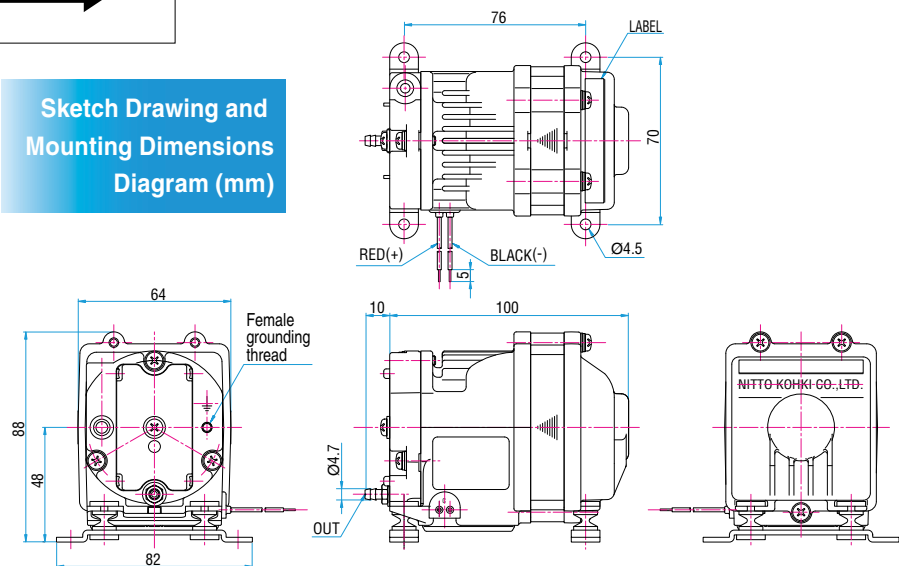

COMPRESSOR

# LINEAR Piston DC



MOTOR FREE  
PISTON SYSTEM



# DAH110-Y1 (24 V DC)

**Airflow & Electric Current**

**Specifications**

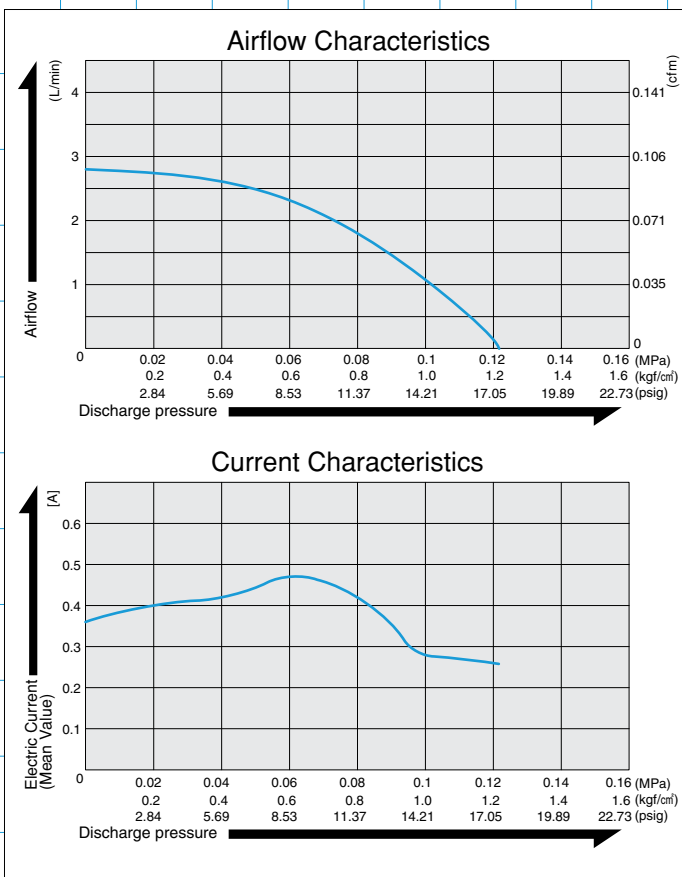

	(SI)	(EURO)	(U.S.A.)
Rated Pressure	0.1 MPa {1.0 kgf/cm <sup>2</sup> }	1.0 bar	14.2 psig
Rated Airflow	1.0 L/min <sup>※1</sup>		0.035 cfm
Rated Voltage	24 V DC		
Maximum Pressure	0.12 MPa {1.2 kgf/cm <sup>2</sup> }	1.2 bar	17.1 psig
Current (Mean Value)	0.27A		
Life Expectancy	5,000 hours ( MTTF )		
Outlet	4.7 mm O.D. hose barb		
Duty Cycle	Continuous		
Coil Insulation Class	A or its equivalent		
Mounting Dimensions	76 mm(L) x 70 mm(W)	3"(L) x 2-3/4"(W)	
Gross Weight	0.91 kg	2.01 Lbs.	
Leadwire Length	300 mm	11-13/16"	

※1: Air displacement at rated pressure.  
Please read the page of "How to Use This Catalog" first for correct use of compressors and pumps.

**General Conditions**

Ambient Temperature: 0 ~ 40°C  
Ambient Humidity: 30 ~ 85%  
Fluid: Air

**Applications**

Medical equipment, analyzers, etc.

Heavy duty rubber feet available on request.  
To prevent drop damage when located within portable devices.



**Sketch Drawing and Mounting Dimensions Diagram (mm)**

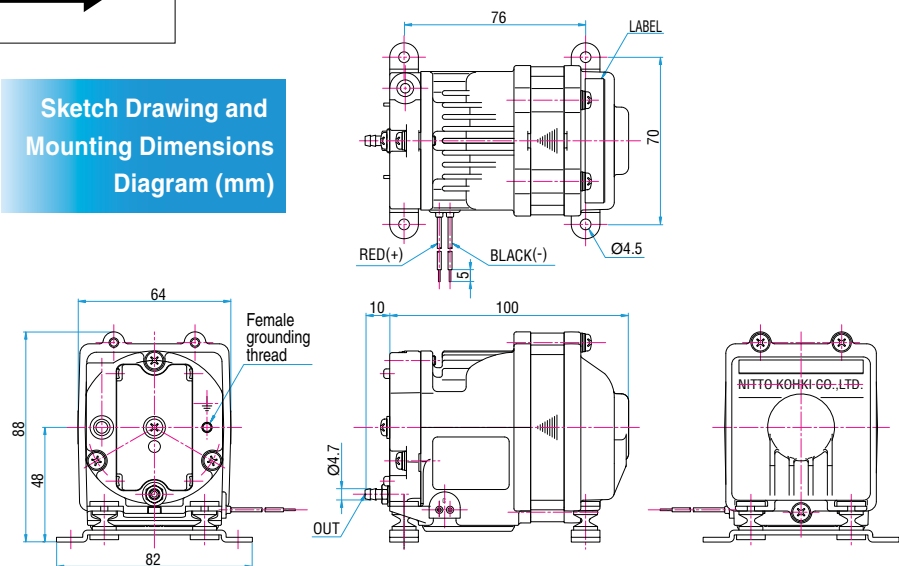







VACUUM PUMP

# DC LINEAR

## Piston Vacuum Pump

DVH130-X1  
P17

DVH130-Y1  
P18

DVH145-X1  
P19

DVH145-Y1  
P20

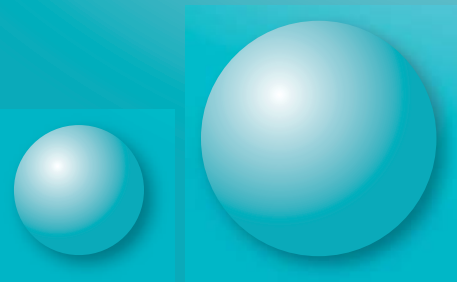

VACUUM PUMP

# LINEAR Piston DC



MOTOR FREE  
PISTON SYSTEM



# DVH130-X1 (12 V DC)

Airflow & Electric Current

Specifications

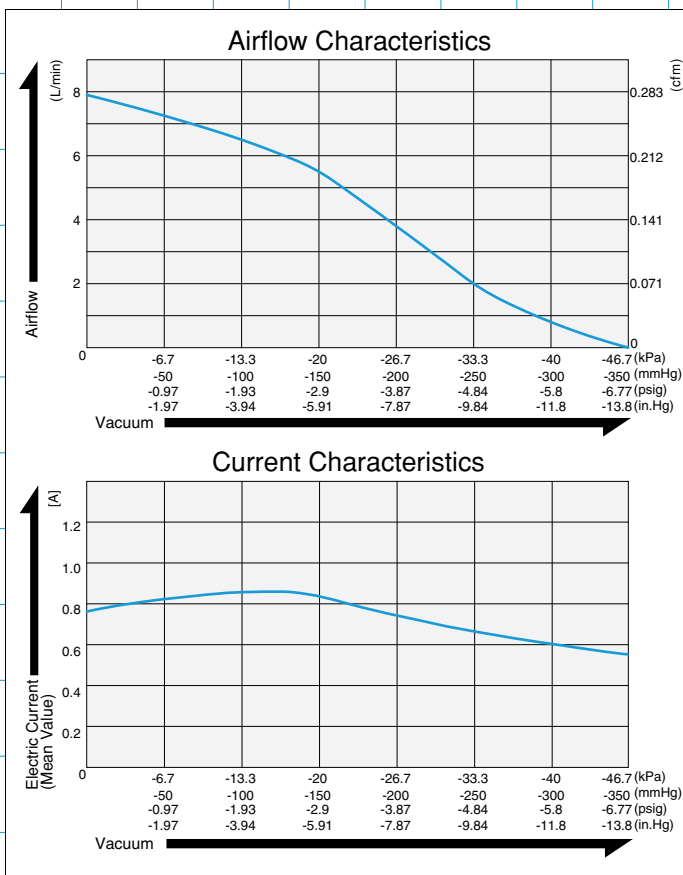

	(SI)	(EURO)	(U.S.A.)
Attainable Vacuum	-40 kPa (-300 mmHg)	-400 mbar	-11.8 in.Hg
Free Air Displacement	7 L/min <sup>※1</sup>		0.247 cfm
Rated Voltage	12 V DC		
Current (Mean Value)	0.86A		
Life Expectancy	10,000 hours		
Inlet	6 mm O.D. hose barb		
Outlet	6 mm O.D. hose barb		
Duty Cycle	Continuous		
Coil Insulation Class	A or its equivalent		
Mounting Dimensions	76 mm(L) x 70 mm(W)	3"(L) x 2-3/4"(W)	
Gross Weight	0.91 kg	2.01 Lbs.	
Leadwire Length	300 mm	11-13/16"	

※1: Air displacement at no-load operation.  
Please read the page of "How to Use This Catalog" first for correct use of compressors and pumps.

General Conditions

Ambient Temperature: 0 ~ 40°C  
Ambient Humidity: 30 ~ 85%  
Fluid: Air

Applications

Medical equipment, analyzers, etc.

Heavy duty rubber feet available on request. To prevent drop damage when located within portable devices.



Sketch Drawing and Mounting Dimensions Diagram (mm)

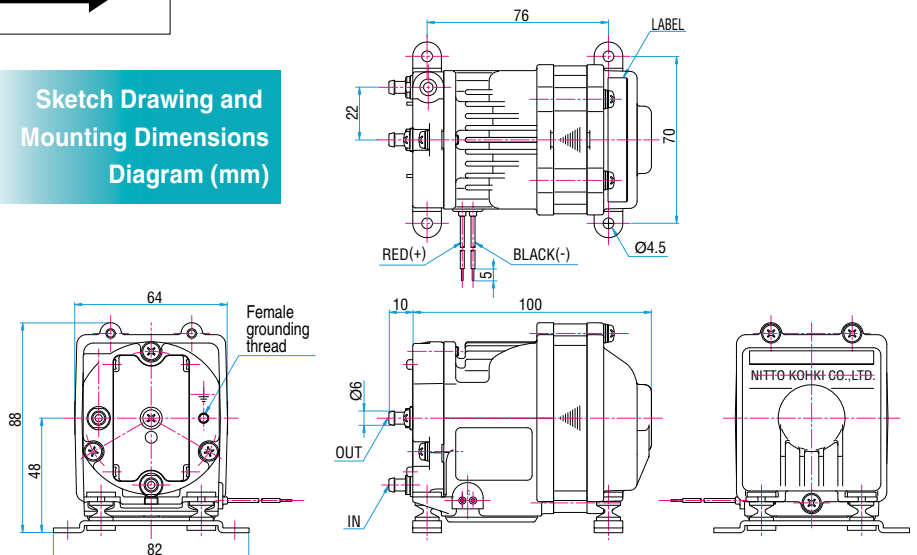

VACUUM PUMP

# LINEAR Piston DC



MOTOR FREE  
PISTON SYSTEM



# DVH130-Y1 (24 V DC)

## Airflow & Electric Current

## Specifications

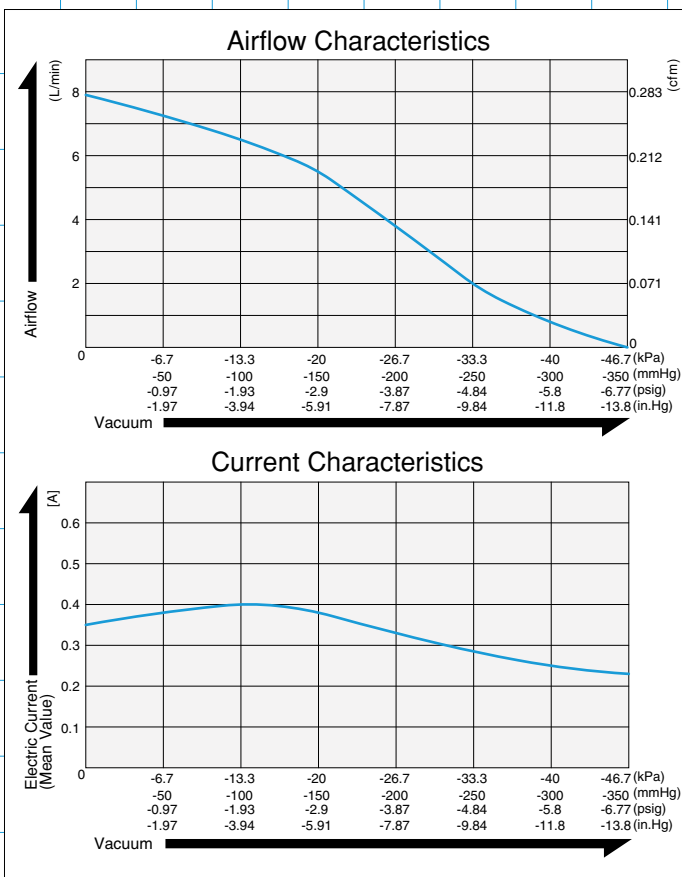

	(SI)	(EURO)	(U.S.A.)
Attainable Vacuum	-40 kPa (-300 mmHg)	-400 mbar	-11.8 in.Hg
Free Air Displacement	7 L/min <sup>※1</sup>		0.247 cfm
Rated Voltage	24 V DC		
Current (Mean Value)	0.41A		
Life Expectancy	10,000 hours		
Inlet	6 mm O.D. hose barb		
Outlet	6 mm O.D. hose barb		
Duty Cycle	Continuous		
Coil Insulation Class	A or its equivalent		
Mounting Dimensions	76 mm(L) x 70 mm(W)	3"(L) x 2-3/4"(W)	
Gross Weight	0.91 kg	2.01 Lbs.	
Leadwire Length	300 mm	11-13/16"	

※1: Air displacement at no-load operation.  
Please read the page of "How to Use This Catalog" first for correct use of compressors and pumps.

## General Conditions

Ambient Temperature: 0 ~ 40°C  
Ambient Humidity: 30 ~ 85%  
Fluid: Air

## Applications

Medical equipment, analyzers, etc.

Heavy duty rubber feet available on request.  
To prevent drop damage when located within portable devices.



## Sketch Drawing and Mounting Dimensions Diagram (mm)

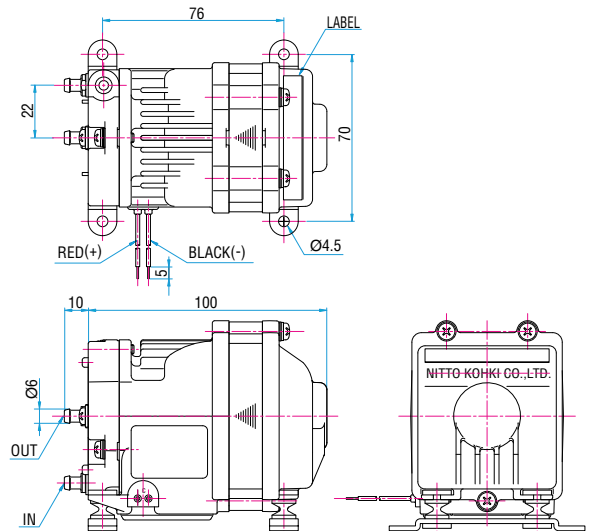
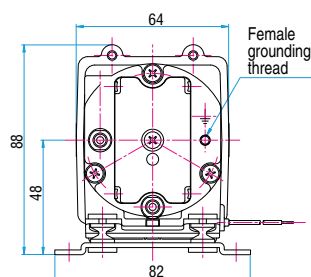

VACUUM PUMP

# LINEAR Piston DC



MOTOR FREE  
PISTON SYSTEM



# DVH145-x1 (12 V DC)

Airflow & Electric Current

Specifications

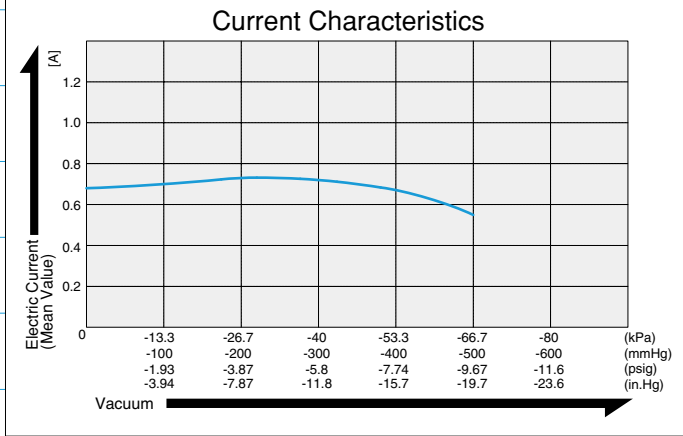
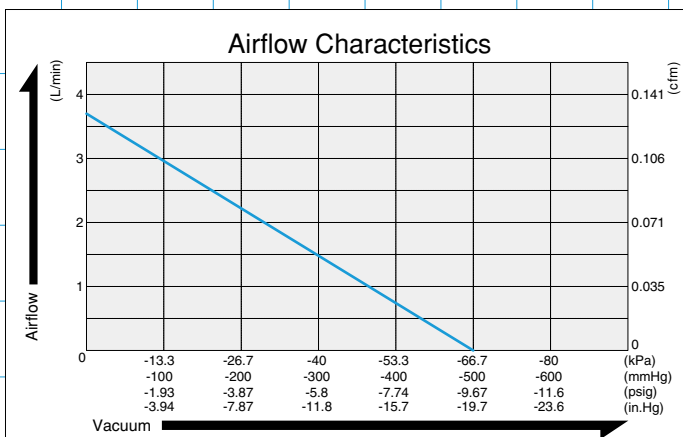

	(SI)	(EURO)	(U.S.A.)
Attainable Vacuum	-60 kPa (-450 mmHg)	-600 mbar	-17.7 in.Hg
Free Air Displacement	3 L/min *1		0.106 cfm
Rated Voltage	12 V DC		
Current (Mean Value)	0.73 A		
Life Expectancy	10,000 hours		
Inlet	6 mm O.D. hose barb		
Outlet	6 mm O.D. hose barb		
Duty Cycle	Continuous		
Coil Insulation Class	A or its equivalent		
Mounting Dimensions	76 mm(L) x 70 mm(W)	3"(L) x 2-3/4"(W)	
Gross Weight	0.91 kg	2.01 Lbs.	
Leadwire Length	300 mm	11-13/16"	

\*1: Air displacement at no-load operation.  
Please read the page of "How to Use This Catalog" first for correct use of compressors and pumps.

General Conditions

Ambient Temperature: 0 ~ 40°C  
Ambient Humidity: 30 ~ 85%  
Fluid: Air

Applications

Medical equipment, analyzers, etc.

Heavy duty rubber feet available on request. To prevent drop damage when located within portable devices.



Sketch Drawing and Mounting Dimensions Diagram (mm)

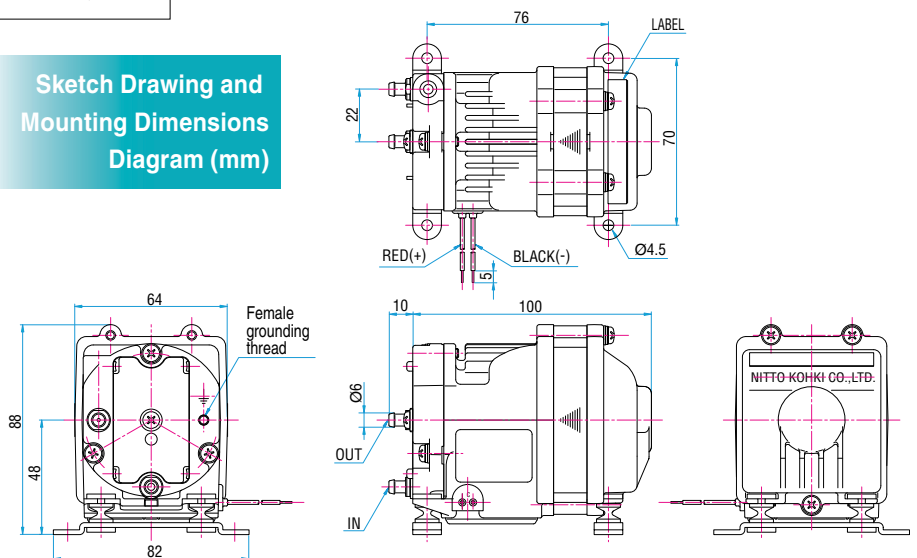

VACUUM PUMP

# LINEAR Piston DC



MOTOR FREE  
PISTON SYSTEM



# DVH145-Y1 (24 V DC)

## Airflow & Electric Current

## Specifications

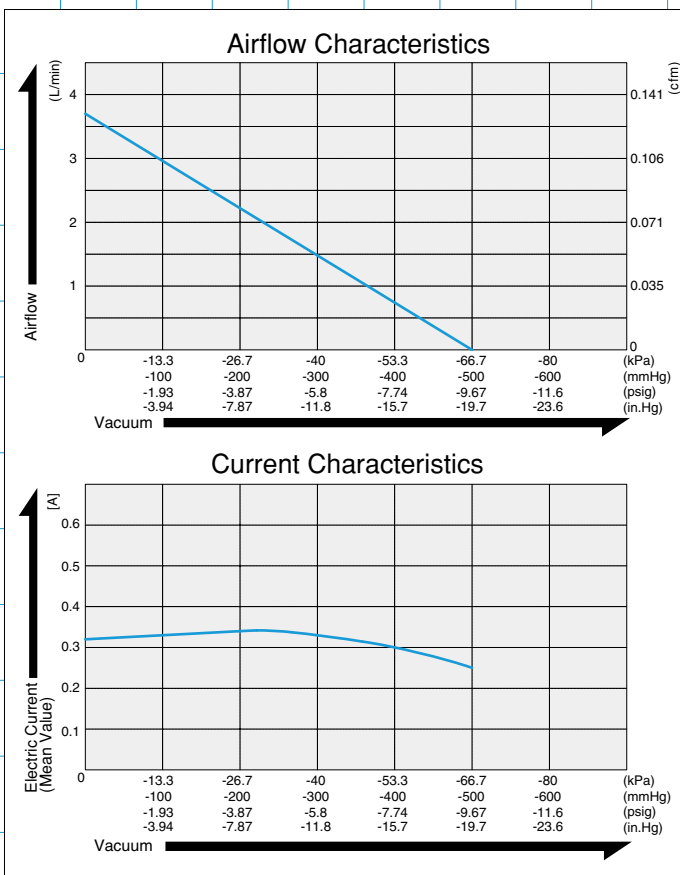

	(SI)	(EURO)	(U.S.A.)
Attainable Vacuum	-60 kPa (-450 mmHg)	-600 mbar	-17.7 in.Hg
Free Air Displacement	3 L/min *1		0.106 cfm
Rated Voltage	24 V DC		
Current (Mean Value)	0.34 A		
Life Expectancy	10,000 hours		
Inlet	6 mm O.D. hose barb		
Outlet	6 mm O.D. hose barb		
Duty Cycle	Continuous		
Coil Insulation Class	A or its equivalent		
Mounting Dimensions	76 mm(L) x 70 mm(W)	3"(L) x 2-3/4"(W)	
Gross Weight	0.91 kg	2.01 Lbs.	
Leadwire Length	300 mm	11-13/16"	

\*1: Air displacement at no-load operation.  
Please read the page of "How to Use This Catalog" first for correct use of compressors and pumps.

## General Conditions

Ambient Temperature: 0 ~ 40°C  
Ambient Humidity: 30 ~ 85%  
Fluid: Air

## Applications

Medical equipment, analyzers, etc.

Heavy duty rubber feet available on request. To prevent drop damage when located within portable devices.



## Sketch Drawing and Mounting Dimensions Diagram (mm)

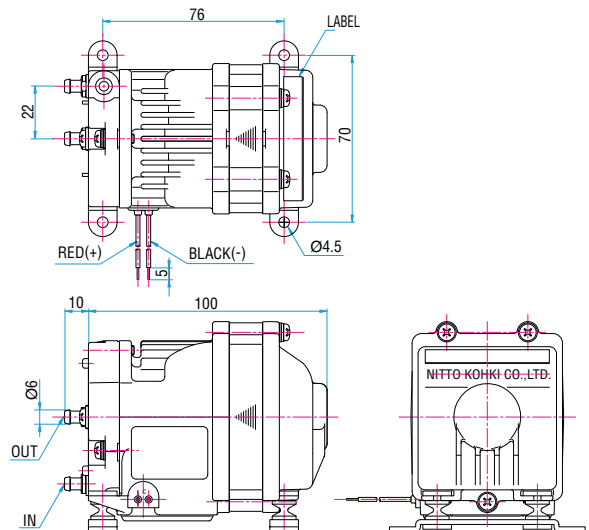
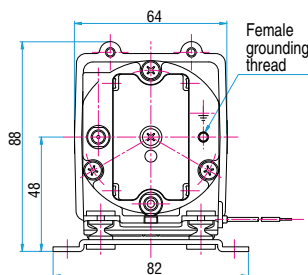





# AIR COMPRESSOR

# AC Low Pressure Series

# AC LINEAR

## Piston Compressor

AC0102  
P23

AC 0201A  
P24

AC0301A  
P25

AC0401A  
P26

AC0602  
P27

AC0901  
P28

AC0902  
P29

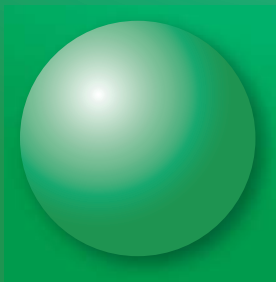

**COMPRESSOR**

# LINEAR

# Ac0102



**MOTOR FREE  
PISTON SYSTEM**



**Airflow & Power Consumption**

**Specifications**

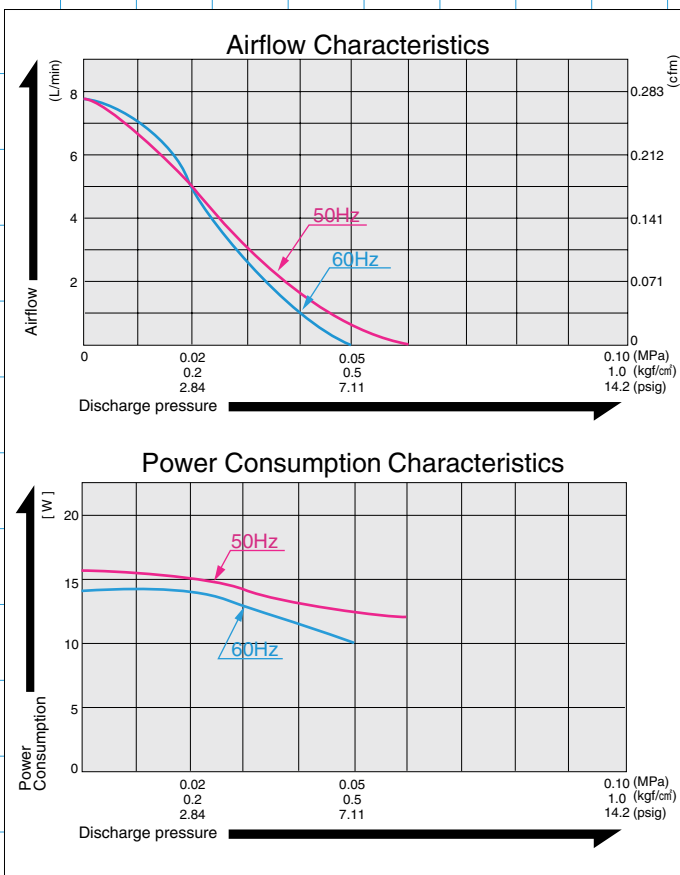

	(SI)	(EURO)	(U.S.A.)
Rated Pressure	0.02 MPa (0.2 kgf/cm <sup>2</sup> )	0.2 bar	2.84 psig
Rated Airflow	5 L/min		0.177 cfm
Rated Voltage	115 V AC or 230 V AC		
Maximum Pressure	0.04 MPa (0.4 kgf/cm <sup>2</sup> )	0.4 bar	5.69 psig
Power Consumption	14 W or 15 W		
Rated Frequency	60 Hz or 50 Hz		
Life Expectancy	3,000 hours		
Outlet	6 mm O.D. hose nipple		
Duty Cycle	Continuous		
Coil Insulation Class	E or its equivalent (JETL) and B for UL		
Mounting Dimensions	48 (L) x 62 (W) mm	1-7/8" (L) x 2-7/16" (W)	
Gross Weight	0.7 kg		1.54 Lbs.
Leadwire Length	200 mm		7-7/8"

Please read the page of "How to Use This Catalog" first for correct use of compressors and pumps.

**Application Examples**

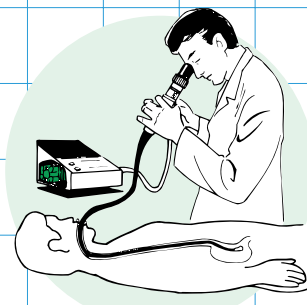

**Endoscope**

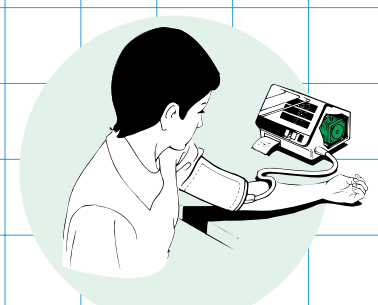

**Blood Pressure Tester**

**Sketch Drawing and Mounting Dimensions Diagram (mm)**

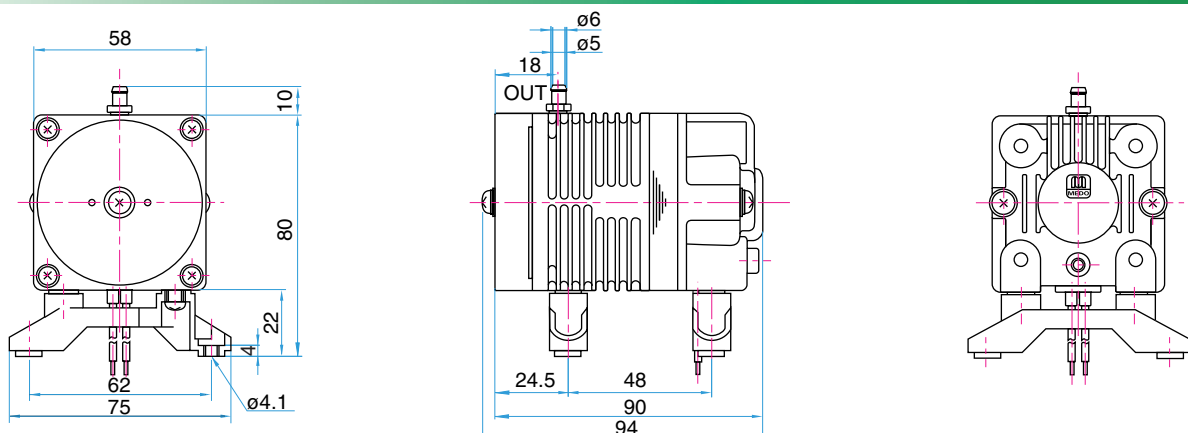



**COMPRESSOR**

# LINEAR

# Ac0201A



**MOTOR FREE  
PISTON SYSTEM**



**Airflow & Power Consumption**

**Specifications**

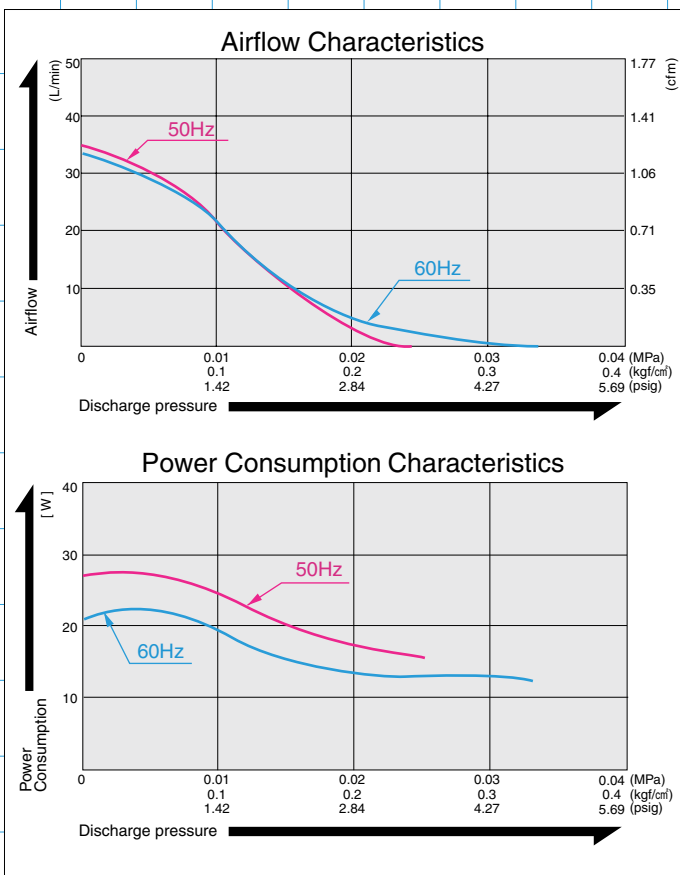

	(SI)	(EURO)	(U.S.A.)
Rated Pressure	0.01 MPa (0.1 kgf/cm <sup>2</sup> )	0.1 bar	1.42 psig
Rated Airflow	20 L/min		0.71 cfm
Rated Voltage	115 V AC or 230 V AC		
Maximum Pressure	0.02 MPa (0.2 kgf/cm <sup>2</sup> )	0.2 bar	2.84 psig
Power Consumption	19 W or 23 W		
Rated Frequency	60 Hz or 50 Hz		
Life Expectancy	6,000 hours		
Outlet	ISO Rc 1/4 (female threaded)		
Duty Cycle	Continuous		
Coil Insulation Class	E or its equivalent (JETL) and B for UL		
Mounting Dimensions	73 (L) x 88 (W) mm	2-7/8" (L) x 3-15/32" (W)	
Gross Weight	1.5 kg	3.3 Lbs.	
Leadwire Length	200 mm	7-7/8"	

Please read the page of "How to Use This Catalog" first for correct use of compressors and pumps.

**Application Examples**

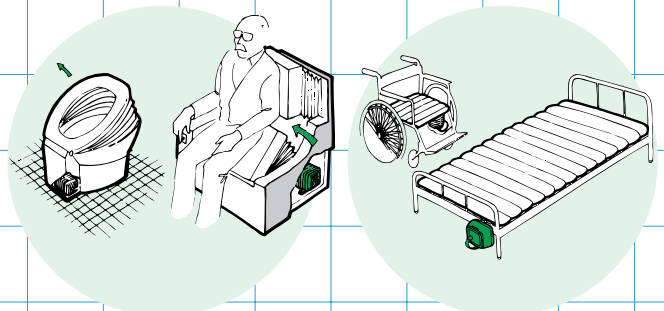

**Seat Lifter**

**Bed Sore Prevention Mattress**

**Sketch Drawing and Mounting Dimensions Diagram (mm)**

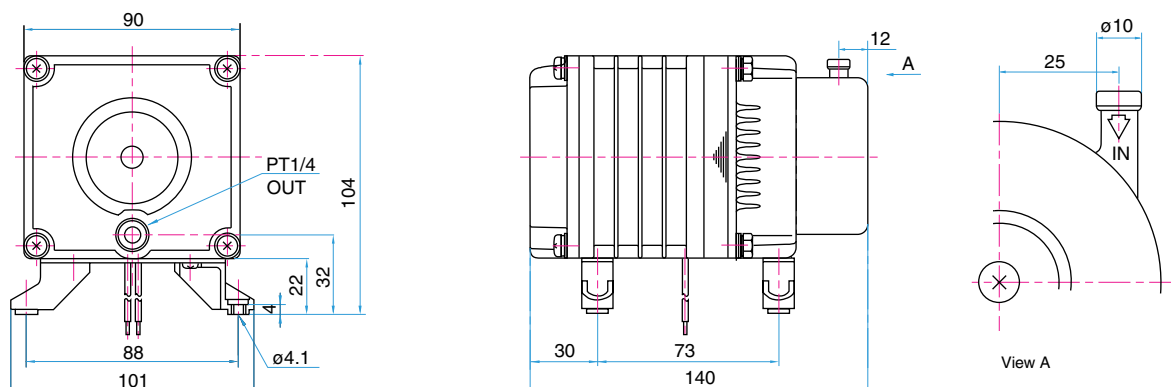

COMPRESSOR

# LINEAR

# Ac0301A



MOTOR FREE  
PISTON SYSTEM



Airflow & Power Consumption

Specifications

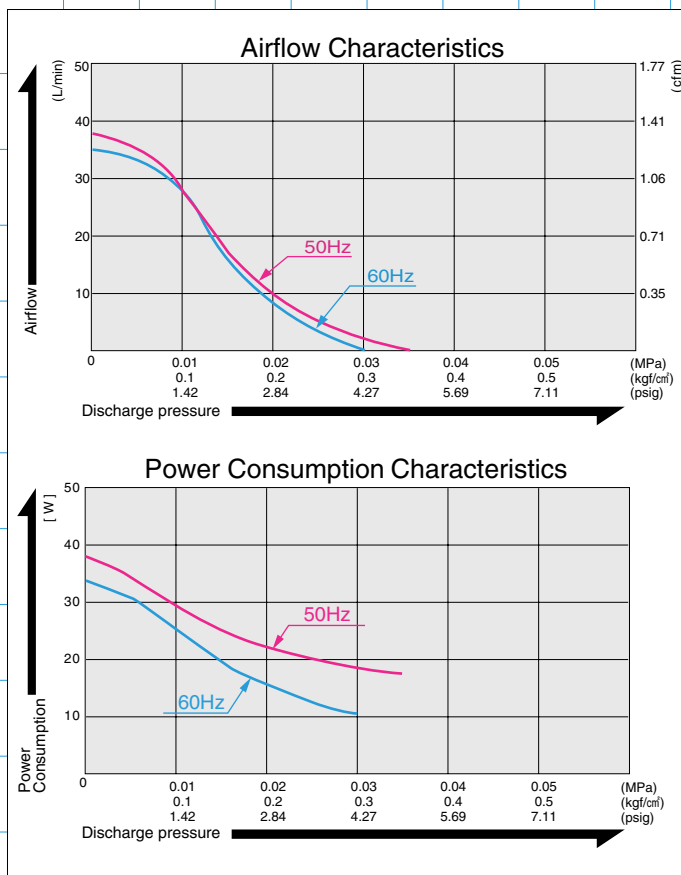

	(SI)	(EURO)	(U.S.A.)
Rated Pressure	0.01 MPa (0.1 kgf/cm <sup>2</sup> )	0.1 bar	1.42 psig
Rated Airflow	28 L/min		0.99 cfm
Rated Voltage	115 V AC or 230 V AC		
Maximum Pressure	0.03 MPa (0.3 kgf/cm <sup>2</sup> )	0.3 bar	4.27 psig
Power Consumption	25 W or 29 W		
Rated Frequency	60 Hz or 50 Hz		
Life Expectancy	10,000 hours		
Outlet	ISO Rc 1/4 (female threaded)		
Duty Cycle	Continuous		
Coil Insulation Class	E or its equivalent (JETL) or B for UL		
Mounting Dimensions	68 (L) x 84 (W) mm	2-11/16" (L) x 3-5/16" (W)	
Gross Weight	1.9 kg	4.2 Lbs.	
Leadwire Length	200 mm	7-7/8"	

Please read the page of "How to Use This Catalog" first for correct use of compressors and pumps.

Application Examples

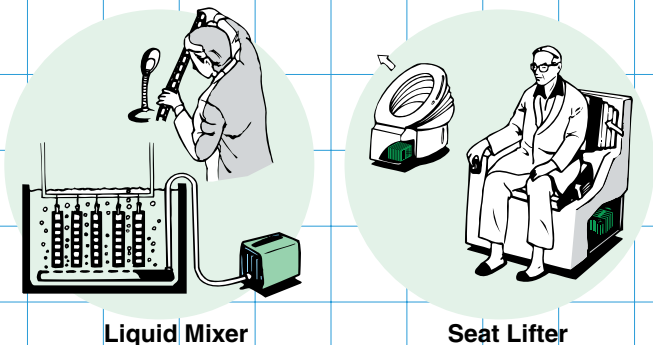

Liquid Mixer

Seat Lifter

Sketch Drawing and Mounting Dimensions Diagram (mm)

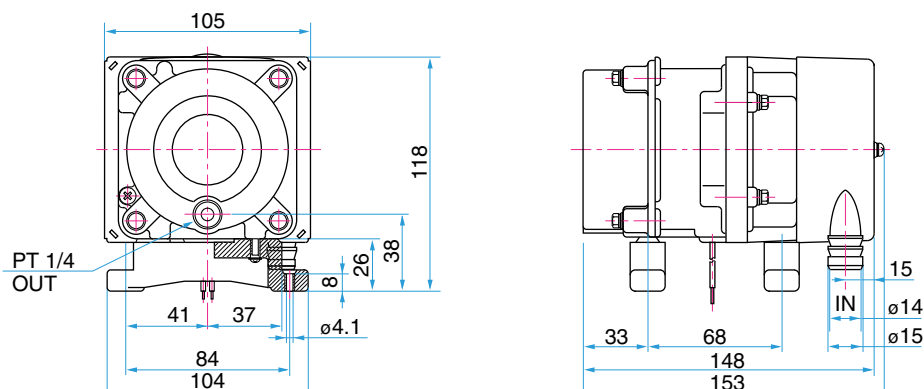

COMPRESSOR

# LINEAR

# Ac0401A



MOTOR FREE  
PISTON SYSTEM



Airflow & Power Consumption

Specifications

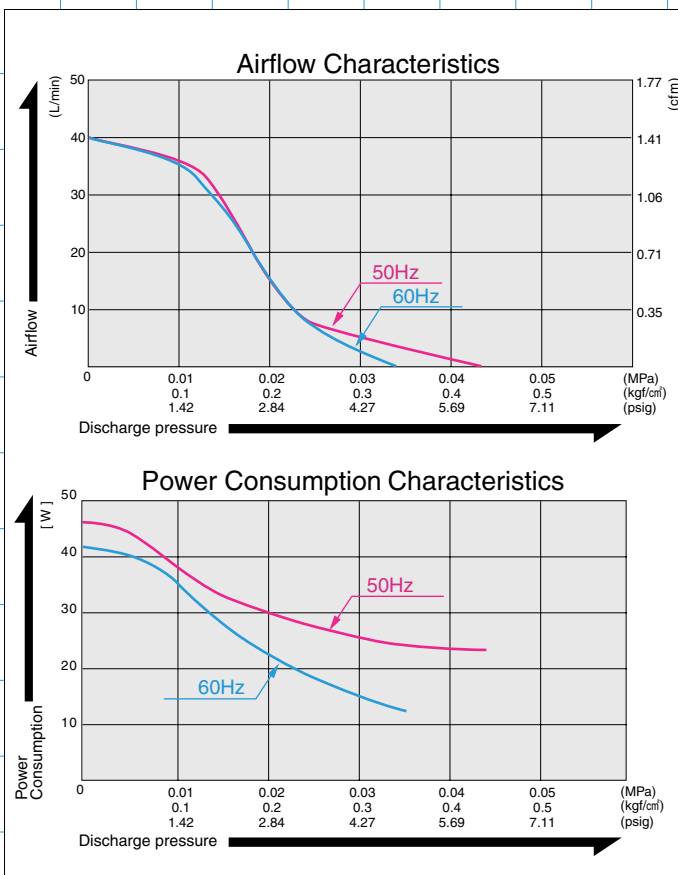

	(SI)	(EURO)	(U.S.A.)
Rated Pressure	0.01 MPa (0.1 kgf/cm <sup>2</sup> )	0.1 bar	1.42 psig
Rated Airflow	35 L/min		1.24 cfm
Rated Voltage	120 V AC or 230 V AC		
Maximum Pressure	0.035 MPa (0.35 kgf/cm <sup>2</sup> )	0.35 bar	4.98 psig
Power Consumption	35 W or 38 W		
Rated Frequency	60 Hz or 50 Hz		
Life Expectancy	10,000 hours		
Outlet	ISO Rc 1/4 (female threaded)		
Duty Cycle	Continuous		
Coil Insulation Class	E or its equivalent (JETL) or B for UL		
Mounting Dimensions	68 (L) x 84 (W) mm	2-11/16" (L) x 3-5/16" (W)	
Gross Weight	1.9 kg	4.2 Lbs.	
Leadwire Length	200 mm	7-7/8"	

Please read the page of "How to Use This Catalog" first for correct use of compressors and pumps.

Application Examples

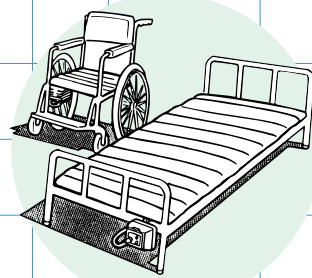

Bed Sore Prevention Mattress

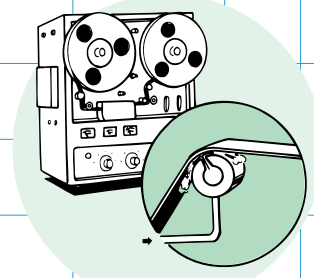

Air Bearing

Sketch Drawing and Mounting Dimensions Diagram (mm)

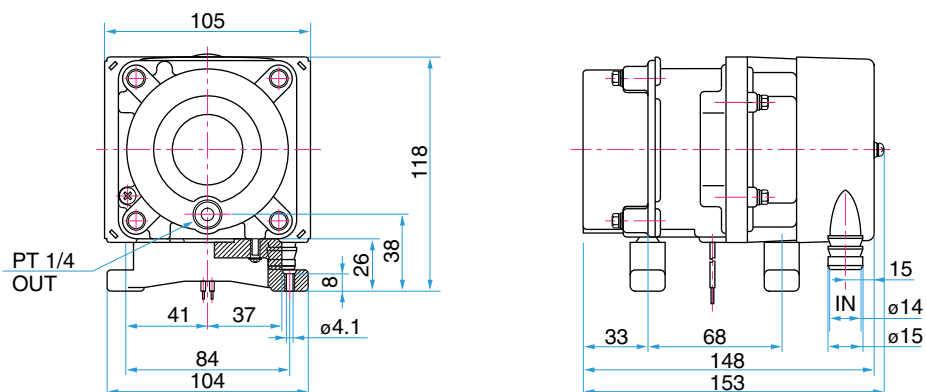



# COMPRESSOR

# LINEAR Ac0901



**MOTOR FREE  
PISTON SYSTEM**



## Airflow & Power Consumption

## Specifications

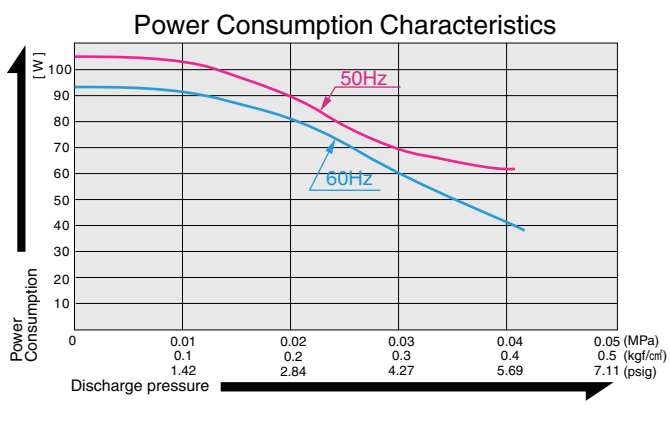
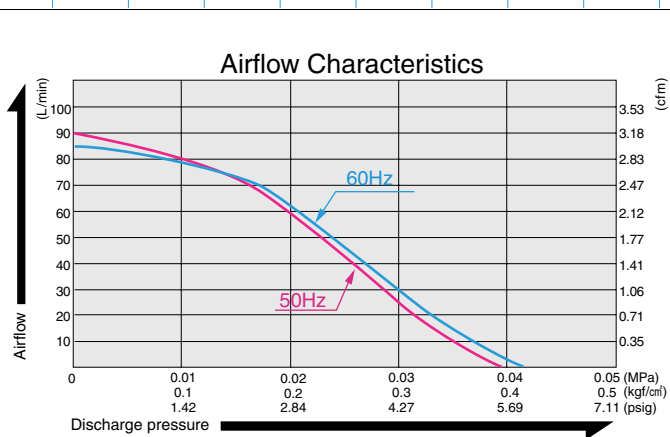

	(SI)	(EURO)	(U.S.A.)
Rated Pressure	0.01 MPa (0.1 kgf/cm <sup>2</sup> )	0.1 bar	1.42 psig
Rated Airflow	80 L/min		2.83 cfm
Rated Voltage	115 V AC or 230 V AC		
Maximum Pressure	0.04 MPa (0.4 kgf/cm <sup>2</sup> )	0.4 bar	5.69 psig
Power Consumption	88 W or 99 W		
Rated Frequency	60 Hz or 50 Hz		
Life Expectancy	10,000 hours		
Outlet	ISO Rc 3/8 (female threaded)		
Duty Cycle	Continuous		
Coil Insulation Class	E or its equivalent (JETL) or B for UL		
Mounting Dimensions	102 (L) x 130 (W) mm	4"(L) x 5-1/8"(W)	
Gross Weight	4.9 kg	10.8 Lbs.	
Leadwire Length	300 mm	11-13/16" for 115V	

Please read the page of "How to Use This Catalog" first for correct use of compressors and pumps.

## Application Examples

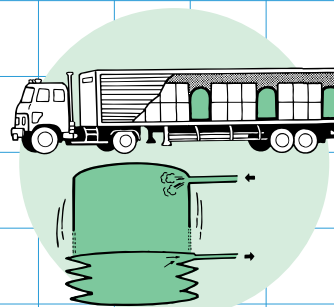

**Pneumatic Jack**

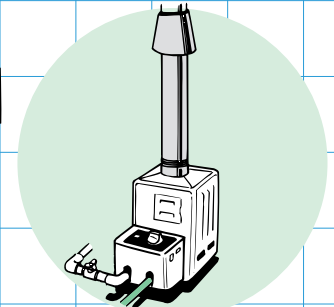

**Gas Burner Booster**

## Sketch Drawing and Mounting Dimensions Diagram (mm)

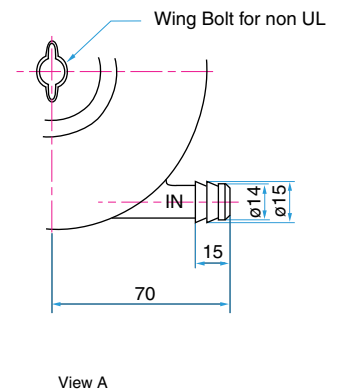
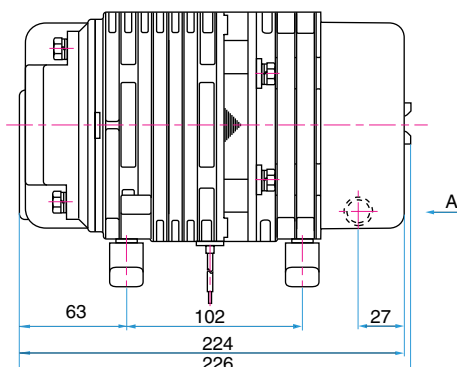
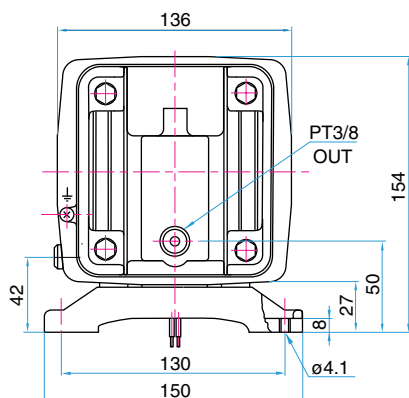

COMPRESSOR

# LINEAR

# Ac0902

   
**MOTOR FREE  
 PISTON SYSTEM**



**Airflow & Power Consumption**

**Specifications**

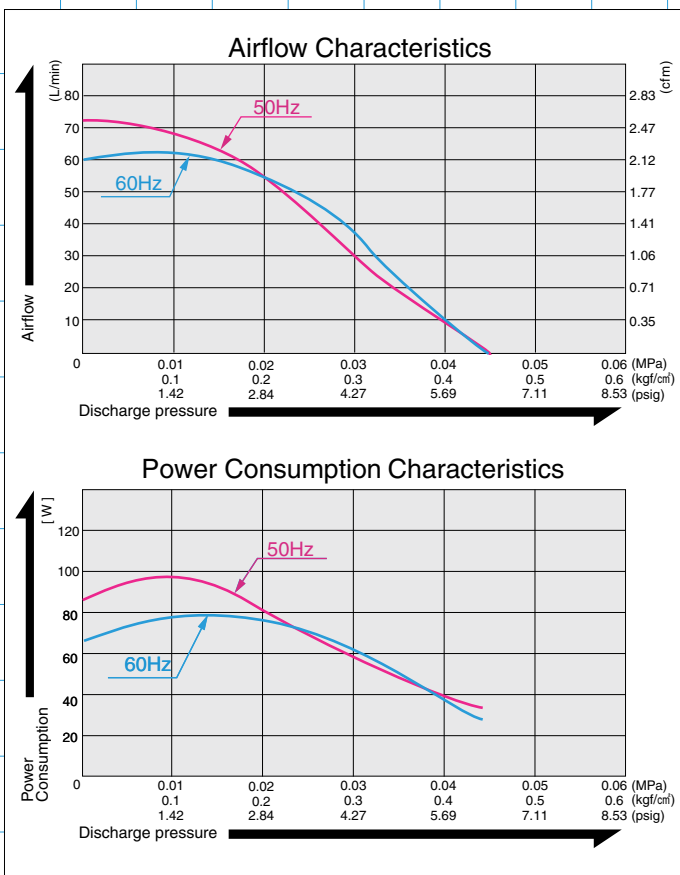

	(SI)	(EURO)	(U.S.A.)
Rated Pressure	0.02 MPa (0.2 kgf/cm <sup>2</sup> )	0.2 bar	2.84 psig
Rated Airflow	55 L/min		1.94 cfm
Rated Voltage	115 V AC or 230 V AC		
Maximum Pressure	0.045 MPa (0.45 kgf/cm <sup>2</sup> )	0.45 bar	6.4 psig
Power Consumption	75 W or 85 W		
Rated Frequency	60 Hz or 50 Hz		
Life Expectancy	10,000 hours		
Outlet	ISO Rc 3/8 (female threaded)		
Duty Cycle	Continuous		
Coil Insulation Class	E or its equivalent (JETL) and B for UL		
Mounting Dimensions	102 (L) x 130 (W) mm	4"(L) x 5-1/8"(W)	
Gross Weight	4.9 kg	10.8 Lbs.	
Leadwire Length	300 mm	11-13/16" for 115V	

Please read the page of "How to Use This Catalog" first for correct use of compressors and pumps.

**Application Examples**

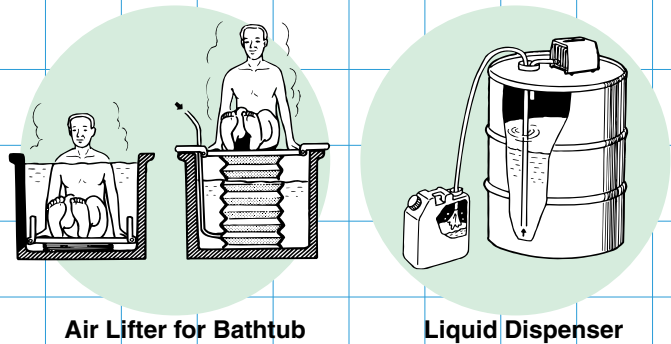

**Sketch Drawing and Mounting Dimensions Diagram (mm)**

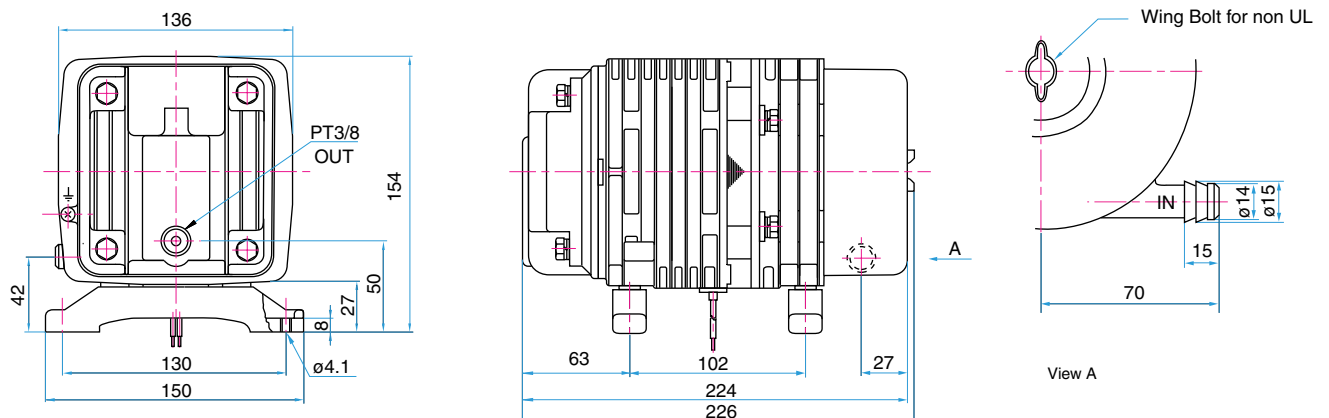



**AIR COMPRESSOR**

**AC** Intermediate  
Pressure Series  
**LINEAR**  
**Piston Compressor**

AC0105  
P31

AC 0110  
P32

AC0207  
P33

AC0410A  
P34

AC0610  
P35

AC0910  
P36

AC0920  
P37

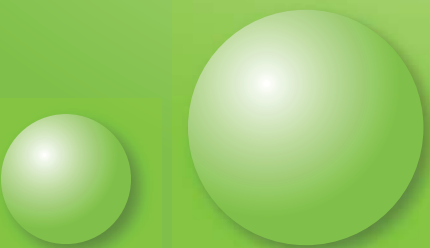

COMPRESSOR

# LINEAR

# Ac0105



MOTOR FREE  
PISTON SYSTEM



Airflow & Power Consumption

Specifications

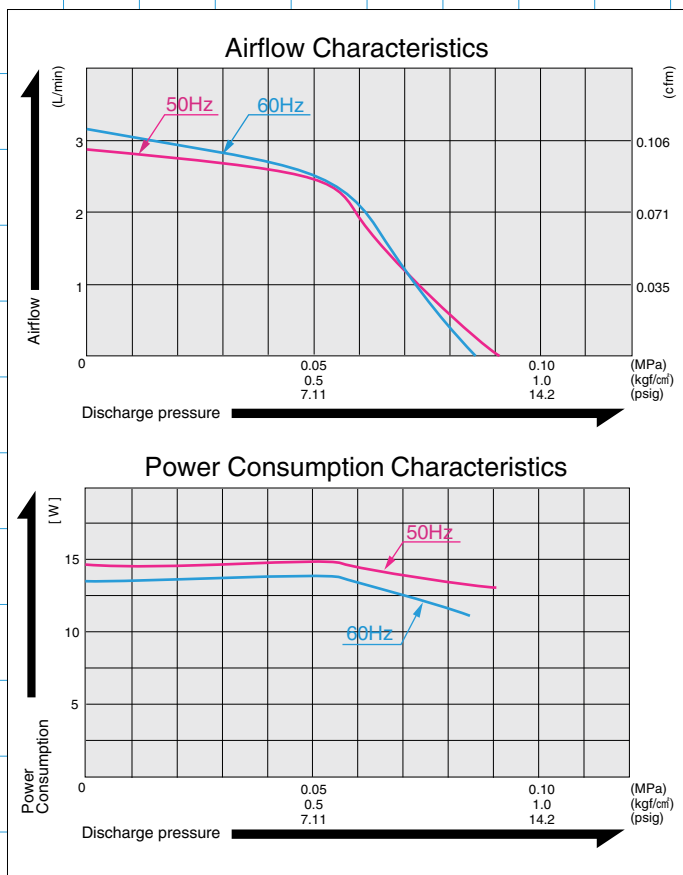

	(SI)	(EURO)	(U.S.A.)
Rated Pressure	0.05 MPa (0.5 kgf/cm <sup>2</sup> )	0.5 bar	7.1 psig
Rated Airflow	2.5 L/min		0.088 cfm
Rated Voltage	115 V AC or 230 V AC		
Maximum Pressure	0.08 MPa (0.8 kgf/cm <sup>2</sup> )	0.8 bar	11.4 psig
Power Consumption	14 W or 15 W		
Rated Frequency	60 Hz or 50 Hz		
Life Expectancy	3,000 hours		
Outlet	6 mm O.D. hose nipple		
Duty Cycle	60 minutes		
Coil Insulation Class	E or its equivalent (JETL) or B for UL		
Mounting Dimensions	48 (L) x 62 (W) mm	1-7/8" (L) x 2-7/16" (W)	
Gross Weight	0.7 kg	1.54 Lbs.	
Leadwire Length	200 mm	7-7/8"	

Please read the page of "How to Use This Catalog" first for correct use of compressors and pumps.

Application Examples

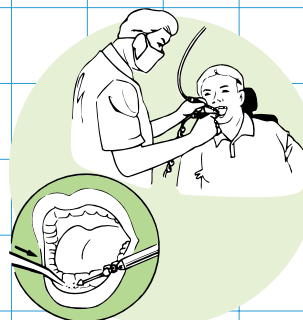

Saline Water Splasher

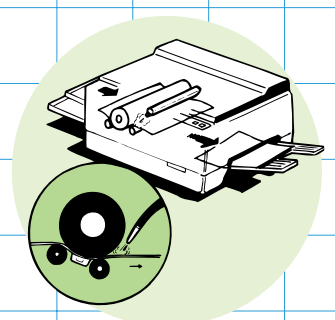

Copy Paper Separator

Sketch Drawing and Mounting Dimensions Diagram (mm)

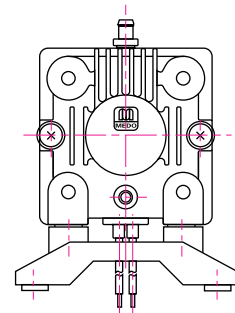
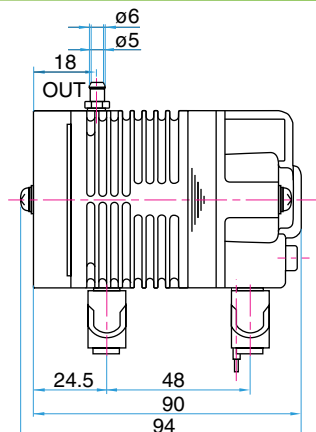
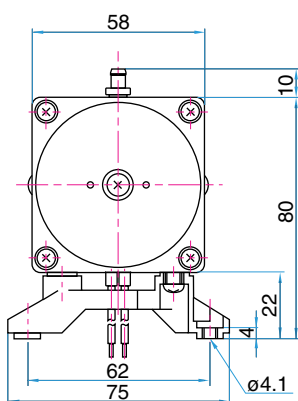



COMPRESSOR

# LINEAR

# Ac0110



MOTOR FREE  
PISTON SYSTEM



Airflow & Power Consumption

Specifications

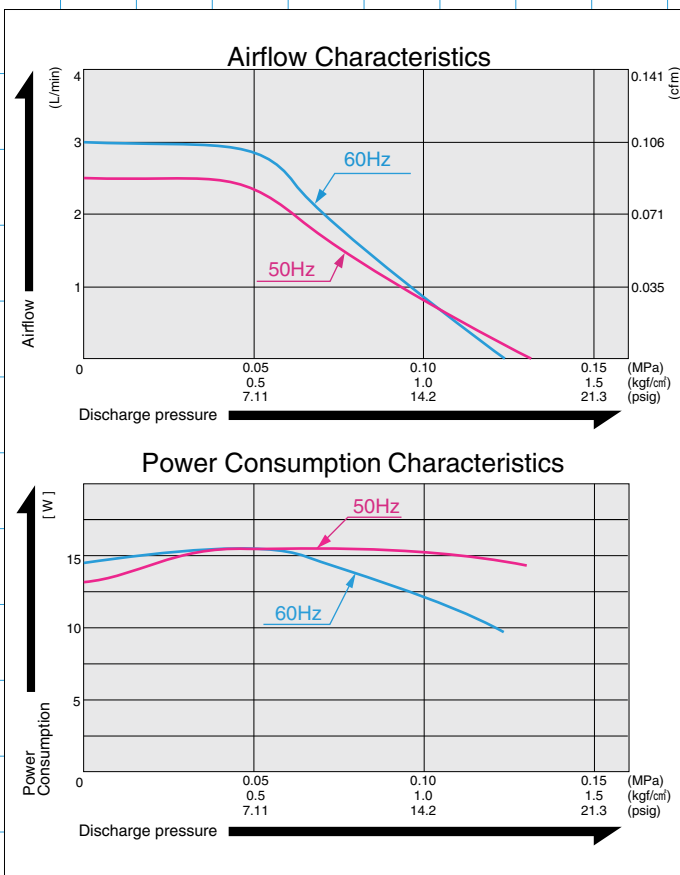

	(SI)	(EURO)	(U.S.A.)
Rated Pressure	0.1 MPa {1.0 kgf/cm <sup>2</sup> }	1.0 bar	14.2 psig
Rated Airflow	0.8 L/min		0.028 cfm
Rated Voltage	115 V AC or 230 V AC		
Maximum Pressure	0.12 MPa {1.2 kgf/cm <sup>2</sup> }	1.2 bar	17.1 psig
Power Consumption	12 W or 15 W		
Rated Frequency	60 Hz or 50 Hz		
Life Expectancy	3,000 hours		
Outlet	6 mm O.D. hose nipple		
Duty Cycle	30 minutes		
Coil Insulation Class	E or its equivalent (JETL) and B for UL		
Mounting Dimensions	48 (L) x 62 (W) mm	1-7/8" (L) x 2-7/16" (W)	
Gross Weight	0.7 kg	1.54 Lbs.	
Leadwire Length	200 mm	7-7/8"	

Please read the page of "How to Use This Catalog" first for correct use of compressors and pumps.

Application Examples

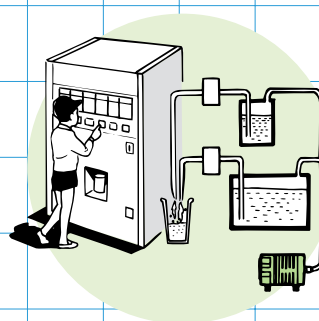

Automatic Dispenser

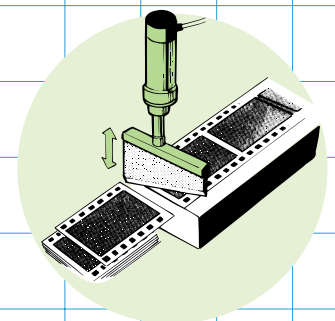

Film Cutter

Sketch Drawing and Mounting Dimensions Diagram (mm)

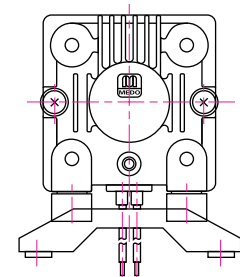
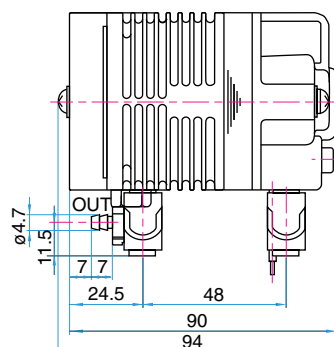
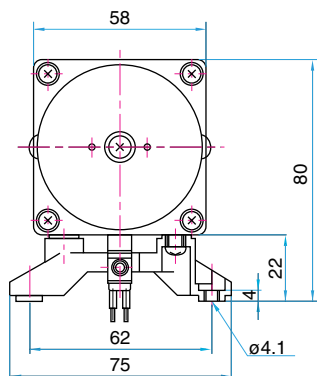

COMPRESSOR

# LINEAR

# Ac0207



MOTOR FREE  
PISTON SYSTEM



Airflow & Power Consumption

Specifications

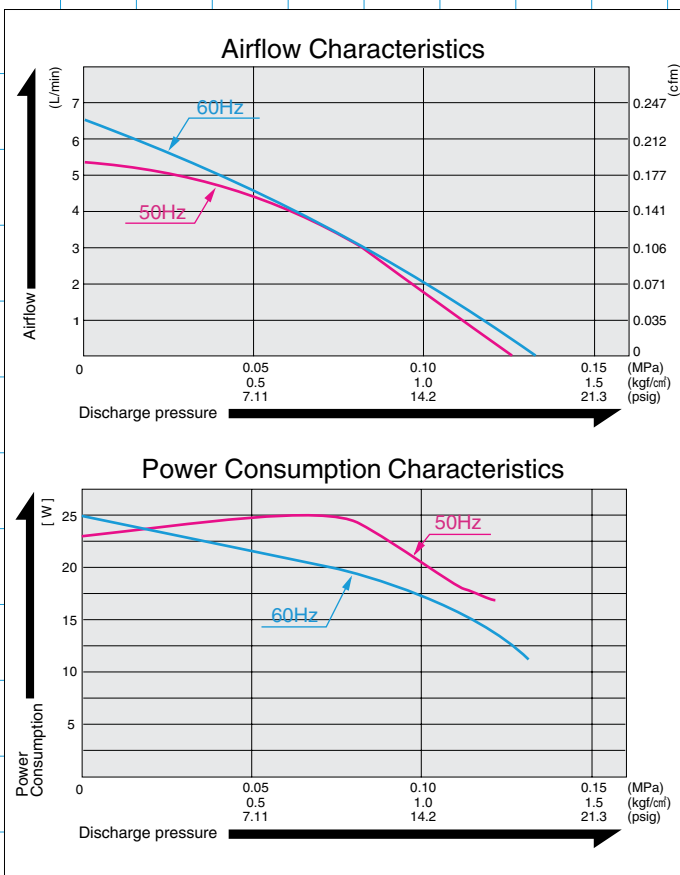

	(SI)	(EURO)	(U.S.A.)
Rated Pressure	0.07 MPa {0.7 kgf/cm <sup>2</sup> }	0.7 bar	9.96 psig
Rated Airflow	3.5 L/min		0.124 cfm
Rated Voltage	115 V AC or 230 V AC		
Maximum Pressure	0.1 MPa {1.0 kgf/cm <sup>2</sup> }	1.0 bar	14.2 psig
Power Consumption	20 W or 25 W		
Rated Frequency	60 Hz or 50 Hz		
Life Expectancy	3,000 hours		
Outlet	4.7 mm O.D. hose nipple		
Duty Cycle	Continuous		
Coil Insulation Class	E or its equivalent (JETL) or B for UL		
Mounting Dimensions	75 (L) x 88 (W) mm	2-15/16" (L) x 3-15/32" (W)	
Gross Weight	1.7 kg	3.7 Lbs.	
Leadwire Length	200 mm	7-7/8"	

Please read the page of "How to Use This Catalog" first for correct use of compressors and pumps.

Application Examples

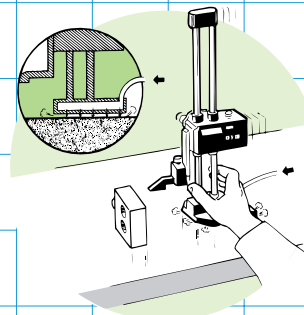

Air Bearing for Precision Machines

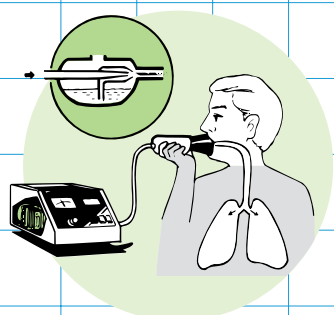

Nebulizer

Sketch Drawing and Mounting Dimensions Diagram (mm)

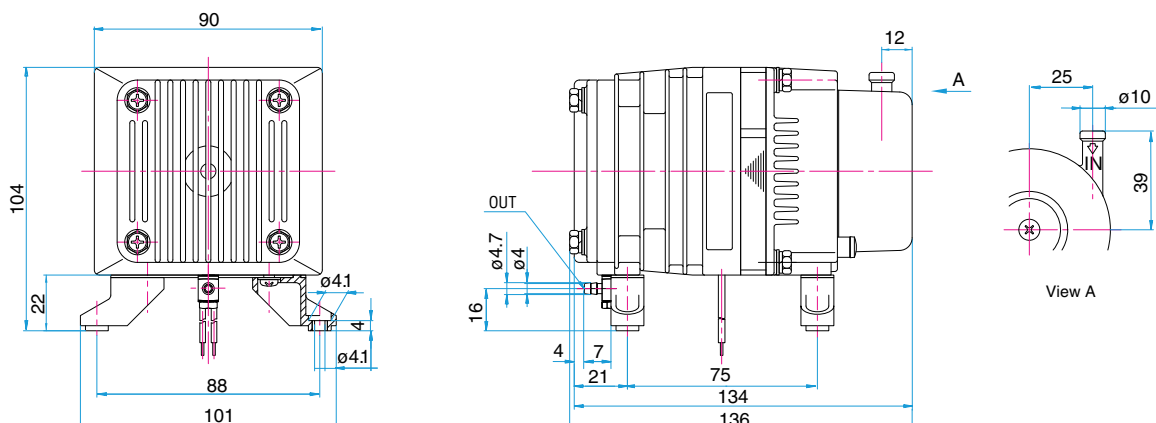

COMPRESSOR

# LINEAR

# Ac0410A



MOTOR FREE  
PISTON SYSTEM



Airflow & Power Consumption

Specifications

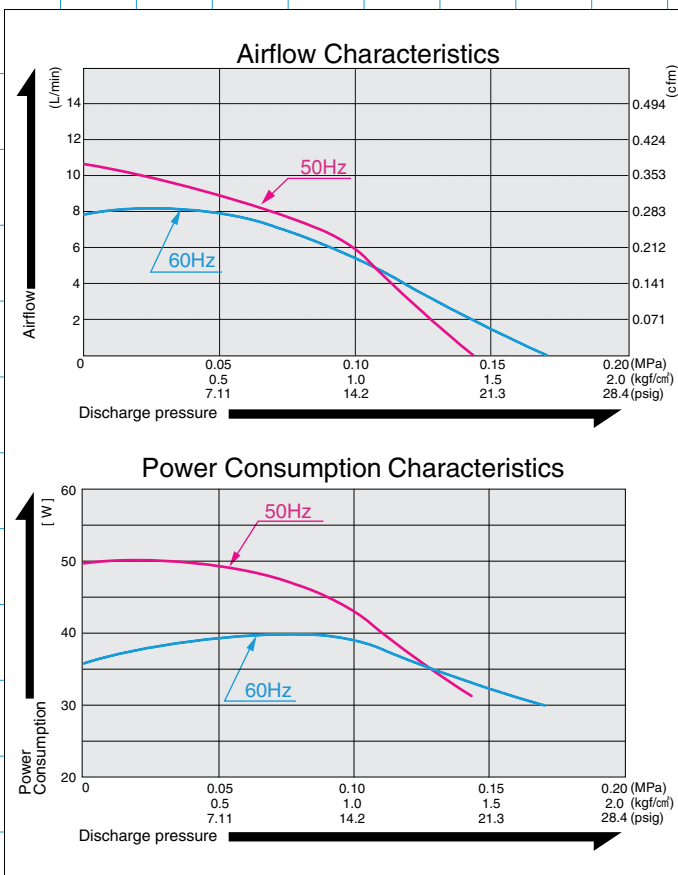

	(SI)	(EURO)	(U.S.A.)
Rated Pressure	0.1 MPa {1.0 kgf/cm <sup>2</sup> }	1.0 bar	14.2 psig
Rated Airflow	5 L/min		0.177 cfm
Rated Voltage	115 V AC or 230 V AC		
Maximum Pressure	0.13 MPa (1.3 kgf/cm <sup>2</sup> )	1.3 bar	18.5 psig
Power Consumption	39 W or 43 W		
Rated Frequency	60 Hz or 50 Hz		
Life Expectancy	3,000 hours		
Outlet	ISO Rc 1/4 (female threaded)		
Duty Cycle	Continuous		
Coil Insulation Class	E or its equivalent (JETL) or B <sup>*1</sup>		
Mounting Dimensions	68 (L) x 98 (W) mm	2-11/16" (L) x 3-7/8" (W)	
Gross Weight	2.1 kg	4.6 Lbs.	
Leadwire Length	220 mm or 200 mm	8-5/8"	

\*1: Will apply for UL.

Please read the page of "How to Use This Catalog" first for correct use of compressors and pumps.

Application Examples

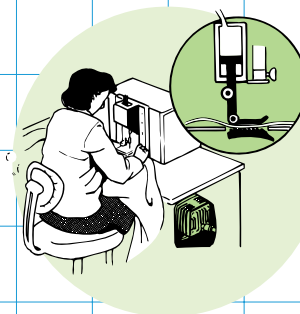

Industrial Sewing Machine



Various Aerosol Sprays

Sketch Drawing and Mounting Dimensions Diagram (mm)

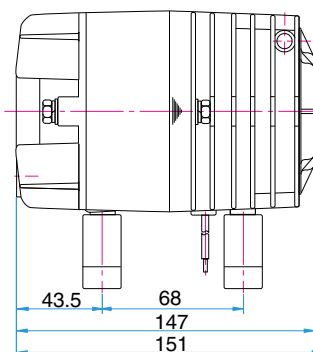
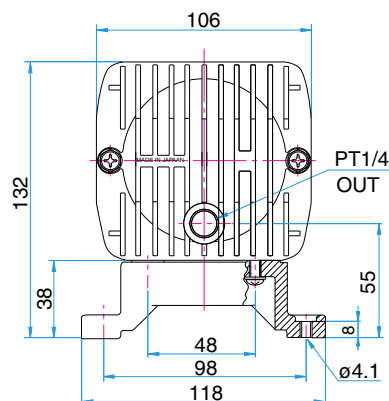

COMPRESSOR

# LINEAR



MOTOR FREE  
PISTON SYSTEM



# Ac0610A

Airflow & Power Consumption

Specifications

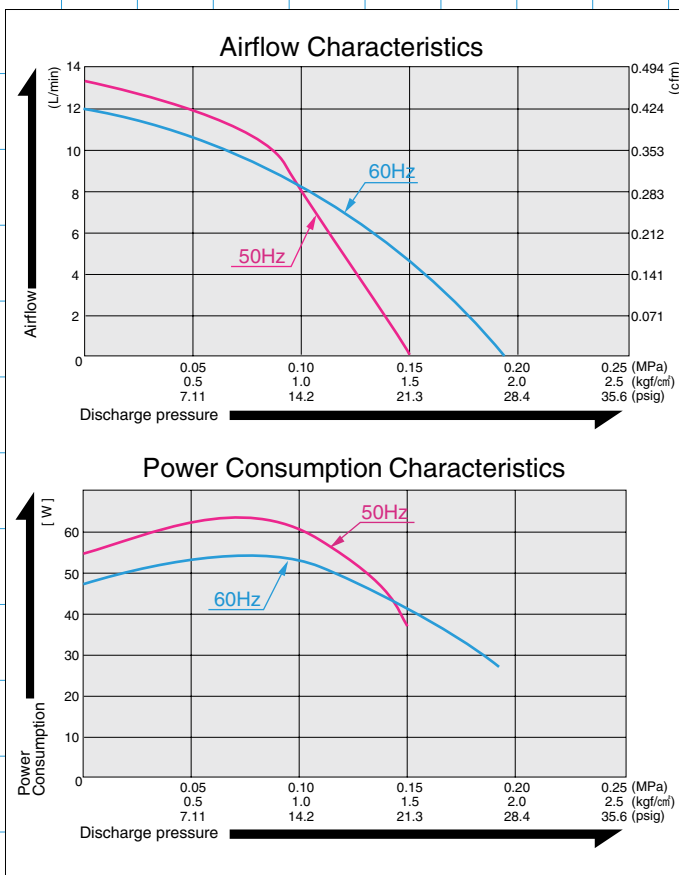

	(SI)	(EURO)	(U.S.A.)
Rated Pressure	0.1 MPa {1.0 kgf/cm <sup>2</sup> }	1.0 bar	14.2 psig
Rated Airflow	8 L/min		0.283 cfm
Rated Voltage	115 V AC or 230 V AC		
Maximum Pressure	0.15 MPa {1.5 kgf/cm <sup>2</sup> }	1.5 bar	21.3 psig
Power Consumption	52 W or 60 W		
Rated Frequency	60 Hz or 50 Hz		
Life Expectancy	10,000 hours		
Outlet	ISO Rc 1/4 (female threaded)		
Duty Cycle	Continuous		
Coil Insulation Class	F or its equivalent (JETL) and F <sup>※1</sup>		
Mounting Dimensions	68 (L) x 84 (W) mm	2-11/16" (L) x 3-5/16" (W)	
Gross Weight	3.2 kg	7.1 Lbs.	
Leadwire Length	200 mm	7-7/8"	

※1: Will apply for UL.  
Please read the page of "How to Use This Catalog" first for correct use of compressors and pumps.

Application Examples

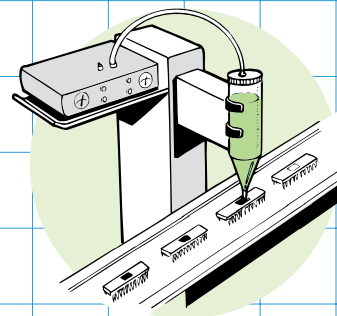

Dispenser

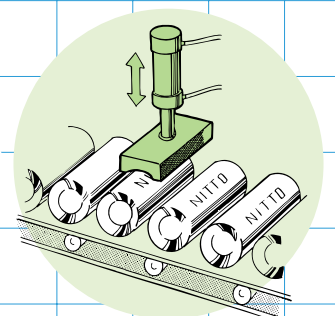

Automatic Stamper

Sketch Drawing and Mounting Dimensions Diagram (mm)

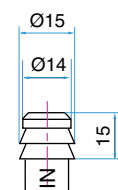
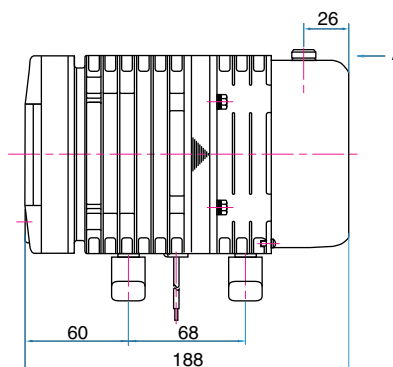
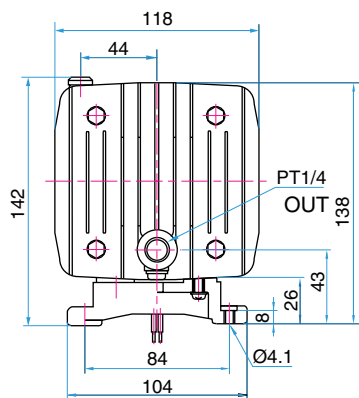

View A

COMPRESSOR

# LINEAR

# Ac0910



MOTOR FREE  
PISTON SYSTEM



Airflow & Power Consumption

Specifications

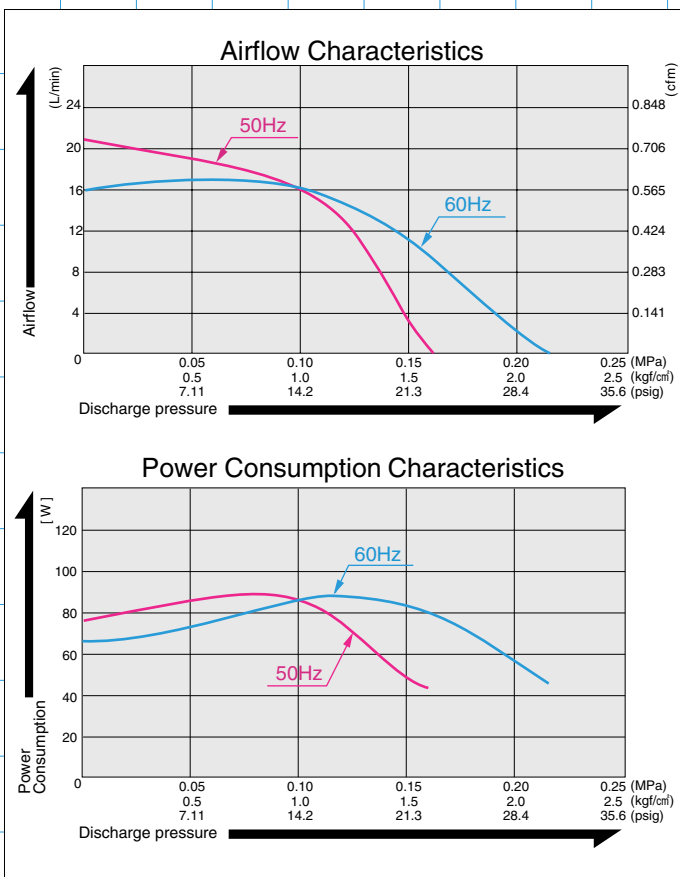

	(SI)	(EURO)	(U.S.A.)
Rated Pressure	0.1 MPa {1.0 kgf/cm <sup>2</sup> }	1.0 bar	14.2 psig
Rated Airflow	16 L/min		0.565 cfm
Rated Voltage	115 V AC or 230 V AC		
Maximum Pressure	0.15 MPa {1.5 kgf/cm <sup>2</sup> }	1.5 bar	21.3 psig
Power Consumption	85 W or 90 W		
Rated Frequency	60 Hz or 50 Hz		
Life Expectancy	3,000 hours		
Outlet	ISO Rc 1/4 (female threaded)		
Duty Cycle	Continuous		
Coil Insulation Class	E or its equivalent (JETL) and B for UL		
Mounting Dimensions	102 (L) x 130 (W) mm	4" (L) x 5-1/8" (W)	
Gross Weight	4.9 kg	10.8 Lbs.	
Leadwire Length	150 mm or 320 mm	5-7/8" for 115 V	

Please read the page of "How to Use This Catalog" first for correct use of compressors and pumps.

Application Examples

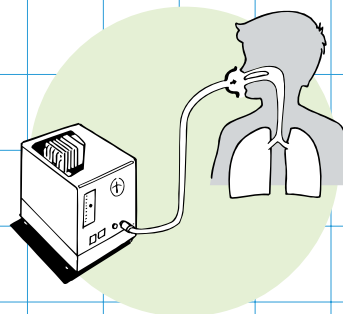

Oxygen Concentrator

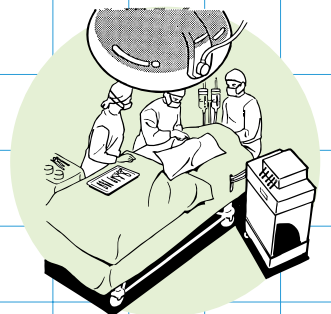

I.V. Balloon Pump

Sketch Drawing and Mounting Dimensions Diagram (mm)

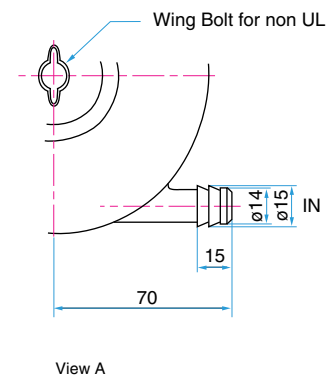
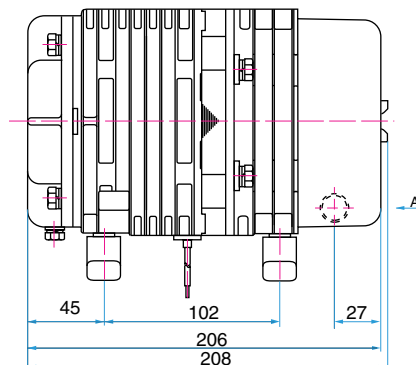
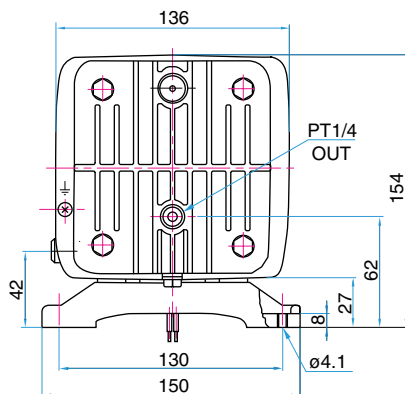





VACUUM PUMP

# AC LINEAR

## Piston Vacuum Pump

VP0125  
P39

VP0140  
P40

VP0435A  
P41

VP0450  
P42

VP 0625  
P43

VP 0660  
P44

VP0940  
P45



VACUUM PUMP

# LINEAR

# VP0125



MOTOR FREE  
PISTON SYSTEM



Airflow & Power Consumption

Specifications

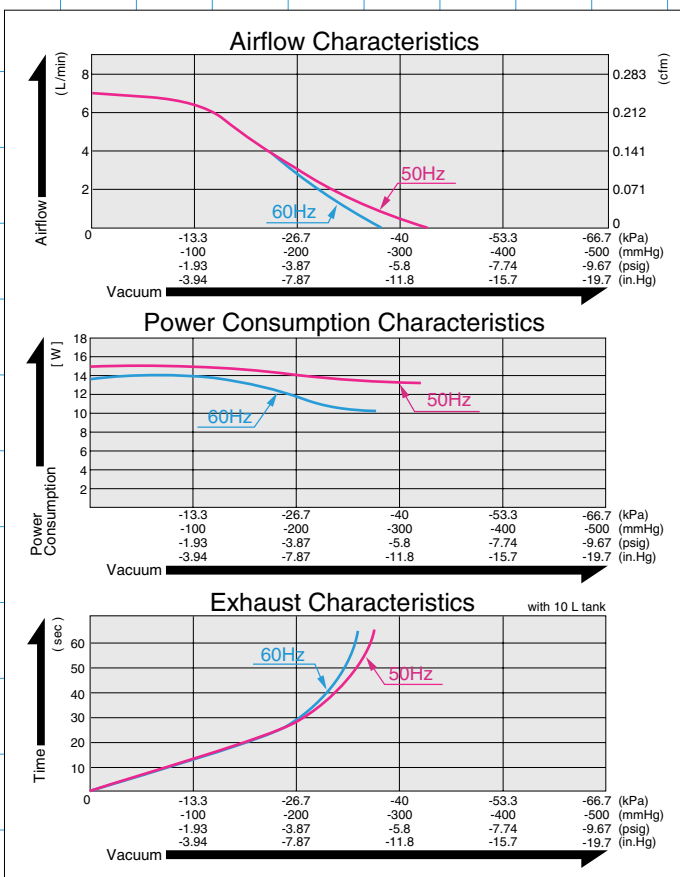

	(SI)	(EURO)	(U.S.A.)
Attainable Vacuum	-33.3 kPa (-250 mmHg)	-333 mbar	-9.84 in.Hg
Free Air Displacement	7 L/min		0.247 cfm
Rated Voltage	115 V AC or 230 V AC		
Power Consumption	14 W or 15 W		
Rated Frequency	60 Hz or 50 Hz		
Life Expectancy	3,000 hours		
Inlet	6 mm O.D. hose nipple		
Outlet	6 mm O.D. hose nipple		
Duty Cycle	Continuous		
Coil Insulation Class	E or its equivalent (JETL) and B for UL		
Mounting Dimensions	48 (L) x 62 (W) mm	1-7/8"(L) x 2-7/16"(W)	
Gross Weight	0.7 kg		1.54 Lbs.
Leadwire Length	200 mm		

Please read the page of "How to Use This Catalog" first for correct use of compressors and pumps.

Application Examples

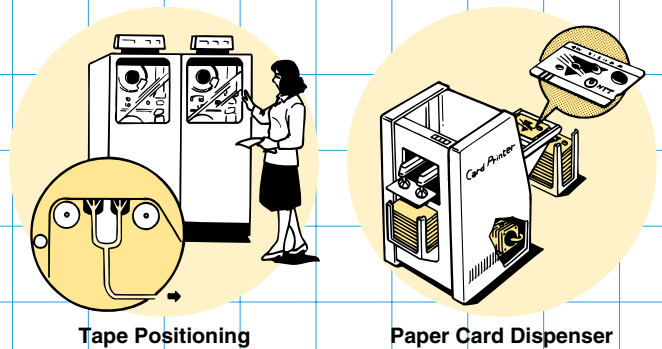

Sketch Drawing and Mounting Dimensions Diagram (mm)

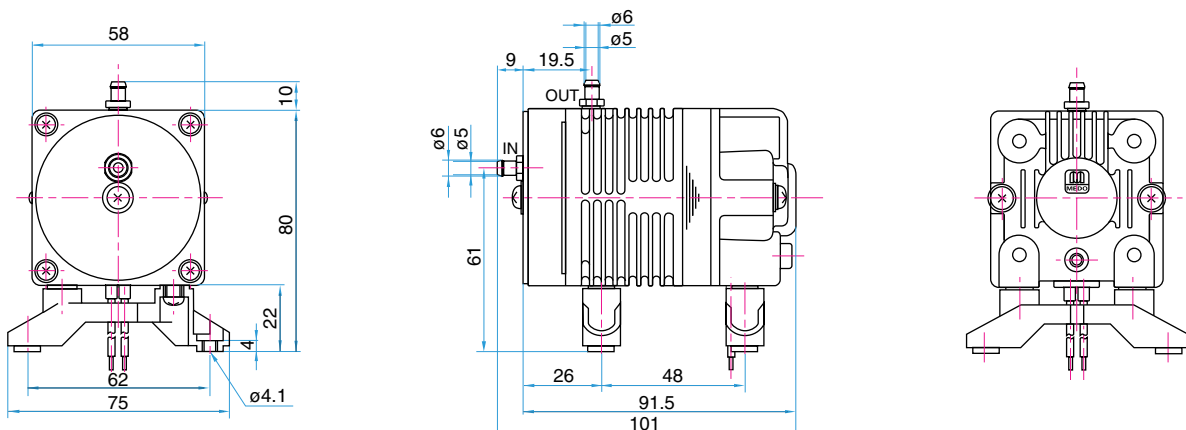



VACUUM PUMP

# LINEAR

# VP0140



**MOTOR FREE  
PISTON SYSTEM**



**Airflow & Power Consumption**

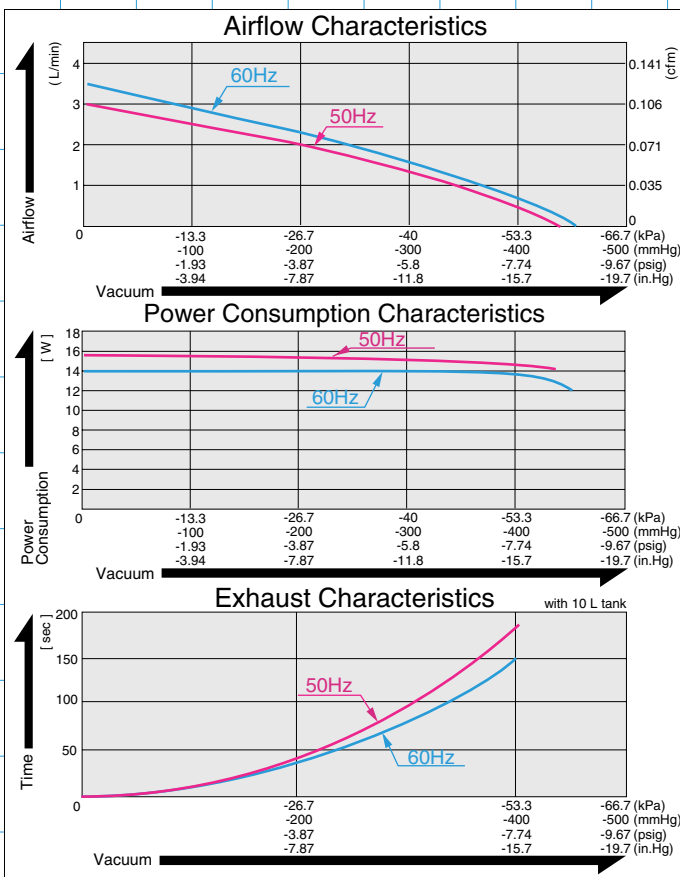

**Specifications**

	(SI)	(EURO)	(U.S.A.)
Attainable Vacuum**1	-53.3 kPa (-400 mmHg)	-533 mbar	-15.7 in.Hg
Free Air Displacement	3 L/min		0.106 cfm
Rated Voltage	115 V AC or 230 V AC		
Power Consumption	14 W or 15 W		
Rated Frequency	60 Hz or 50 Hz		
Life Expectancy	3,000 hours		
Inlet	6 mm O.D. hose nipple		
Outlet	6 mm O.D. hose nipple		
Duty Cycle	60 minutes		
Coil Insulation Class	E or its equivalent (JETL) and B for UL		
Mounting Dimensions	48 (L) x 62 (W) mm	1-7/8"(L) x 2-7/16"(W)	
Gross Weight	0.7 kg	1.54 Lbs.	
Leadwire Length	200 mm	7-7/8"	

\*\*1: Operations at higher than -53.5kPa need an additional leak valve or relief valve on the inlet piping. Please read the page of "How to Use This Catalog" first for correct use of compressors and pumps.

**Application Examples**

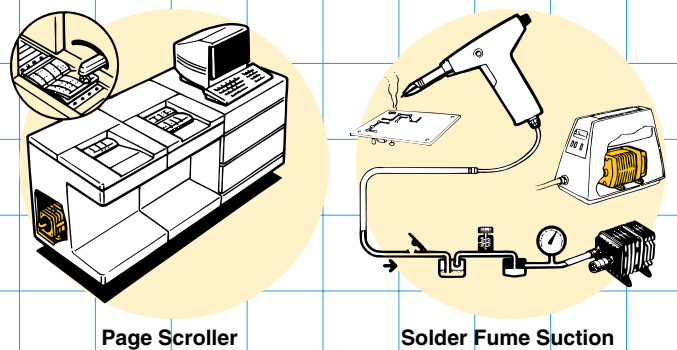

**Sketch Drawing and Mounting Dimensions Diagram (mm)**

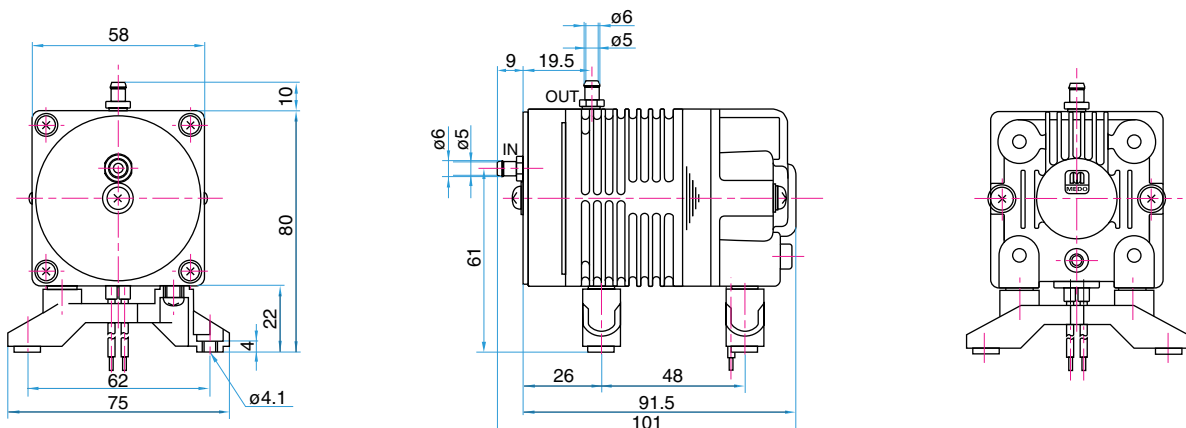

VACUUM PUMP

# LINEAR

# vp0435A



MOTOR FREE  
PISTON SYSTEM



Airflow & Power Consumption

Specifications

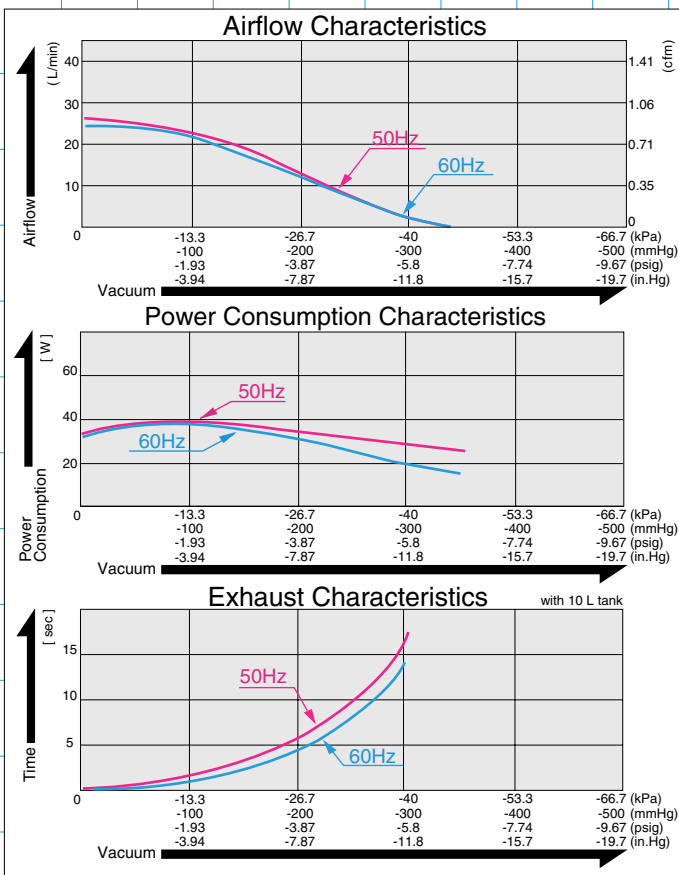

	(SI)	(EURO)	(U.S.A.)
Attainable Vacuum	-46.7 kPa (-350 mmHg)	-467 mbar	-13.78 in.Hg
Free Air Displacement	25 L/min		0.88 cfm
Rated Voltage	115 V AC or 230 V AC		
Power Consumption	39 W		
Rated Frequency	60 Hz or 50 Hz		
Life Expectancy	3,000 hours		
Inlet	ISO Rc 1/4 (female threaded)		
Outlet	ISO Rc 1/4 (female threaded)		
Duty Cycle	Continuous		
Coil Insulation Class	B or its equivalent (JETL) / UL		
Mounting Dimensions	68 (L) x 84 (W) mm	2-11/16" (L) x 3-5/16" (W)	
Gross Weight	2.3 kg	5.1 Lbs.	
Leadwire Length	200 mm	7-7/8"	

Please read the page of "How to Use This Catalog" first for correct use of compressors and pumps.

Application Examples

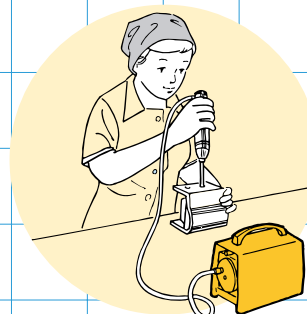

Machine Screw Feeder

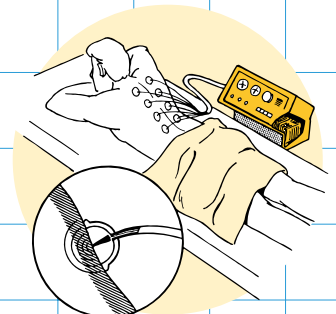

Medical Cup Suction

Sketch Drawing and Mounting Dimensions Diagram (mm)

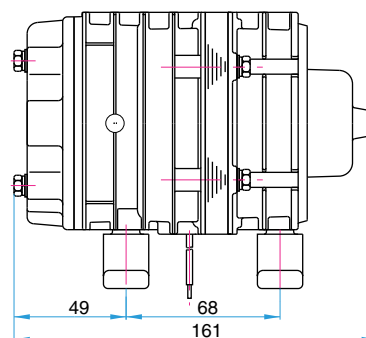
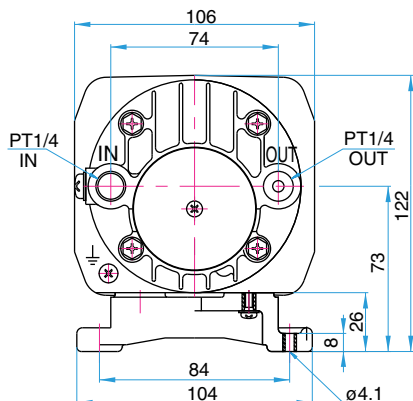

VACUUM PUMP

# LINEAR

# VP0450



MOTOR FREE  
PISTON SYSTEM



Airflow & Power Consumption

Specifications

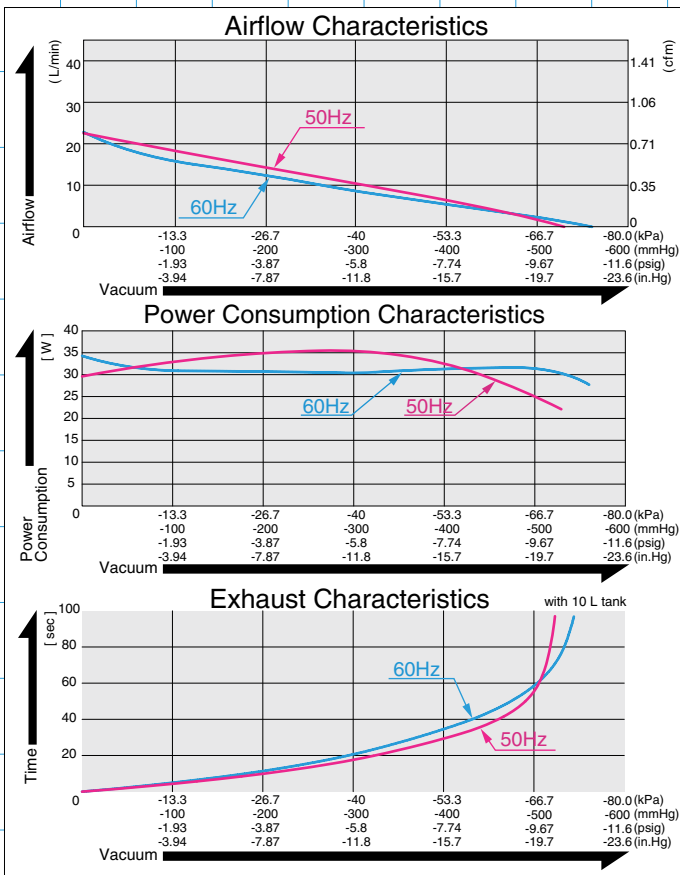

	(SI)	(EURO)	(U.S.A.)
Attainable Vacuum	-66.7 kPa (-500 mmHg)	-667 mbar	-19.7 in.Hg
Free Air Displacement	18 L/min		0.64 cfm
Rated Voltage	120 V AC or 230 V AC		
Power Consumption	34 W or 35 W		
Rated Frequency	60 Hz or 50 Hz		
Life Expectancy	10,000 hours		
Inlet	ISO Rc 1/4 (female threaded)		
Outlet	ISO Rc 1/4 (female threaded)		
Duty Cycle	Continuous		
Coil Insulation Class	E or its equivalent (JETL)		
Mounting Dimensions	85 (L) x 88 (W) mm	3-11/32" (L) x 3-15/32" (W)	
Gross Weight	2.2 kg	4.9 Lbs.	
Leadwire Length	300 mm	11-13/16"	

Please read the page of "How to Use This Catalog" first for correct use of compressors and pumps.

Application Examples

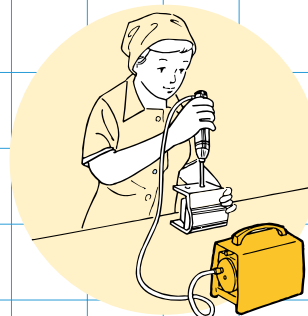

Machine Screw Feeder

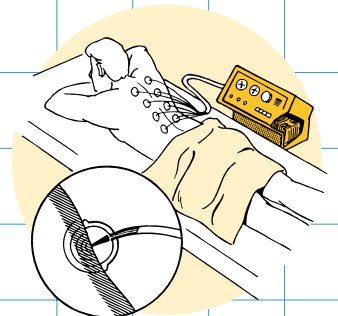

Medical Cup Suction

Sketch Drawing and Mounting Dimensions Diagram (mm)

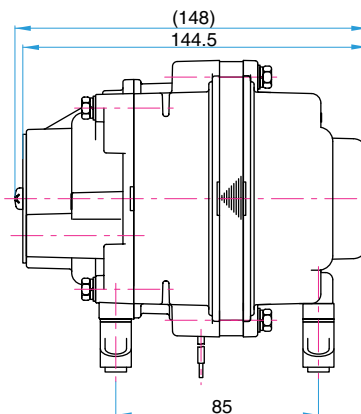
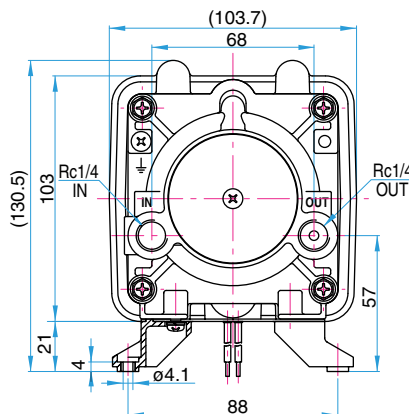

VACUUM PUMP

# LINEAR

# VP0625



MOTOR FREE  
PISTON SYSTEM



Airflow & Power Consumption

Specifications

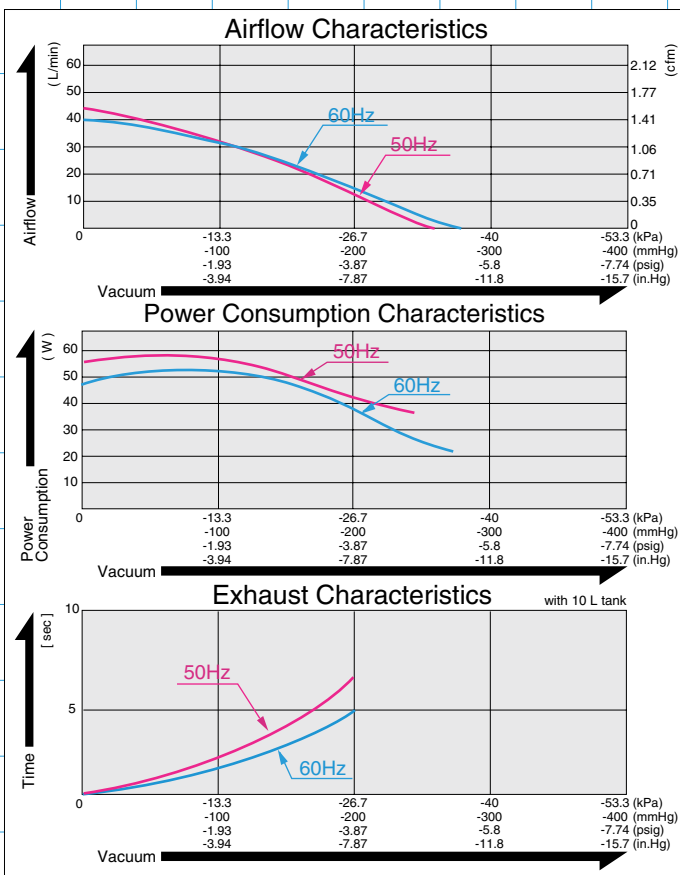

	(SI)	(EURO)	(U.S.A.)
Attainable Vacuum	-33.3 kPa (-250 mmHg)	-333 mbar	-9.84 in.Hg
Free Air Displacement	40 L/min		1.41 cfm
Rated Voltage	115 V AC or 230 V AC		
Power Consumption	56 W or 60 W		
Rated Frequency	60 Hz or 50 Hz		
Life Expectancy	10,000 hours		
Inlet	15 mm O.D. hose nipple		
Outlet	ISO Rc 1/4 (female threaded)		
Duty Cycle	Continuous		
Coil Insulation Class	E or its equivalent (JETL) or B for UL		
Mounting Dimensions	68 (L) x 84 (W) mm	2-11/16" (L) x 3-5/16" (W)	
Gross Weight	3 kg		
Leadwire Length	235 mm or 320 mm	9-13/16"	

Please read the page of "How to Use This Catalog" first for correct use of compressors and pumps.

Application Examples

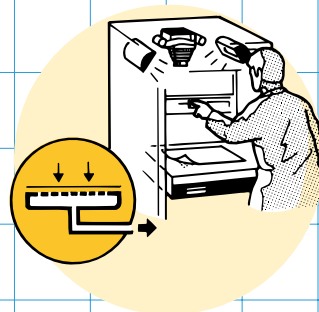

Microfiche Camera

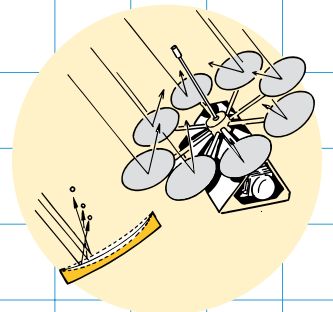

Solar Collection Screen

Sketch Drawing and Mounting Dimensions Diagram (mm)

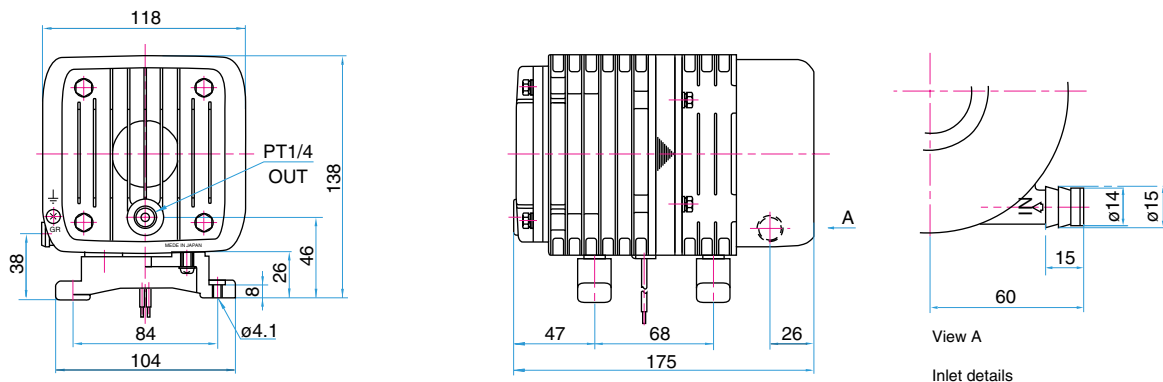

VACUUM PUMP

# LINEAR

# VP0660



MOTOR FREE  
PISTON SYSTEM



Airflow & Power Consumption

Specifications

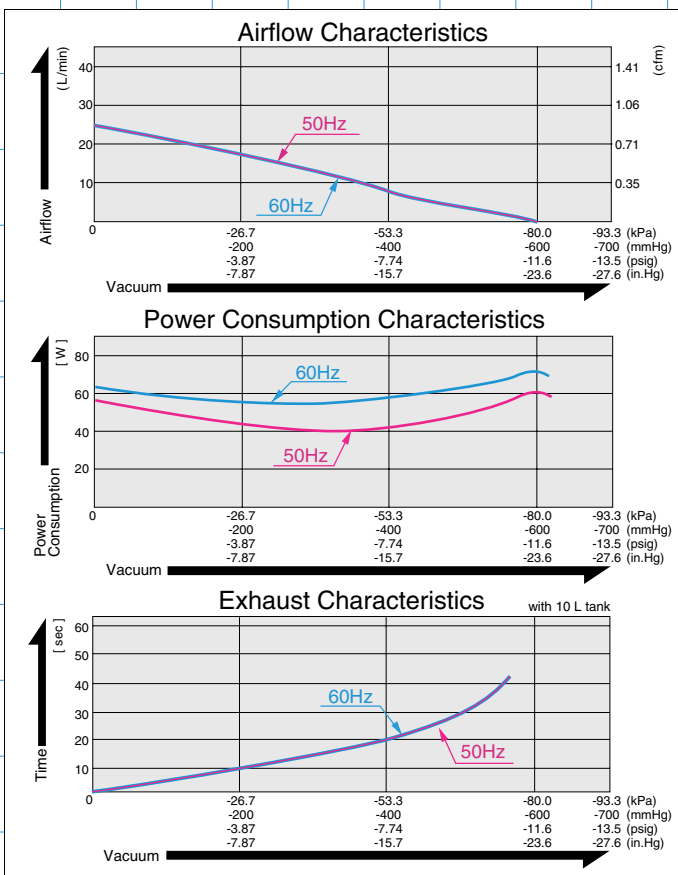

	(SI)	(EURO)	(U.S.A.)
Attainable Vacuum <sup>※1</sup>	-80 kPa (-600 mmHg)	-800 mbar	-23.6 in.Hg
Free Air Displacement	25 L/min		0.88 cfm
Rated Voltage	115 V AC or 230 V AC		
Power Consumption	70 W or 60 W		
Rated Frequency	60 Hz or 50 Hz		
Life Expectancy	6,000 hours		
Inlet	ISO Rc 1/4 (female threaded)		
Outlet	ISO Rc 1/4 (female threaded)		
Duty Cycle	Continuous		
Coil Insulation Class	E or its equivalent (JETL) or B for UL		
Mounting Dimensions	102 (L) x 130 (W) mm	4"(L) x 5-1/8"(W)	
Gross Weight	5 kg	11 Lbs.	
Leadwire Length	300 mm or 600 mm	5-7/8"	

※1: Operations at higher than -80kPa need an additional leak valve or relief valve on the inlet piping. Please read the page of "How to Use This Catalog" first for correct use of compressors and pumps.

Application Examples

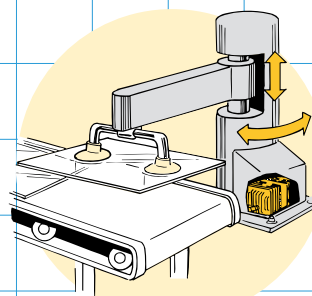

Material Handling Machine

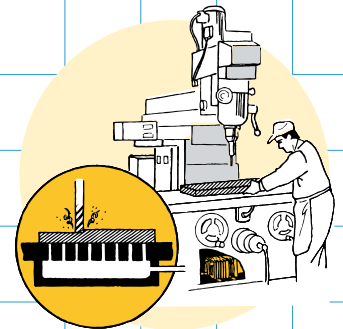

Vacuum Chucking

Sketch Drawing and Mounting Dimensions Diagram (mm)

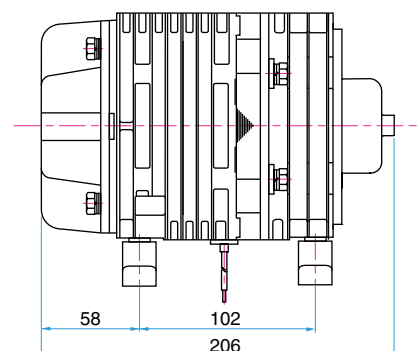
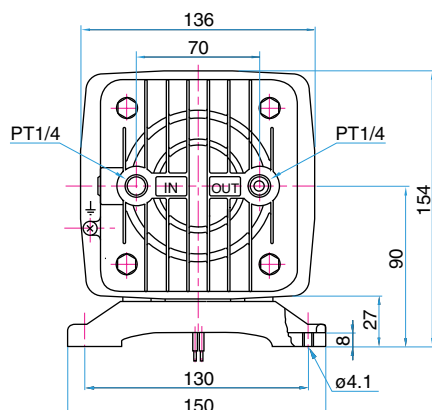

VACUUM PUMP

# LINEAR

# VP0940



MOTOR FREE  
PISTON SYSTEM



Airflow & Power Consumption

Specifications

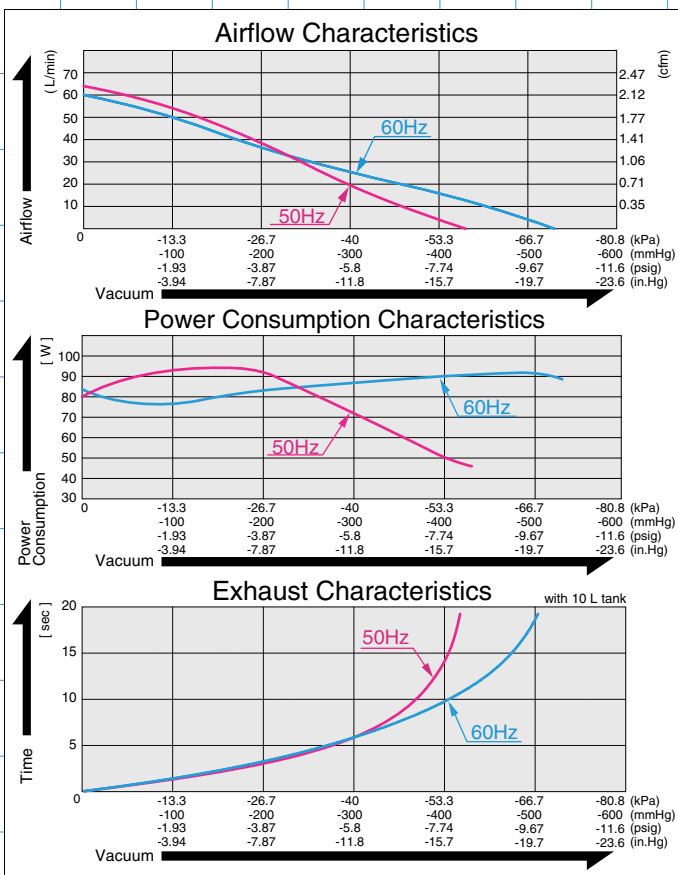

	(SI)	(EURO)	(U.S.A.)
Attainable Vacuum**1	-53.3 kPa (-400 mmHg)	-533 mbar	-15.7 in.Hg
Free Air Displacement	60 L/min		2.12 cfm
Rated Voltage	120 V AC or 230 V AC		
Power Consumption	95 W		
Rated Frequency	60 Hz & 50 Hz		
Life Expectancy	10,000 hours		
Inlet	ISO Rc 1/4 (female threaded)		
Outlet	ISO Rc 1/4 (female threaded)		
Duty Cycle	Continuous		
Coil Insulation Class	B or its equivalent (JETL)		
Mounting Dimensions	102 (L) x 130 (W) mm	4"(L) x 5-1/8"(W)	
Gross Weight	4.55 kg	10.0 Lbs.	
Leadwire Length	300 mm	11-13/16"	

※ 1: Operations at higher than -53.5kPa need an additional leak valve or relief valve on the inlet piping. Please read the page of "How to Use This Catalog" first for correct use of compressors and pumps.

Application Examples

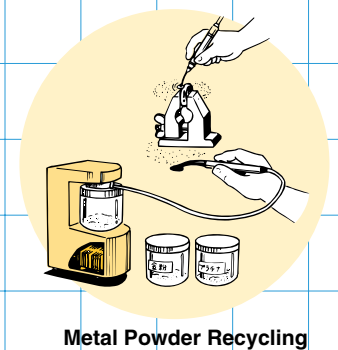

Sketch Drawing and Mounting Dimensions Diagram (mm)

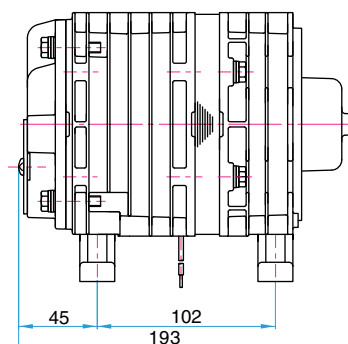
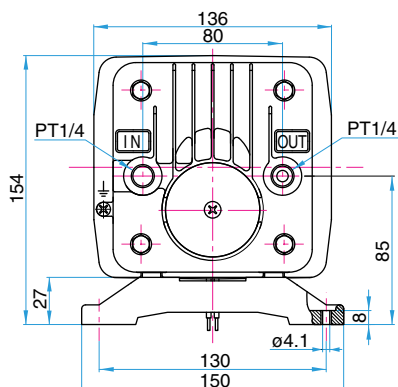

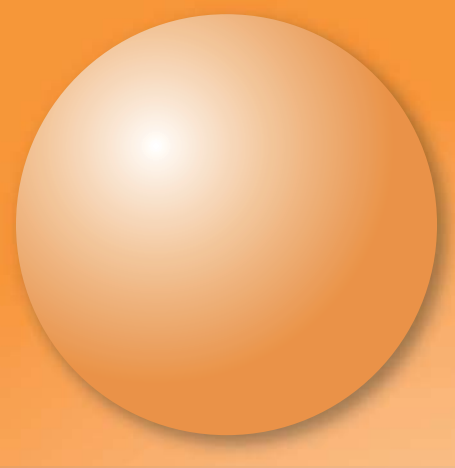

**LA BLOWER**

# **AC LINEAR**

## **Piston Blower**

LA-28B  
LA-45B  
P47

LA-60B  
LA-80B  
P48

LA-100A  
LA-120A  
P49

LAM-200  
P50

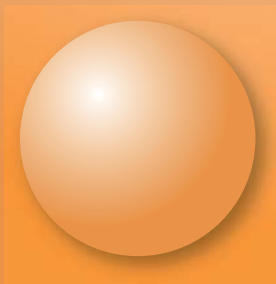
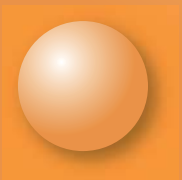

# LINEAR



MOTOR FREE  
PISTON SYSTEM



# LA-28B LA-45B

### Airflow Characteristics

### Specifications

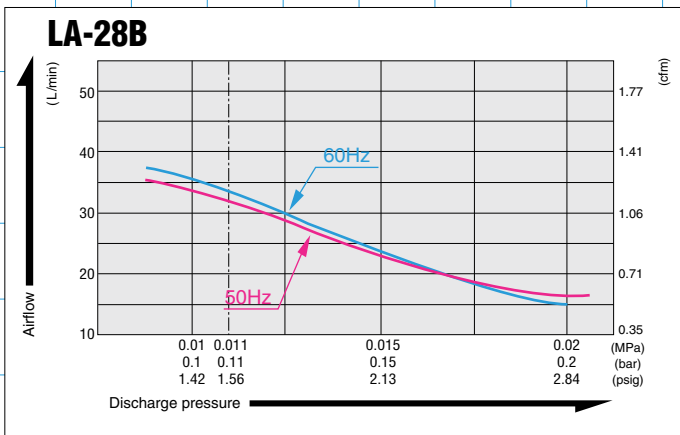

	LA-28B	LA-45B
Power Supply	120 V, 220 V, 230 V, 240 V AC	
Rated Frequency	50 Hz, 60 Hz	
Rated Pressure	0.011 MPa {0.11kgf/cm <sup>2</sup> }, 0.11 bar or 1.56 psig	
Rated Airflow	28 L/min {0.99 cfm}	45 L/min {1.59 cfm}
Power Consumption	29 W / 50 Hz 25.5 W / 60 Hz	47 W / 50 Hz 45 W / 60 Hz
Weight	2.9 kg {6.4 lbs}	3.0 kg {6.6 lbs}

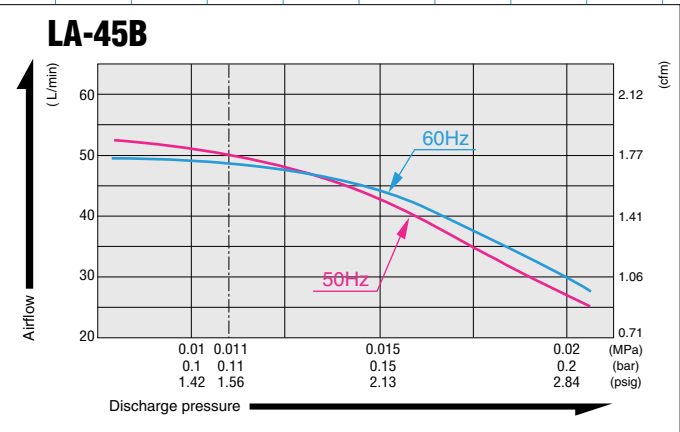

### Application Examples

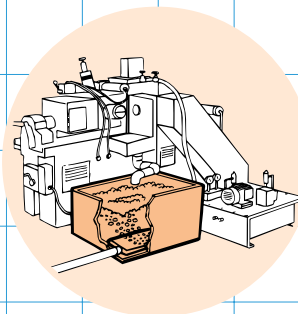

Liquid Mixer Bubbling

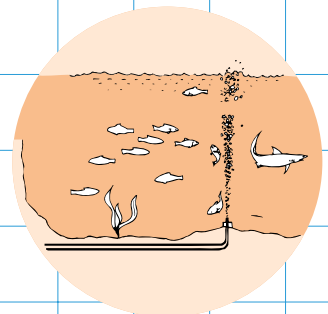

Fish Farm Aquatic Fence

### Sketch Drawing and Mounting Dimensions Diagram (mm)

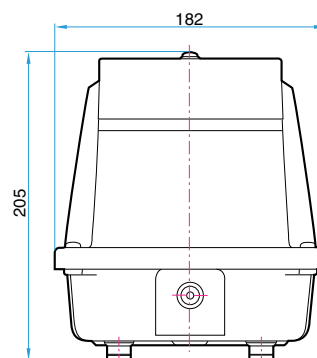
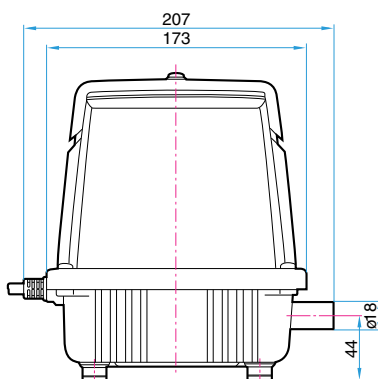



# LINEAR



MOTOR FREE  
PISTON SYSTEM



# LA-60B LA-80B

## Airflow Characteristics

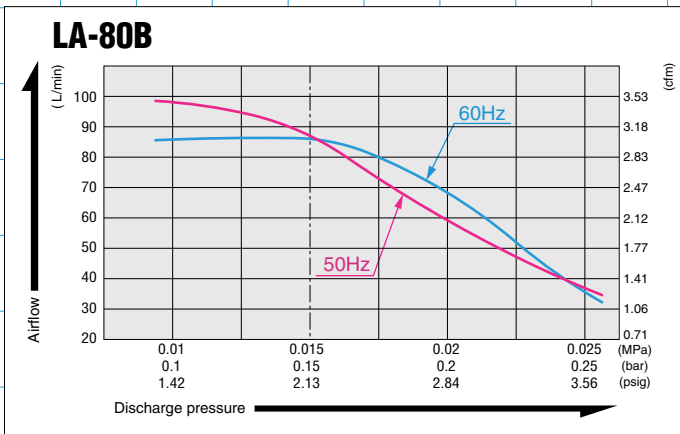
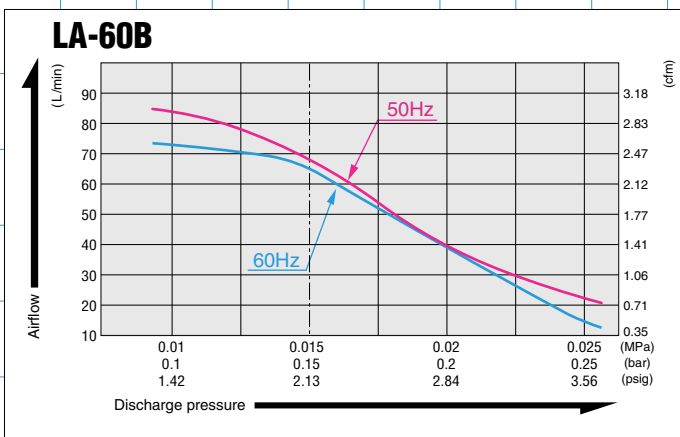

## Specifications

	LA-60B	LA-80B
Power Supply	120 V, 220 V, 230 V, 240 V AC	
Rated Frequency	50 Hz, 60 Hz	
Rated Pressure	0.015 MPa {0.15kgf/cm <sup>2</sup> }, 0.15 bar or 2.13 psig	
Rated Airflow	60 L/min {2.12 cfm}	80 L/min {2.83 cfm}
Power Consumption	64 W / 50 Hz	86 W / 50 Hz
	60 W / 60 Hz	86 W / 60 Hz
Weight	5.0 kg {11 lbs}	5.3 kg {11.7 lbs}

## Application Examples

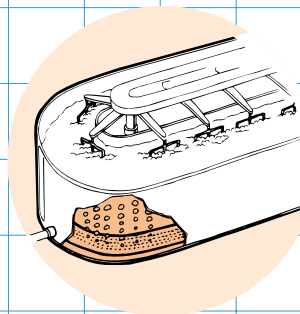

Liquid Mixer Bubbling

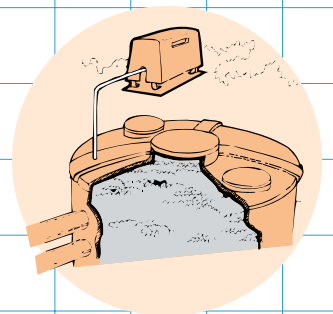

Home Aerobic Sewage Treatment System

## Sketch Drawing and Mounting Dimensions Diagram (mm)

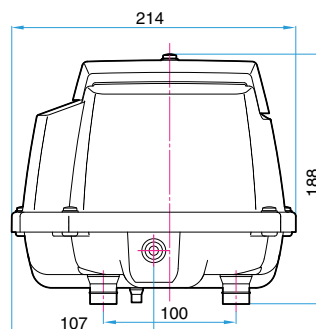
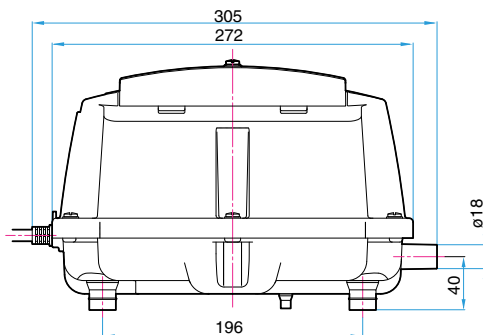

# LINEAR



MOTOR FREE  
PISTON SYSTEM



# LA-100A LA-120A

## Airflow Characteristics

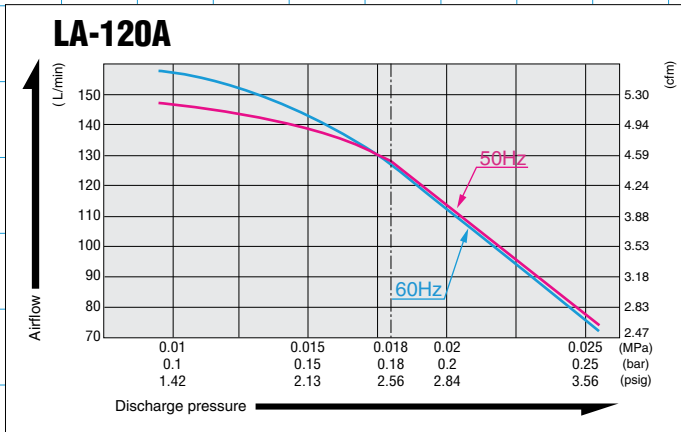
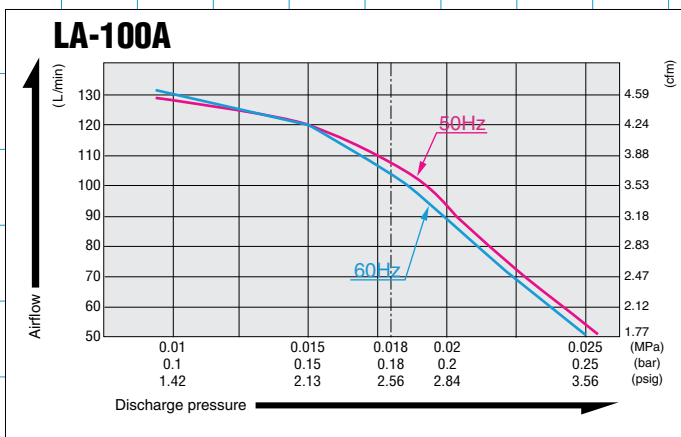

## Specifications

	LA-100A	LA-120A
Power Supply	120 V, 220 V, 230 V, 240 V AC	
Rated Frequency	50 Hz, 60 Hz	
Rated Pressure	0.018 MPa {0.18kgf/cm <sup>2</sup> }, 0.18 bar or 2.56 psig	
Rated Airflow	100 L/min {3.53 cfm}	120 L/min {4.24 cfm}
Power Consumption	100 W / 50 Hz	130 W / 50 Hz
	95 W / 60 Hz	118 W / 60 Hz
Weight	9.7 kg {21.4 lbs}	9.7 kg {21.4 lbs}

## Application Examples

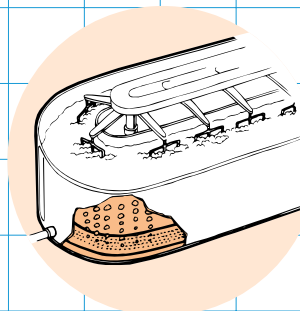

Liquid Mixer Bubbling

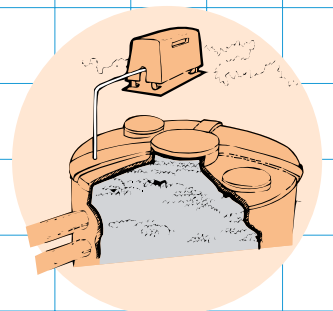

Home Aerobic Sewage Treatment System

## Sketch Drawing and Mounting Dimensions Diagram (mm)

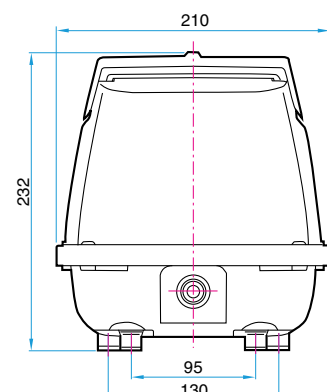
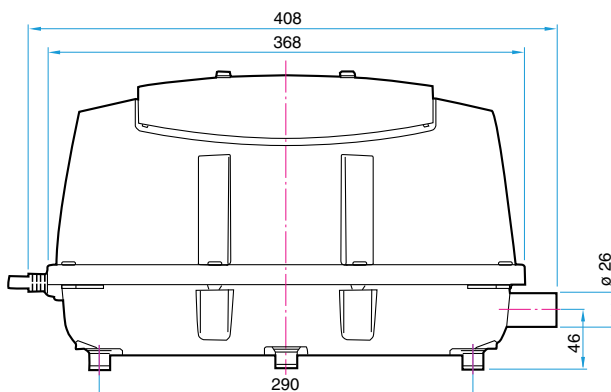

# LINEAR

# LAM-200



MOTOR MAGNET  
PISTON SYSTEM



### Airflow Characteristics

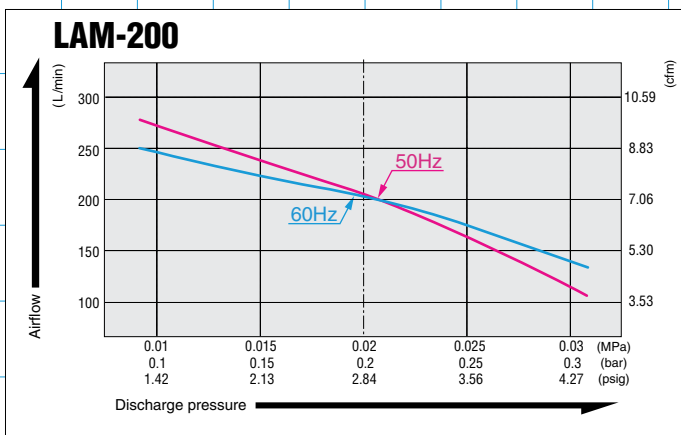

### Specifications

LAM-200	
Power Supply	120 V, 220 V, 230 V, 240 V AC
Rated Frequency	50 Hz, 60Hz
Rated Pressure	0.020 MPa {0.20 kgf/cm <sup>2</sup> }, 0.20 bar or 2.84 psig
Rated Airflow	200 L/min {7.06 cfm}
Power Consumption	215 W / 50 Hz 215 W / 60 Hz
Weight	12.3 kg {27.1 lbs}

### Application Examples

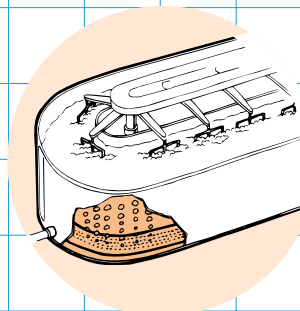

Liquid Mixer Bubbling

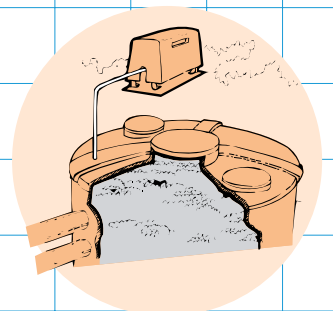

Home Aerobic Sewage Treatment System

### Sketch Drawing and Mounting Dimensions Diagram (mm)

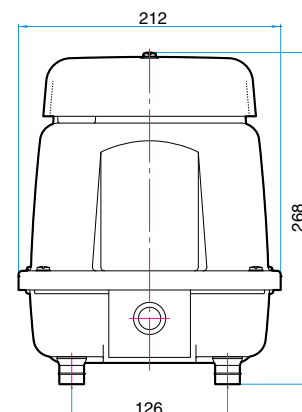
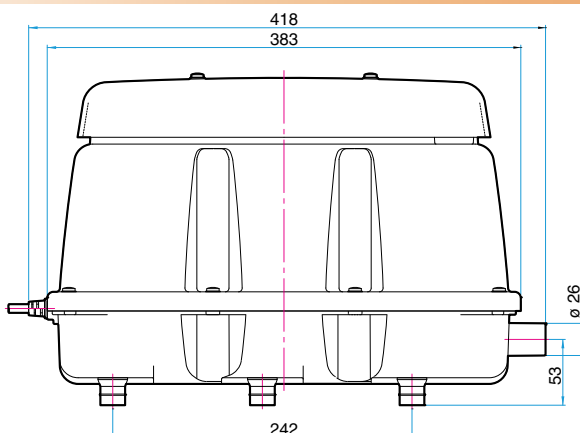





# DIAPHRAGM PUMP

# AG LINEAR Diaphragm Pump

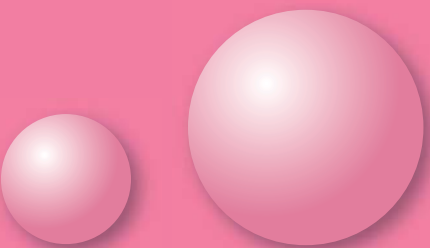

- VC0100  
Dual Type  
P53
- VC0100  
Blower Type  
P54
- VC0101  
Dual Type  
P55
- VC0101  
Blower Type  
P56
- VC0101E  
Dual Type  
P57
- VC0101E  
Blower Type  
P58
- VC0201  
Dual Type  
P59
- VC0201  
Blower Type  
P60
- VC0301  
Dual Type  
P61
- VC0301  
Blower Type  
P62
- VC0201B  
Dual Type  
P63
- VC0201B  
Blower Type  
P64
- VC0301B  
Dual Type  
P65
- VC0301B  
Blower Type  
P66

# DIAPHRAGM PUMP

## DIAPHRAGM PUMP



# vc0100 Dual Type

### Airflow & Power Consumption

### Specifications

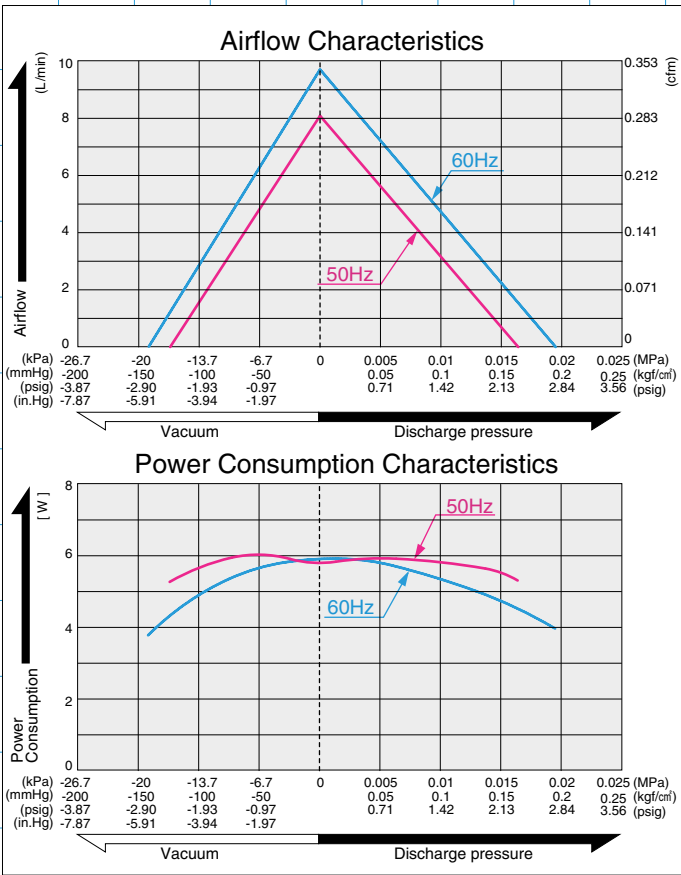

	(SI)	(EURO)	(U.S.A.)
Rated Pressure	0.004 MPa {0.04 kgf/cm <sup>2</sup> }	0.04 bar	0.57 psig
Rated Airflow	6 L/min		0.21 cfm
Rated Voltage	120 V AC or 230 V AC		
Maximum Pressure	0.016 MPa {0.16 kgf/cm <sup>2</sup> }	0.16 bar	2.28 psig
Maximum Vacuum	-14.7 kPa {-110 mmHg}	-147 mbar	-4.33 in.Hg
Power Consumption	6 W		
Rated Frequency	60 Hz or 50 Hz		
Life Expectancy	5,000 hours		
Working Pressure Range	-14.7 kPa~0.016 MPa {-110 mmHg~0.16 kgf/cm <sup>2</sup> }	-147 mbar~	-4.33 in.Hg~
Outlet (or Inlet)	6 mm O.D. hose nipple		
Duty Cycle	Continuous		
Coil Insulation Class	E for 230V & A for 120V or its equivalent		
Mounting Dimensions	70 (L) x 72 (W) mm	2-3/4"(L) x 2-7/8"(W)	
Gross Weight	0.45 kg	0.99 Lbs.	
Leadwire Length	300 mm	11-13/16"	

Please read the page of "How to Use This Catalog" first for correct use of compressors and pumps.

### Application Examples

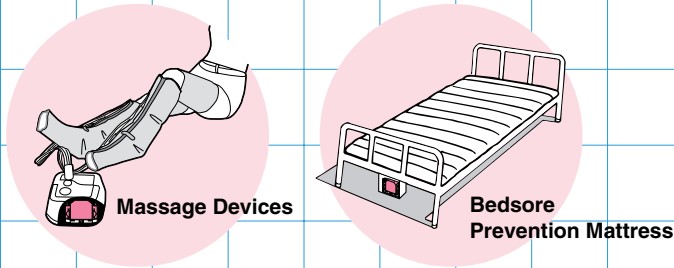

### Sketch Drawing and Mounting Dimensions Diagram (mm)

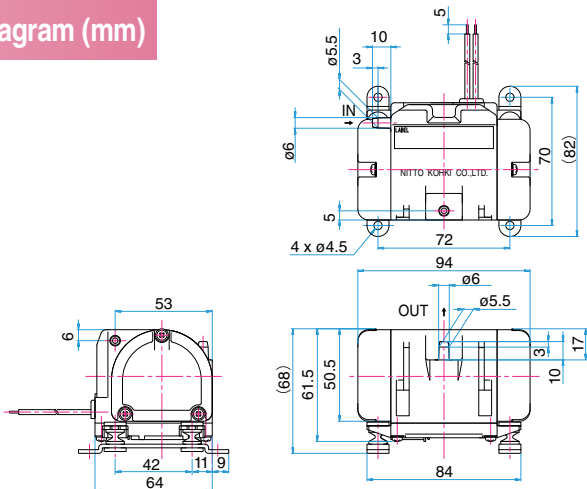

# DIAPHRAGM PUMP

## DIAPHRAGM PUMP



# vc0100 Blower Type

### Airflow & Power Consumption

### Specifications

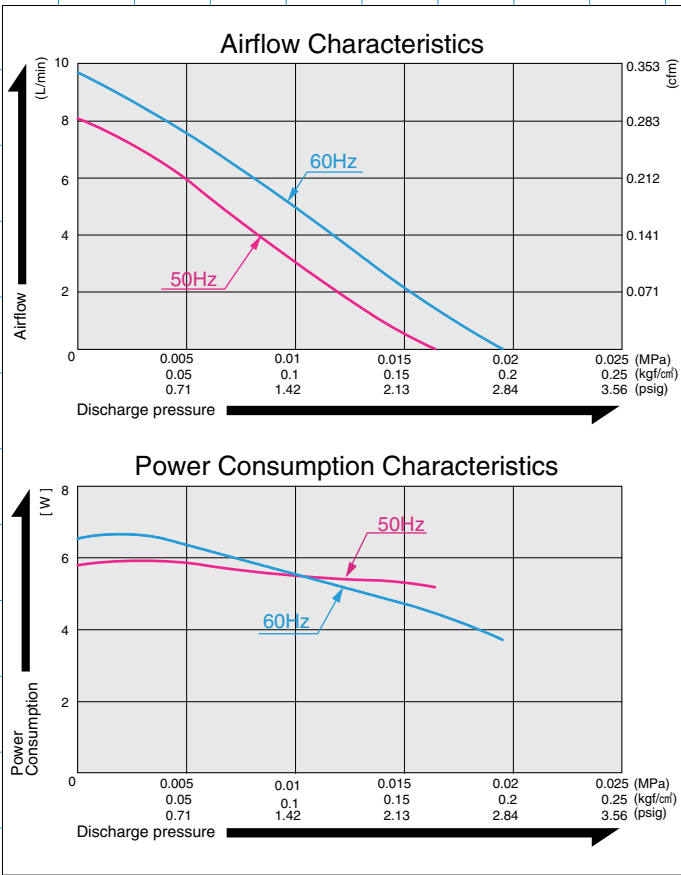

	(SI)	(EURO)	(U.S.A.)
Rated Pressure	0.004 MPa {0.04 kgf/cm <sup>2</sup> }	0.04 bar	0.57 psig
Rated Airflow	6 L/min		0.21 cfm
Rated Voltage	120 V AC or 230 V AC		
Maximum Pressure	0.016 MPa {0.16 kgf/cm <sup>2</sup> }	0.16 bar	2.28 psig
Power Consumption	6 W		
Rated Frequency	60 Hz or 50 Hz		
Life Expectancy	10,000 hours		
Working Pressure Range	0~0.016 MPa {0~0.16 kgf/cm <sup>2</sup> }	0~0.16 bar	0~2.28 psig
Outlet (or Inlet)	6 mm O.D. hose nipple		
Duty Cycle	Continuous		
Coil Insulation Class	E for 230V & A for 120V or its equivalent		
Mounting Dimensions	70 (L) x 72 (W) mm	2-3/4"(L) x 2-7/8"(W)	
Gross Weight	0.45 kg		0.99 Lbs.
Leadwire Length	300 mm		11-13/16"

Please read the page of "How to Use This Catalog" first for correct use of compressors and pumps.

### Application Examples

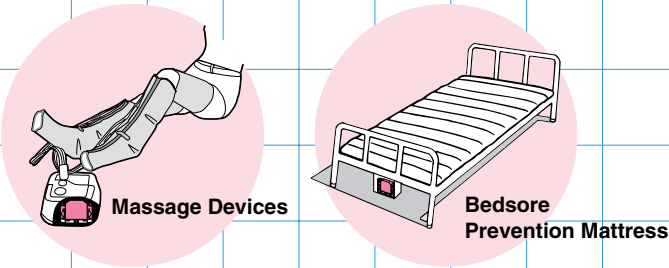

### Sketch Drawing and Mounting Dimensions Diagram (mm)

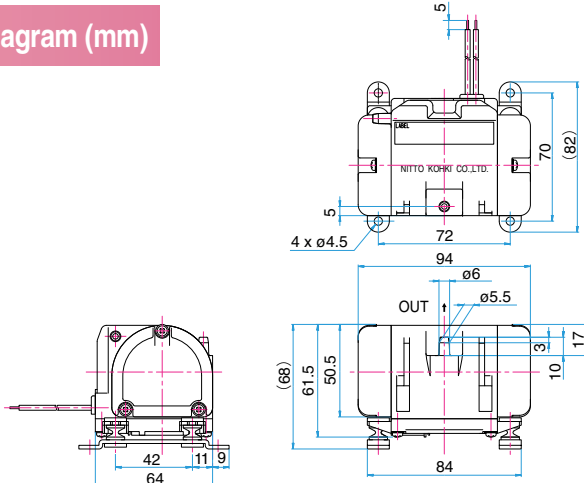

# DIAPHRAGM PUMP

## DIAPHRAGM PUMP



# vc0101 Dual Type

### Airflow & Power Consumption

### Specifications

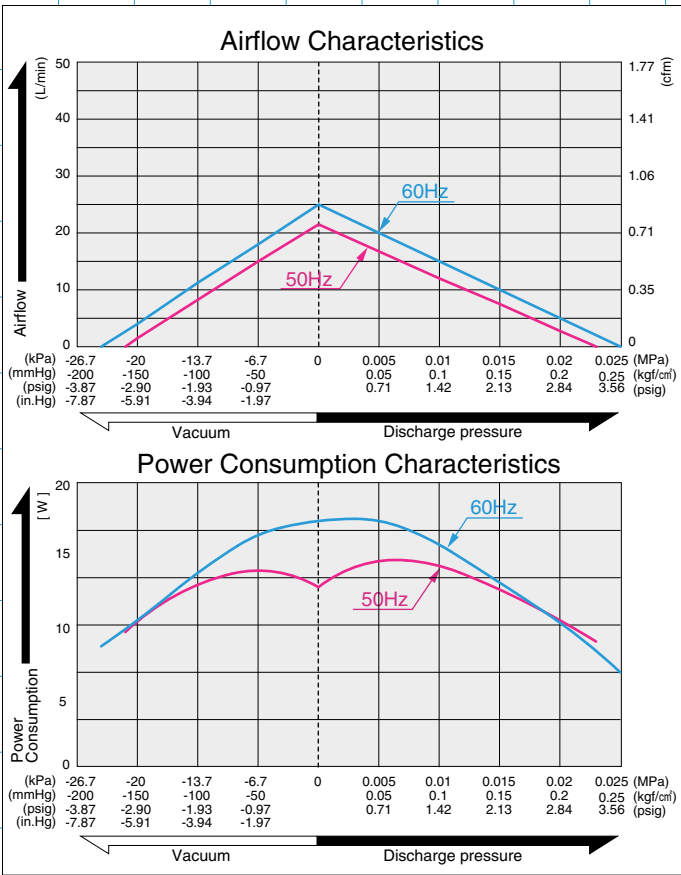

VC0101	(SI)	(EURO)	(U.S.A.)
Rated Pressure	0.01 MPa {0.1 kgf/cm <sup>2</sup> }	0.1 bar	1.42 psig
Rated Airflow	10 L/min		0.35 cfm
Rated Voltage	120 V AC or 230 V AC		
Maximum Pressure	0.018 MPa (0.18 kgf/cm <sup>2</sup> )	0.18 bar	2.56 psig
Maximum Vacuum	-18.7 kPa (-140mmHg)	-187 mbar	-5.51 in.Hg
Working Pressure Range	-18.7 kPa~0.018 MPa (-140 mmHg~0.18 kgf/cm <sup>2</sup> )	-187 mbar~0.18 bar	-5.51 in.Hg~2.56 psig
Maximum Pressure	0.015 MPa (0.15 kgf/cm <sup>2</sup> )	0.15 bar	2.13 psig
Maximum Vacuum	-10 kPa (-76mmHg)	-100 mbar	-2.95 in.Hg
Working Pressure Range	-10kPa~0.015 MPa (-76mmHg~0.15 kgf/cm <sup>2</sup> )	-100 mbar~0.15 bar	-2.95 in.Hg~2.13 psig
Power Consumption	11W		
Rated Frequency	60 Hz or 50 Hz		
Life Expectancy	5,000 hours		
Outlet (Inlet)	7.5 mm O.D. hose nipple		
Duty Cycle	Continuous		
Coil Insulation Class	B for 230V & A for 120V or its equivalent		
Mounting Dimensions	66 (L) x 100 (W) mm	2 <sup>-19/32</sup> "(L) x 3 <sup>-15/16</sup> "(W)	
Gross Weight	0.82 kg		1.8 Lbs.
Leadwire Length	200 mm		7-7/8"

Please read the page of "How to Use This Catalog" first for correct use of compressors and pumps.

### Application Examples

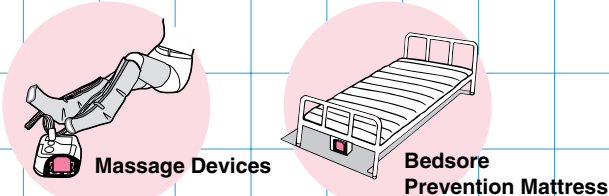

### Sketch Drawing and Mounting Dimensions Diagram (mm)

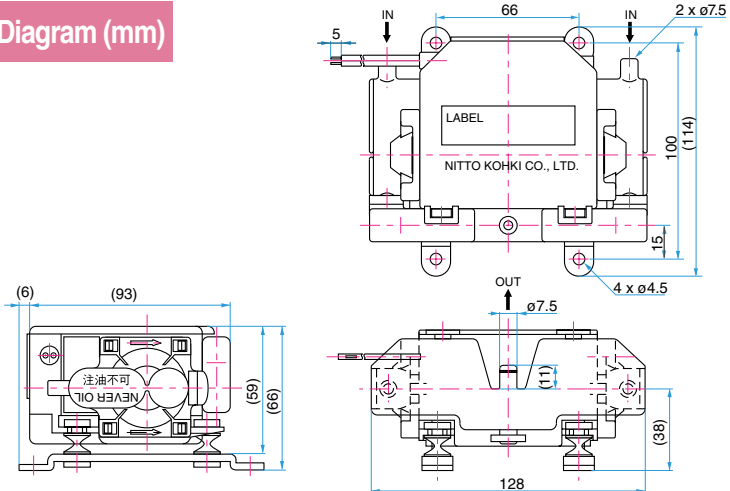



# DIAPHRAGM PUMP

## DIAPHRAGM PUMP



# vc0101 Blower Type

### Airflow & Power Consumption

### Specifications

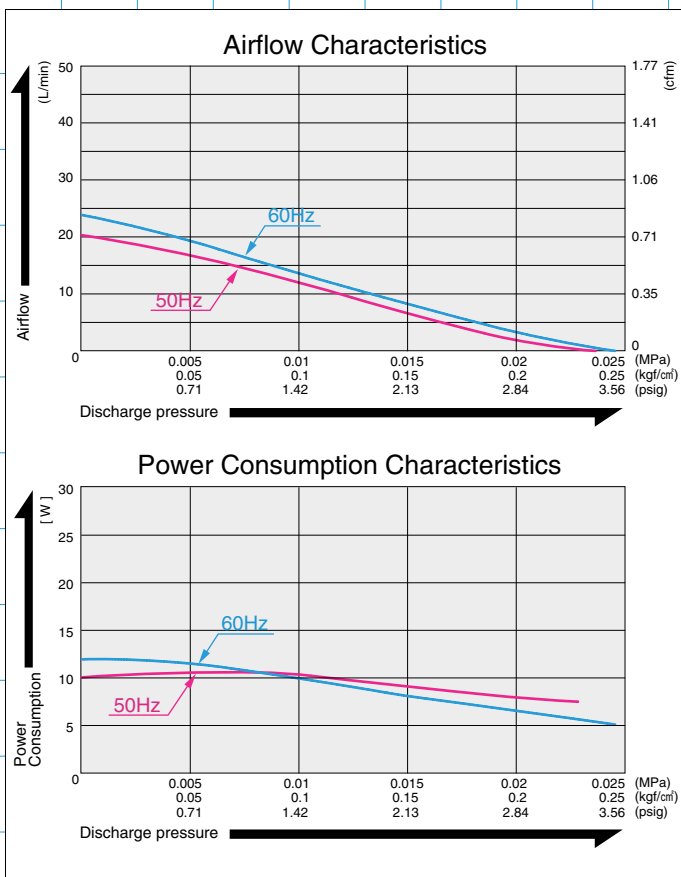

VC0101	(SI)	(EURO)	(U.S.A.)
Rated Pressure	0.01 MPa (0.1 kgf/cm <sup>2</sup> )	0.1 bar	1.42 psig
Rated Airflow	10 L/min		0.35 cfm
Rated Voltage	120 V AC or 230 V AC		
Maximum Pressure	0.02 MPa (0.2 kgf/cm <sup>2</sup> )	0.2 bar	2.84 psig
Working Pressure Range	0~0.02 MPa (0~0.2 kgf/cm <sup>2</sup> )	0~0.2 bar	0~2.84 psig
Power Consumption	11W		
Rated Frequency	60 Hz or 50 Hz		
Life Expectancy	10,000 hours		
Outlet (Inlet)	7.5 mm O.D. hose nipple		
Duty Cycle	Continuous		
Coil Insulation Class	B for 230V & A for 120V or its equivalent		
Mounting Dimensions	66 (L) x 100 (W) mm	2-19/32"(L) x 3-15/16"(W)	
Gross Weight	0.82 kg	1.8 Lbs.	
Leadwire Length	200 mm	7-7/8"	

Please read the page of "How to Use This Catalog" first for correct use of compressors and pumps.

### Application Examples

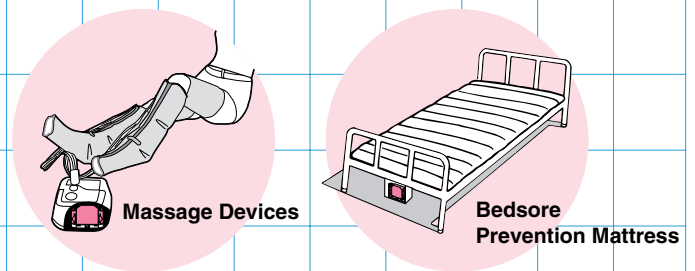

### Sketch Drawing and Mounting Dimensions Diagram (mm)

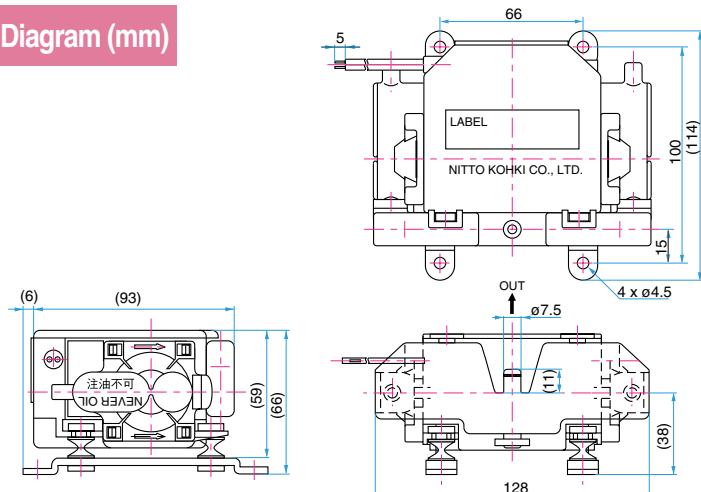

# DIAPHRAGM PUMP

## DIAPHRAGM PUMP



# vc0101E Dual Type

### Airflow & Power Consumption

### Specifications

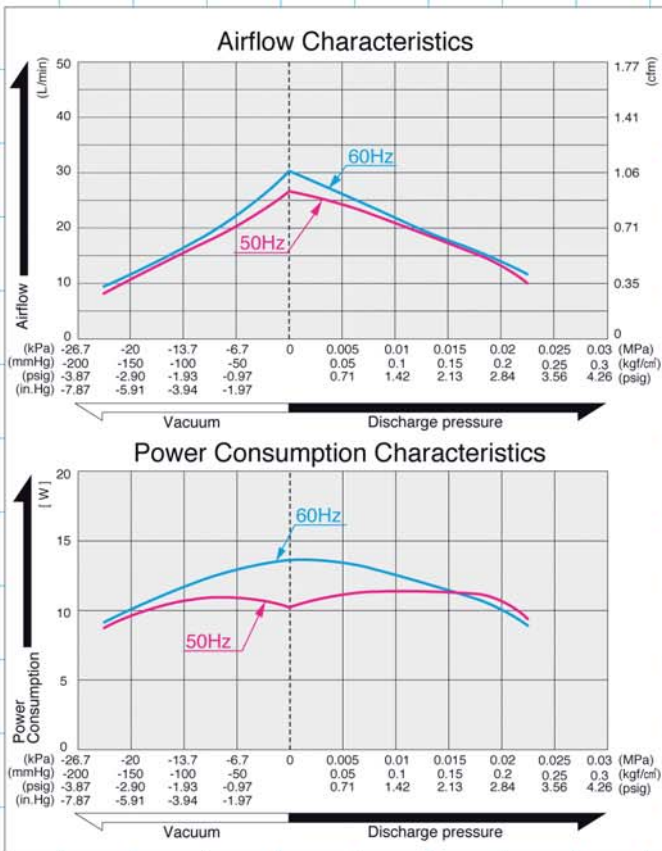

VC0101E	(SI)	(EURO)	(U.S.A.)
Rated Pressure	0.01 MPa (0.1 kgf/cm <sup>2</sup> )	0.1 bar	1.42 psig
Rated Airflow	15 L/min		0.53 cfm
Rated Voltage	120 V AC <sup>※1</sup> or 230 V AC		
Maximum Pressure	0.02 MPa (0.2 kgf/cm <sup>2</sup> )	0.2 bar	2.84 psig
Maximum Vacuum	-18.7 kPa (-140mmHg)	-186 mbar	-5.51 in.Hg
Power Consumption	11.5 W		
Rated Frequency	60 Hz or 50 Hz		
Life Expectancy	5,000 hours		
Working Pressure Range	-18.7kPa~0.02 MPa (-140mmHg~0.2 kgf/cm <sup>2</sup> )	-186 mbar~0.2 bar	-5.51 in.Hg~2.84 psig
Outlet (Inlet)	7.5 mm O.D. hose nipple		
Duty Cycle	Continuous		
Coil Insulation Class	E or its equivalent (JETL)		
Mounting Dimensions	66 (L) x 100 (W) mm	2-19/32"(L) x 3-15/16"(W)	
Gross Weight	0.82 kg		1.8 Lbs.
Leadwire Length	300 mm		11-13/16"

※1: 120V AC UL version is unavailable.  
Please read the page of "How to Use This Catalog" first for correct use of compressors and pumps.

### Application Examples

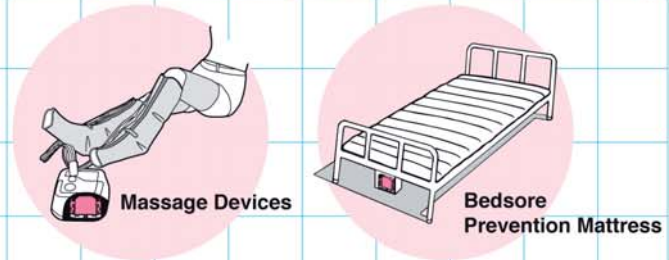

### Sketch Drawing and Mounting Dimensions Diagram (mm)

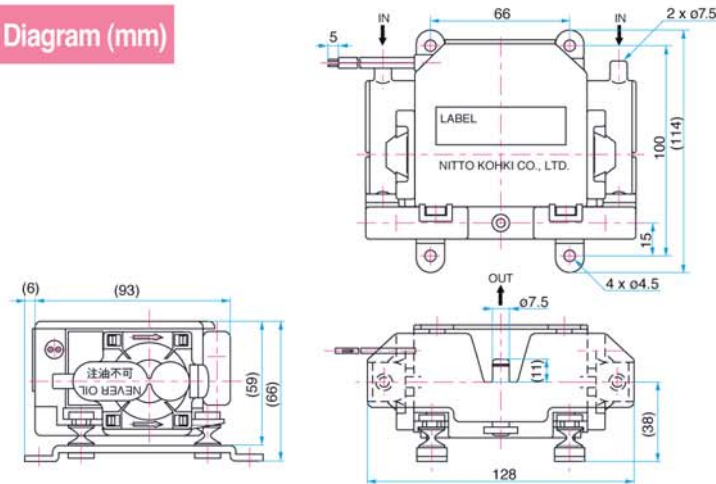

# DIAPHRAGM PUMP

## DIAPHRAGM PUMP



# vc0101E Blower Type

### Airflow & Power Consumption

### Specifications

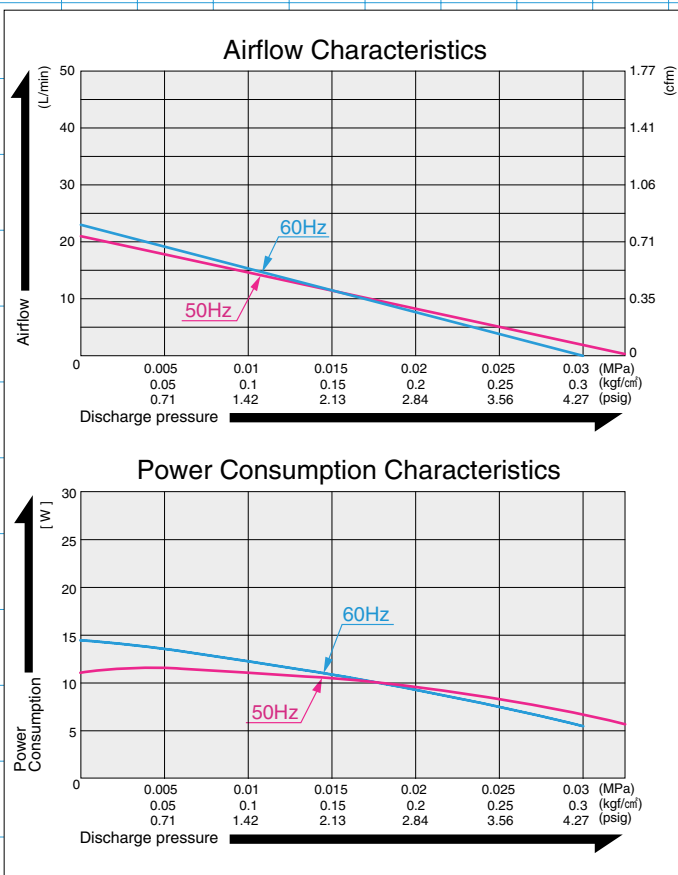

VC0101E	(SI)	(EURO)	(U.S.A.)
Rated Pressure	0.01 MPa (0.1 kgf/cm <sup>2</sup> )	0.1 bar	1.42 psig
Rated Airflow	15 L/min		0.53 cfm
Rated Voltage	120 V AC <sup>※1</sup> or 230 V AC		
Maximum Pressure	0.02 MPa (0.2 kgf/cm <sup>2</sup> )	0.2 bar	2.84 psig
Power Consumption	11.5W		
Rated Frequency	60 Hz or 50 Hz		
Life Expectancy	5,000 hours		
Working Pressure Range	0~0.02 MPa (0~0.2 kgf/cm <sup>2</sup> )	0~0.2 bar	0~2.84 psig
Outlet (Inlet)	7.5 mm O.D. hose nipple		
Duty Cycle	Continuous		
Coil Insulation Class	E or its equivalent (JETL)		
Mounting Dimensions	66 mm(L) x 100 mm(W)	2-19/32"(L) x 3-15/16"(W)	
Gross Weight	0.82 kg	1.8 Lbs.	
Leadwire Length	300 mm	11-13/16"	

※1: 120V AC UL version is unavailable.  
Please read the page of "How to Use This Catalog" first for correct use of compressors and pumps.

### Application Examples

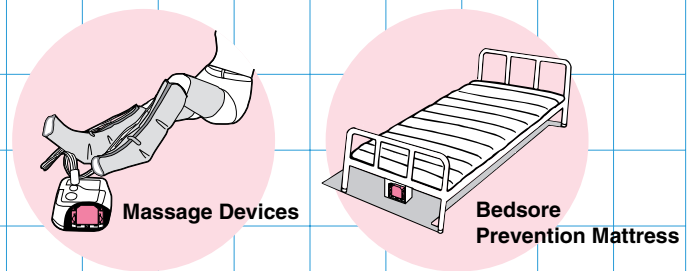

### Sketch Drawing and Mounting Dimensions Diagram (mm)

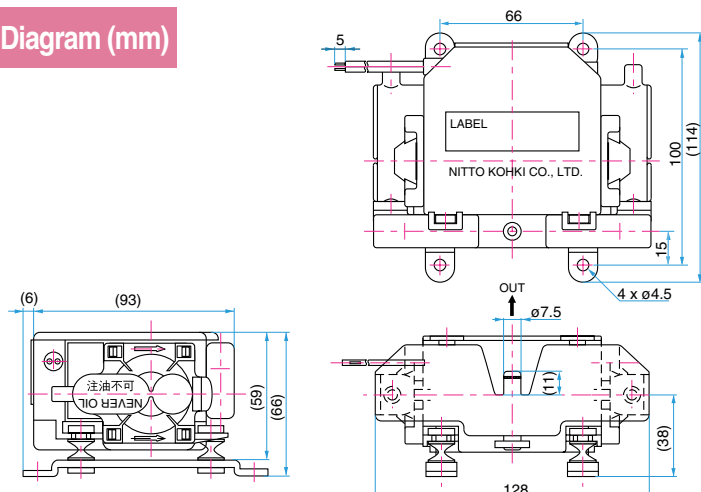

# DIAPHRAGM PUMP

## DIAPHRAGM PUMP



# vc0201 Dual Type

### Airflow & Power Consumption

### Specifications

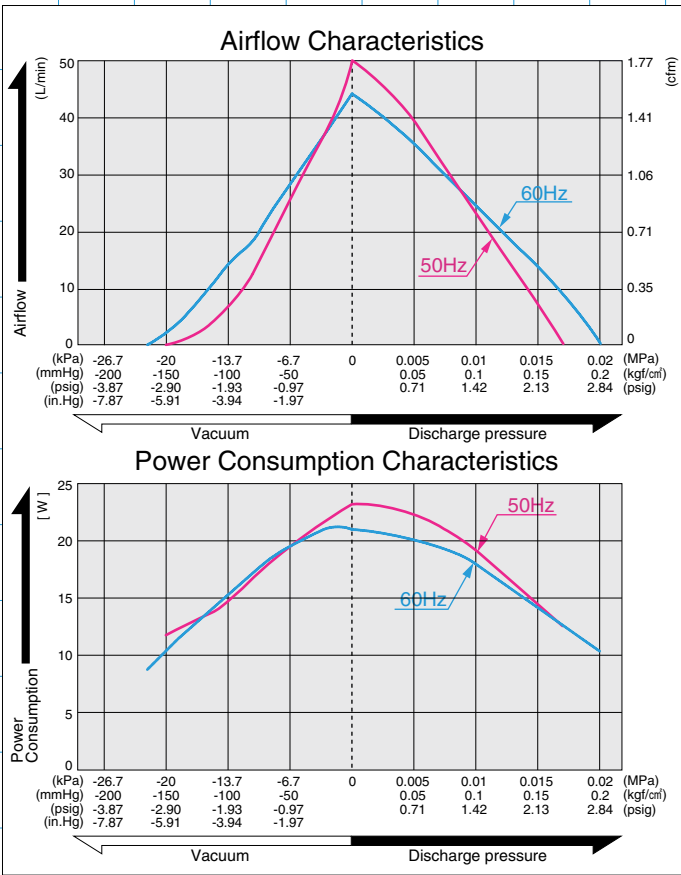

	(SI)	(EURO)	(U.S.A.)
Rated Pressure	0.01 MPa {0.1 kgf/cm <sup>2</sup> }	0.1 bar	1.42 psig
Rated Airflow	20 L/min		0.71 cfm
Rated Voltage	120 V AC or 230 V AC		
Maximum Pressure	0.018 MPa (0.18 kgf/cm <sup>2</sup> )	0.18 bar	2.56 psig
Max. vacuum	-18.7 kPa (-140 mmHg)	-187 mbar	-5.5 in.Hg
Power Consumption	18 W or 19 W		
Rated Frequency	60 Hz or 50 Hz		
Working Pressure Range	-18.7kPa~0.018 MPa	-187mbar~0.18 bar	-5.5 in.Hg ~ 2.56 psig
Life Expectancy	10,000 hours		
Outlet (or Inlet)	8.5 mm O.D. hose nipple		
Duty Cycle	Continuous		
Coil Insulation Class	A for 120V & B for 230V or its equivalent		
Mounting Dimensions	100 (L) x 85 (W) mm	3-15/16" (L) x 3-3/8" (W)	
Gross Weight	1.8 kg		4 Lbs.
Leadwire Length	200 mm		7-7/8"

Please read the page of "How to Use This Catalog" first for correct use of compressors and pumps.

### Application Examples

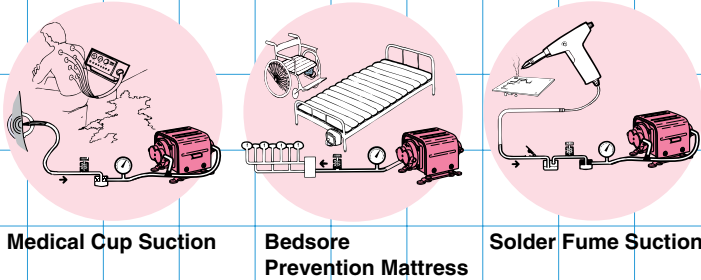

### Sketch Drawing and Mounting Dimensions Diagram (mm)

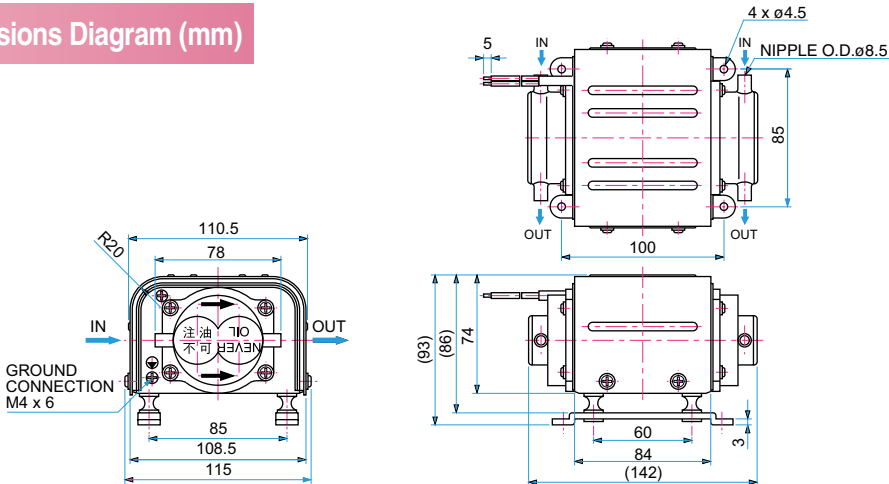

# DIAPHRAGM PUMP

## DIAPHRAGM PUMP



# vc0201 Blower Type

### Airflow & Power Consumption

### Specifications

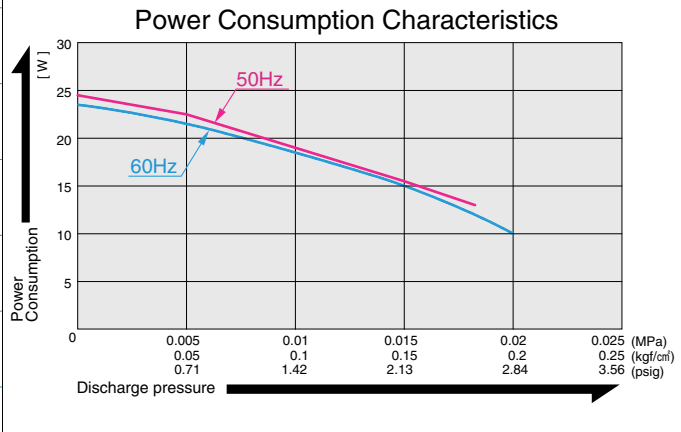
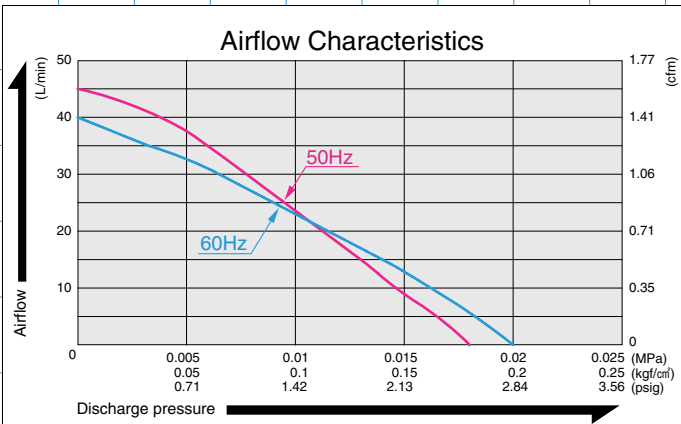

	(SI)	(EURO)	(U.S.A.)
Rated Pressure	0.01 MPa (0.1 kgf/cm <sup>2</sup> )	0.1 bar	1.42 psig
Rated Airflow	20 L/min		0.71 cfm
Rated Voltage	120 V AC or 230 V AC		
Maximum Pressure	0.018 MPa (0.18 kgf/cm <sup>2</sup> )	0.18 bar	2.56 psig
Power Consumption	18 W or 19 W		
Rated Frequency	60 Hz or 50 Hz		
Working Pressure Range	0~0.018 MPa (0~0.18 kgf/cm <sup>2</sup> )	0 ~ 0.18 bar	0 ~ 2.56 psig
Life Expectancy	10,000 hours		
Outlet (or Inlet)	8.5 mm O.D. hose nipple		
Duty Cycle	Continuous		
Coil Insulation Class	A for 120V & B for 230V or its equivalent		
Mounting Dimensions	100 (L) x 85 (mm)	3-15/16" (L) x 3-3/8" (W)	
Gross Weight	1.8 kg	4 Lbs.	
Leadwire Length	200 mm	7-7/8"	

Please read the page of "How to Use This Catalog" first for correct use of compressors and pumps.

### Application Examples

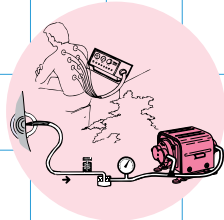

Medical Cup Suction

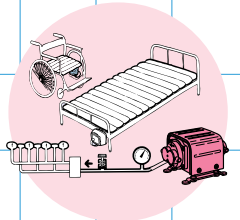

Bedsores Prevention Mattress

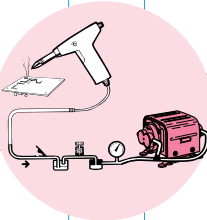

Solder Fume Suction

### Sketch Drawing and Mounting Dimensions Diagram (mm)

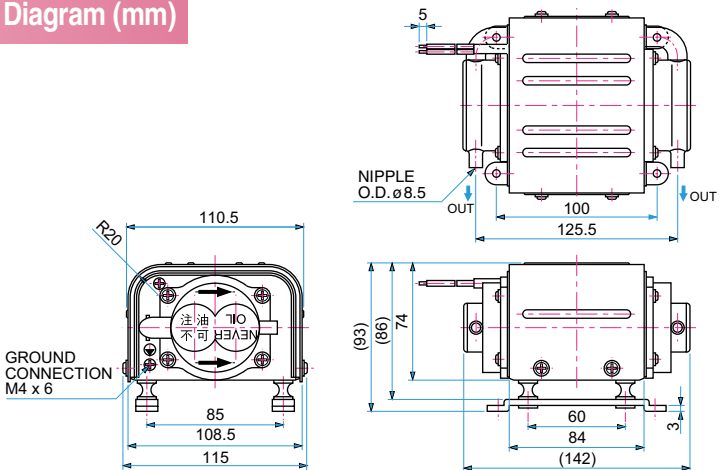

# DIAPHRAGM PUMP

## DIAPHRAGM PUMP



# vc0301 Dual Type

### Airflow & Power Consumption

### Specifications

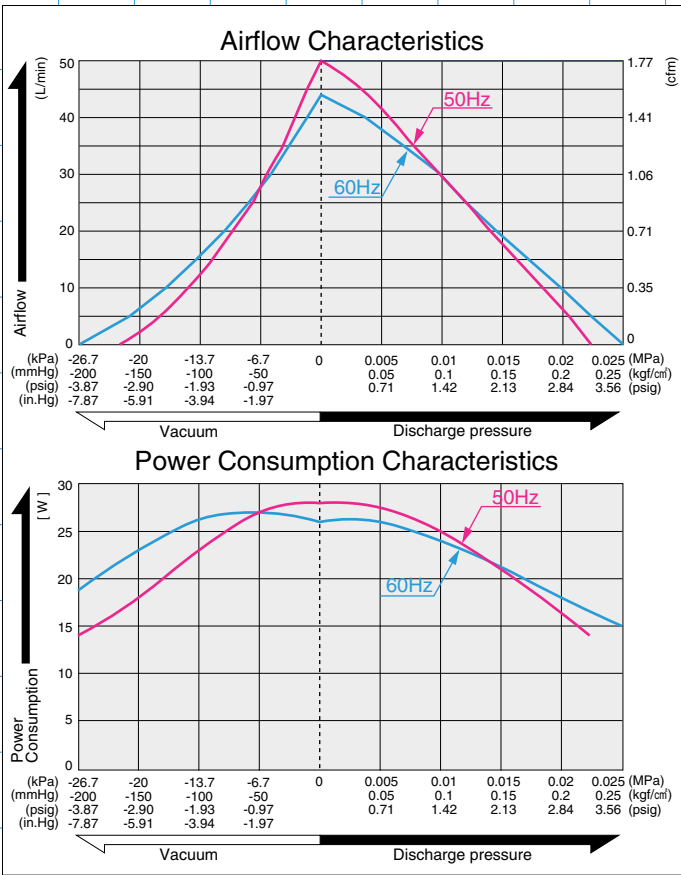

	(SI)	(EURO)	(U.S.A.)
Rated Pressure	0.01 MPa {0.1 kgf/cm <sup>2</sup> }	0.1 bar	1.42 psig
Rated Airflow 0301	25 L/min		0.88 cfm
Rated Voltage	120 V AC or 230 V AC		
Maximum Pressure	0.02 MPa {0.2 kgf/cm <sup>2</sup> }	0.2 bar	2.84 psig
Max. vacuum	-21.3 kPa {-160 mmHg}	-213 mbar	-6.3 in.Hg
Power Consumption	24 W or 25 W		
Rated Frequency	60 Hz or 50 Hz		
Working Pressure Range	-21.3kPa~0.02 MPa {-160mmHg~0.2 kgf/cm <sup>2</sup> }	-213 mbar ~ 0.2 bar	-6.3 in.Hg ~ 2.84 psig
Life Expectancy	10,000 hours		
Outlet (or Inlet)	8.5 mm O.D. hose nipple		
Duty Cycle	Continuous		
Coil Insulation Class	A for 120V & B for 230V or its equivalent		
Mounting Dimensions	100 (L) x 85 (W) mm	3-15/16" (L) x 3-3/8" (W)	
Gross Weight	1.8 kg		4 Lbs.
Leadwire Length	200 mm		

Please read the page of "How to Use This Catalog" first for correct use of compressors and pumps.

### Application Examples

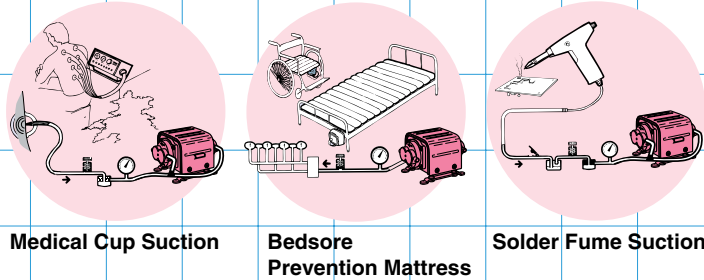

### Sketch Drawing and Mounting Dimensions Diagram (mm)

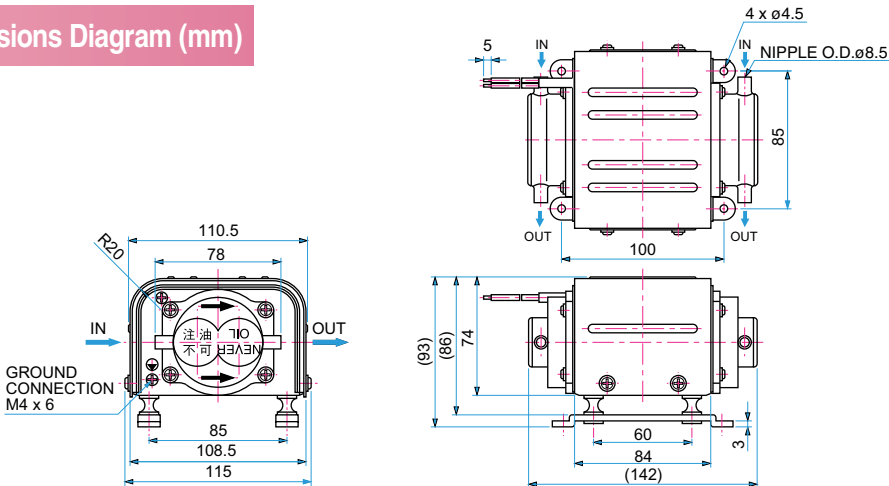

# DIAPHRAGM PUMP

## DIAPHRAGM PUMP



# vc0301 Blower Type

### Airflow & Power Consumption

### Specifications

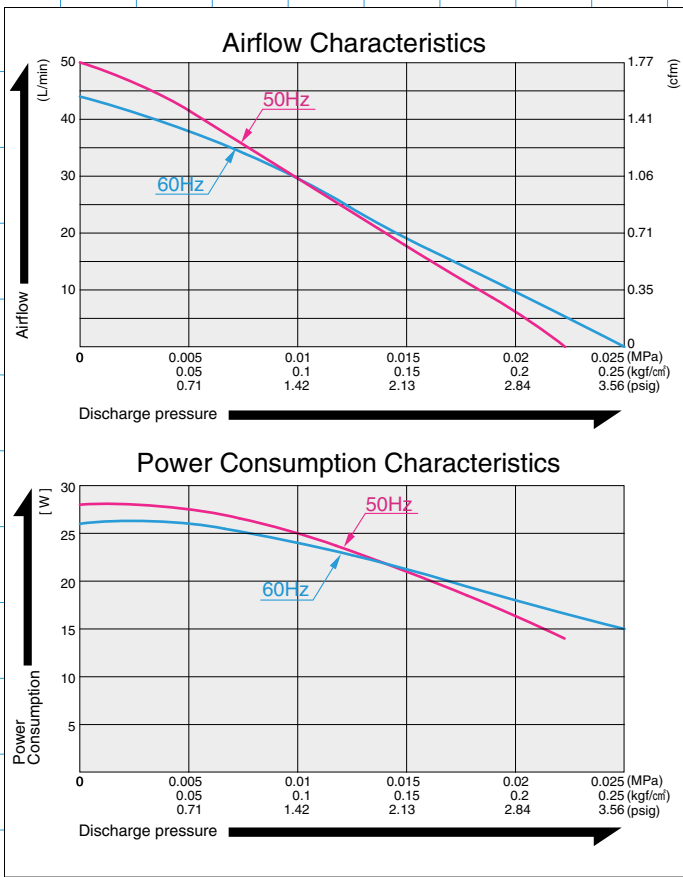

	(SI)	(EURO)	(U.S.A.)
Rated Pressure	0.01 MPa (0.1 kgf/cm <sup>2</sup> )	0.1 bar	1.42 psig
Rated Airflow VC0301	25 L/min	0.88 cfm	
Rated Voltage	120 V AC or 230 V AC		
Maximum Pressure	0.02 MPa (0.2 kgf/cm <sup>2</sup> )	0.2 bar	2.84 psig
Power Consumption	24 W or 25 W		
Rated Frequency	60 Hz or 50 Hz		
Working Pressure Range	-21.3kPa~0.02 MPa (-160mmHg~0.2 kgf/cm <sup>2</sup> )	-213 mbar ~ 0.2 bar	-6.3 in.Hg ~ 2.84 psig
Life Expectancy	10,000 hours		
Outlet (or Inlet)	8.5 mm O.D. hose nipple		
Duty Cycle	Continuous		
Coil Insulation Class	A for 120V & B for 230V or its equivalent		
Mounting Dimensions	100 (L) x 85 (W) mm	3-15/16" (L) x 3-3/8" (W)	
Gross Weight	1.8 kg		4 Lbs.
Leadwire Length	200 mm		

Please read the page of "How to Use This Catalog" first for correct use of compressors and pumps.

### Application Examples

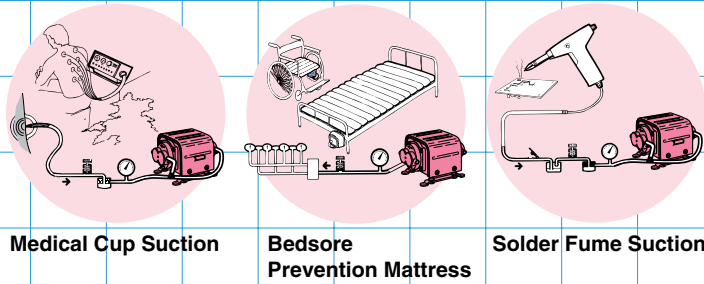

### Sketch Drawing and Mounting Dimensions Diagram (mm)

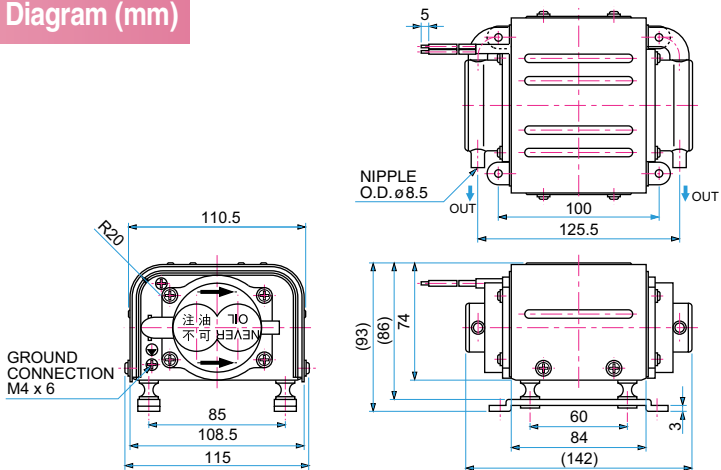

# DIAPHRAGM PUMP

## DIAPHRAGM PUMP

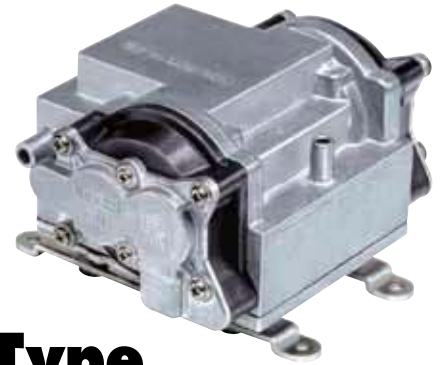

# vc0201B Dual Type

### Airflow & Power Consumption

### Specifications

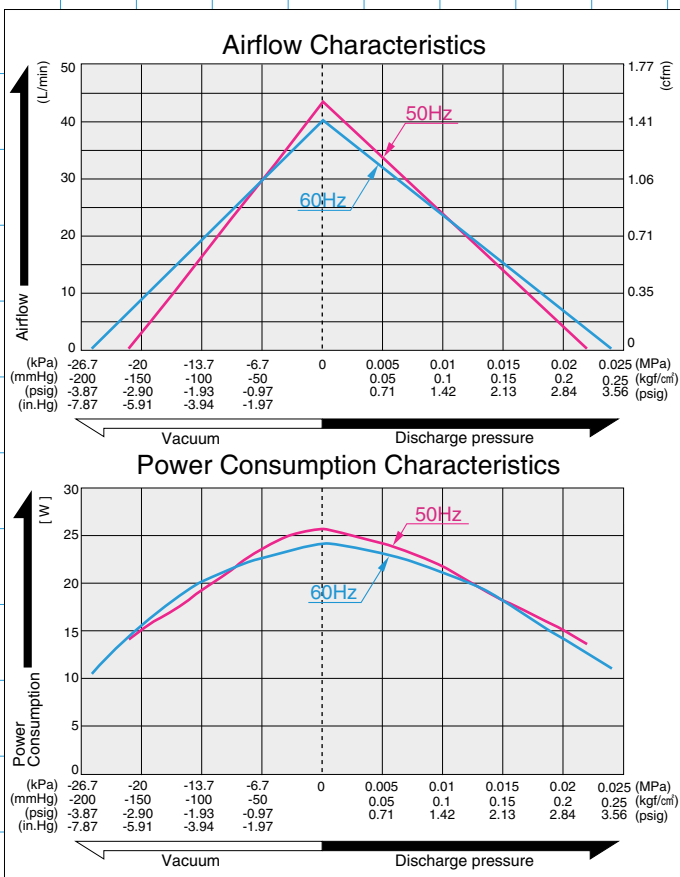

	(SI)	(EURO)	(U.S.A.)
Rated Pressure	0.01 MPa (0.1 kgf/cm <sup>2</sup> )	0.1 bar	1.42 psig
Rated Airflow	20 L/min		0.71 cfm
Rated Voltage	120 V AC or 230 V AC		
Maximum Pressure	0.018 MPa (0.18 kgf/cm <sup>2</sup> )	0.18 bar	2.56 psig
Max. vacuum	-18.7 kPa (-140 mmHg)	-187 mbar	-5.5 in.Hg
Power Consumption	21 W		
Rated Frequency	60 Hz or 50 Hz		
Working Pressure Range	-18.7kPa~0.018 MPa {-140 mmHg~0.18 kgf/cm <sup>2</sup> }	-187 mbar ~ 0.18 bar	-5.5 in.Hg ~ 2.56 psig
Life Expectancy	10,000 hours		
Inlet	10.5 mm O.D. hose nipple		
Outlet	8.5 mm O.D. hose nipple		
Duty Cycle	Continuous		
Coil Insulation Class	E or its equivalent (JETL) and A for UL		
Mounting Dimensions	125 (L) x56 (W) mm		4-15/16" (L) x 2-13/64" (W)
Gross Weight	1.7 kg		3.7 Lbs.
Leadwire Length	300 mm		11-13/16"

Please read the page of "How to Use This Catalog" first for correct use of compressors and pumps.

### Application Examples

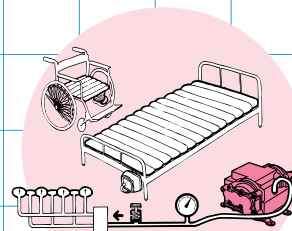

Bedsores Prevention Mattress

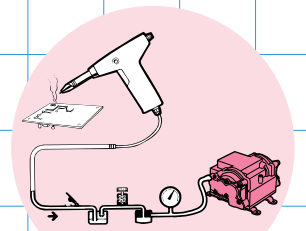

Solder Fume Suction

### Sketch Drawing and Mounting Dimensions Diagram (mm)

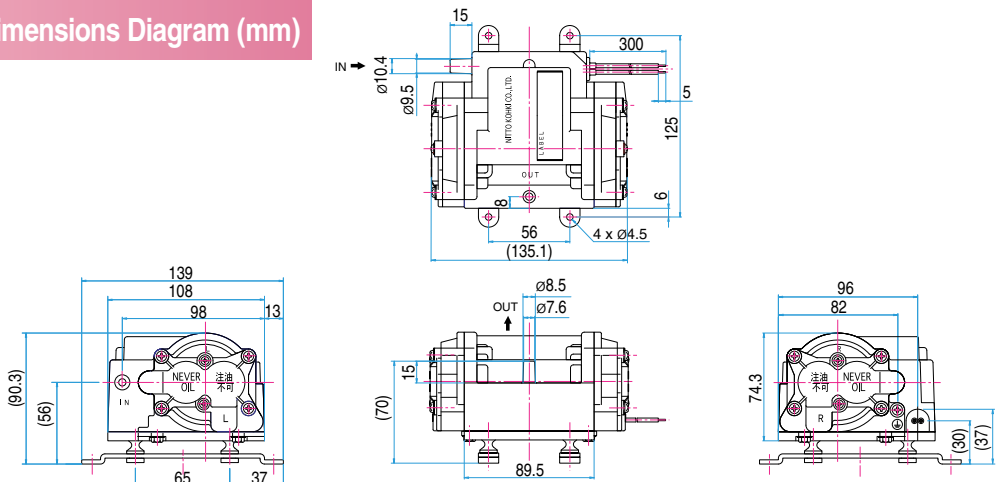



# DIAPHRAGM PUMP

## DIAPHRAGM PUMP

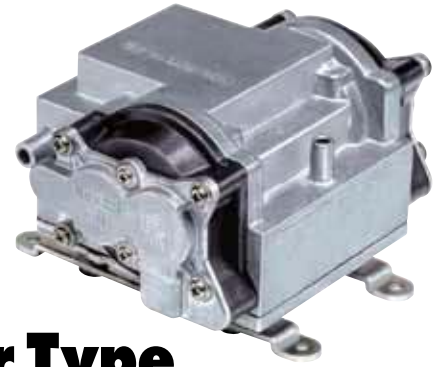

# vc0201B Blower Type

### Airflow & Power Consumption

### Specifications

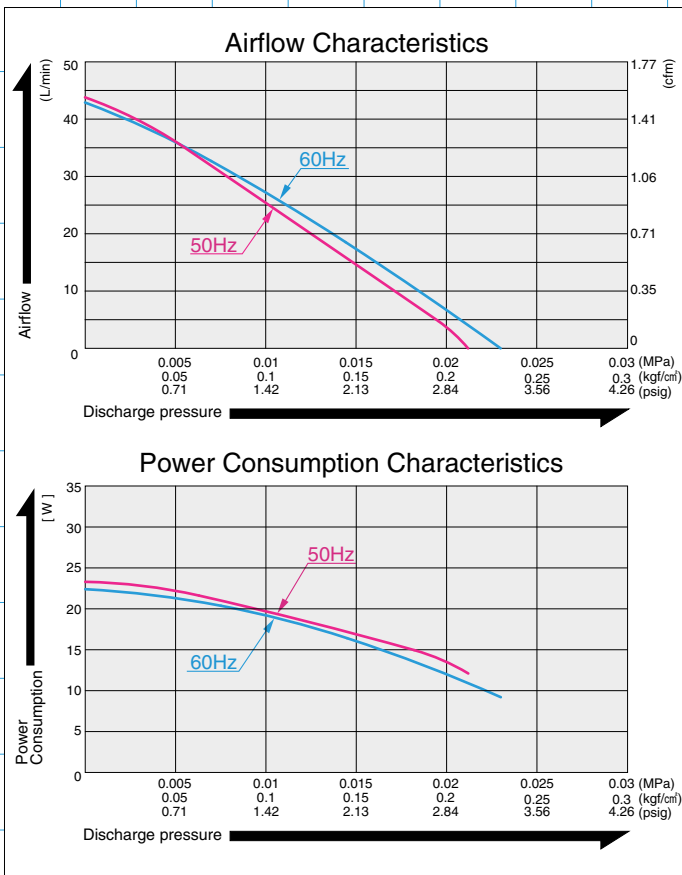

	(SI)	(EURO)	(U.S.A.)
Rated Pressure	0.01 MPa (0.1 kgf/cm <sup>2</sup> )	0.1 bar	1.42 psig
Rated Airflow	20 L/min		0.71 cfm
Rated Voltage	120 V AC or 230 V AC		
Maximum Pressure	0.018 MPa (0.18 kgf/cm <sup>2</sup> )	0.18 bar	2.56 psig
Power Consumption	21 W		
Rated Frequency	60 Hz or 50 Hz		
Working Pressure Range	0 ~ 0.018 MPa (0 ~ 0.18 kgf/cm <sup>2</sup> )	0 ~ 0.18 bar	0 ~ 2.56 psig
Life Expectancy	10,000 hours		
Outlet	8.5 mm O.D. hose nipple		
Duty Cycle	Continuous		
Coil Insulation Class	E or its equivalent (JETL) and A for UL		
Mounting Dimensions	125 (L) x 56 (W) mm	4-15/16" (L) x 2-13/64" (W)	
Gross Weight	1.7 kg		3.7 Lbs.
Leadwire Length	300 mm		11-13/16"

Please read the page of "How to Use This Catalog" first for correct use of compressors and pumps.

### Application Examples



### Sketch Drawing and Mounting Dimensions Diagram (mm)

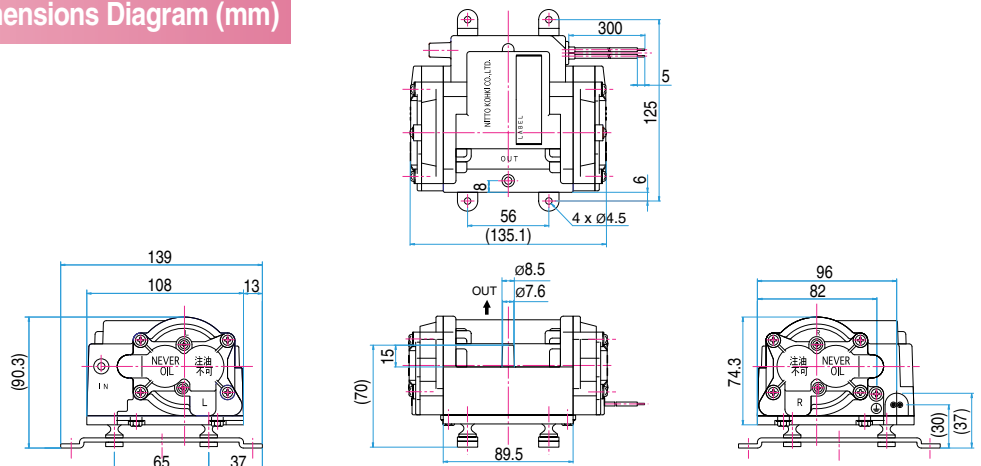

# DIAPHRAGM PUMP

## DIAPHRAGM PUMP



# vc0301B Dual Type

### Airflow & Power Consumption

### Specifications

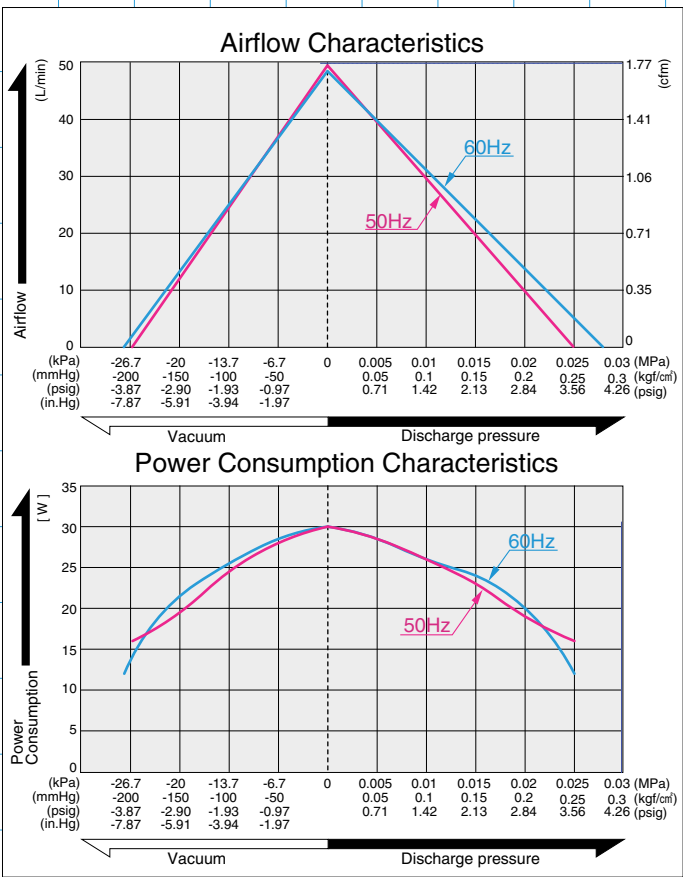

	(SI)	(EURO)	(U.S.A.)
Rated Pressure	0.01 MPa (0.1 kgf/cm <sup>2</sup> )	0.1 bar	1.42 psig
Rated Airflow	25 L/min		0.88 cfm
Rated Voltage	120 V AC or 230 V AC		
Maximum Pressure	0.02 MPa (0.2 kgf/cm <sup>2</sup> )	0.2 bar	2.84 psig
Max. vacuum	-21.3 kPa (-160 mmHg)	-213 mbar	-6.3 in.Hg
Power Consumption	27 W		
Rated Frequency	60 Hz or 50 Hz		
Working Pressure Range	-21.3kPa~0.02 MPa {-160 mmHg~0.2 kgf/cm <sup>2</sup> }	-213 mbar ~ 0.2 bar	-6.3 in.Hg ~ 2.84 psig
Life Expectancy	10,000 hours		
Inlet	10.5 mm O.D. hose nipple		
Outlet	8.5 mm O.D. hose nipple		
Duty Cycle	Continuous		
Coil Insulation Class	B or its equivalent		
Mounting Dimensions	125 (L) x56 (W) mm	4-15/16" (L) x 2-13/64" (W)	
Gross Weight	1.7 kg	3.7 Lbs.	
Leadwire Length	300 mm	11-13/16"	

Please read the page of "How to Use This Catalog" first for correct use of compressors and pumps.

### Application Examples

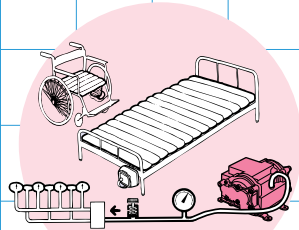

Bed sore Prevention Mattress

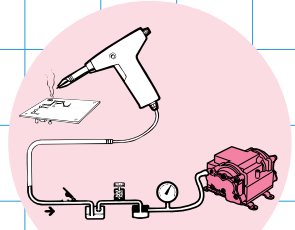

Solder Fume Suction

### Sketch Drawing and Mounting Dimensions Diagram (mm)

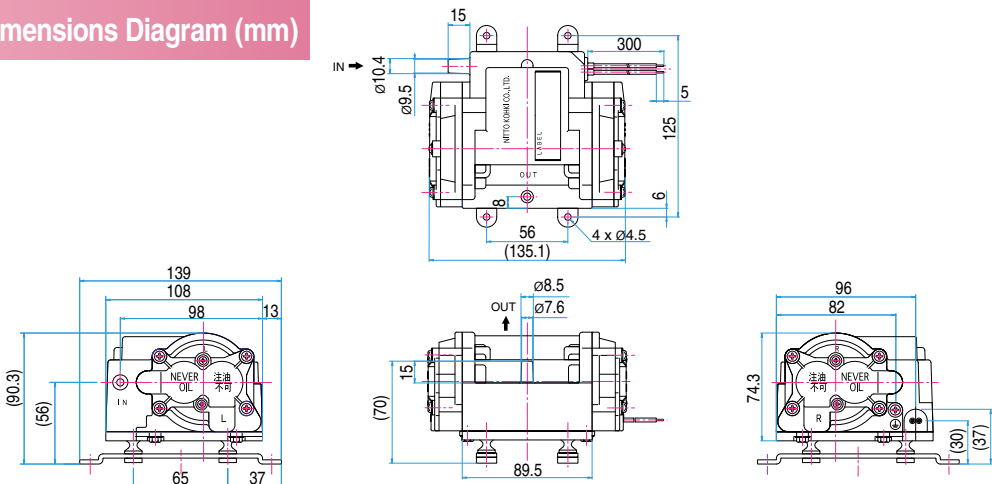

# DIAPHRAGM PUMP

## DIAPHRAGM PUMP

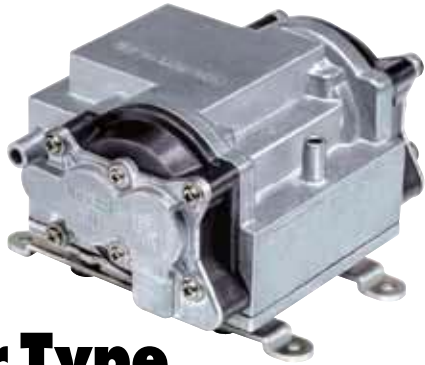

# vc0301B Blower Type

### Airflow & Power Consumption

### Specifications

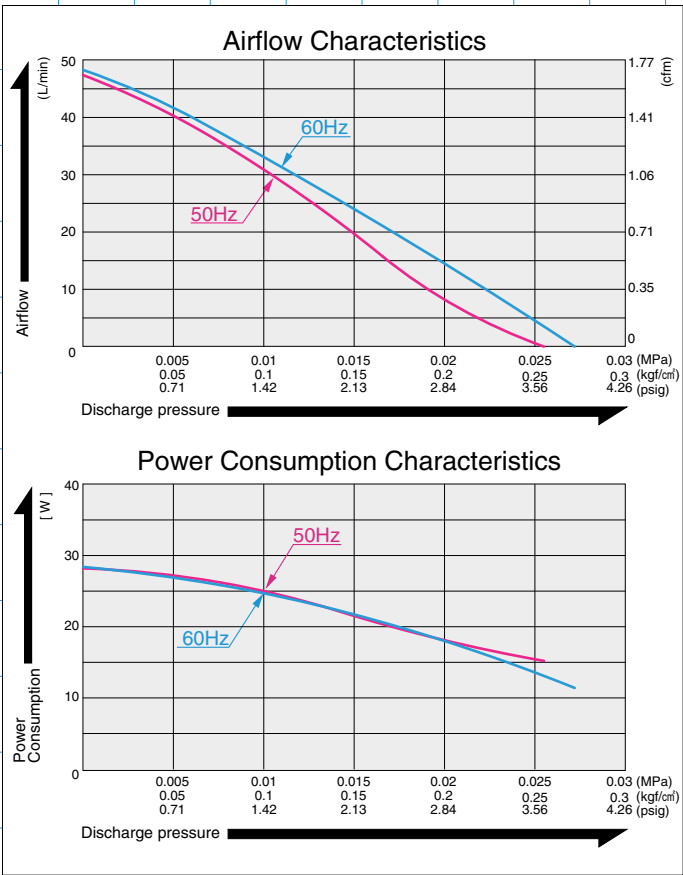

	(SI)	(EURO)	(U.S.A.)
Rated Pressure	0.01 MPa {0.1 kgf/cm <sup>2</sup> }	0.1 bar	1.42 psig
Rated Airflow	25 L/min		0.88 cfm
Rated Voltage	120 V AC or 230 V AC		
Maximum Pressure	0.02 MPa {0.2 kgf/cm <sup>2</sup> }	0.2 bar	2.84 psig
Power Consumption	27 W		
Rated Frequency	60 Hz or 50 Hz		
Working Pressure Range	0 ~ 0.02 MPa { 0 ~ 0.2 kgf/cm <sup>2</sup> }	0 ~ 0.2 bar	0 ~ 2.84 psig
Life Expectancy	10,000 hours		
Outlet	8.5 mm O.D. hose nipple		
Duty Cycle	Continuous		
Coil Insulation Class	B or its equivalent		
Mounting Dimensions	125 (L) x56 (W) mm	4-1 <sup>5</sup> / <sub>16</sub> "(L) x 2- <sup>13</sup> / <sub>64</sub> "(W)	
Gross Weight	1.7 kg		
Leadwire Length	300 mm		
	11-13/16"		

Please read the page of "How to Use This Catalog" first for correct use of compressors and pumps.

### Application Examples



### Sketch Drawing and Mounting Dimensions Diagram (mm)

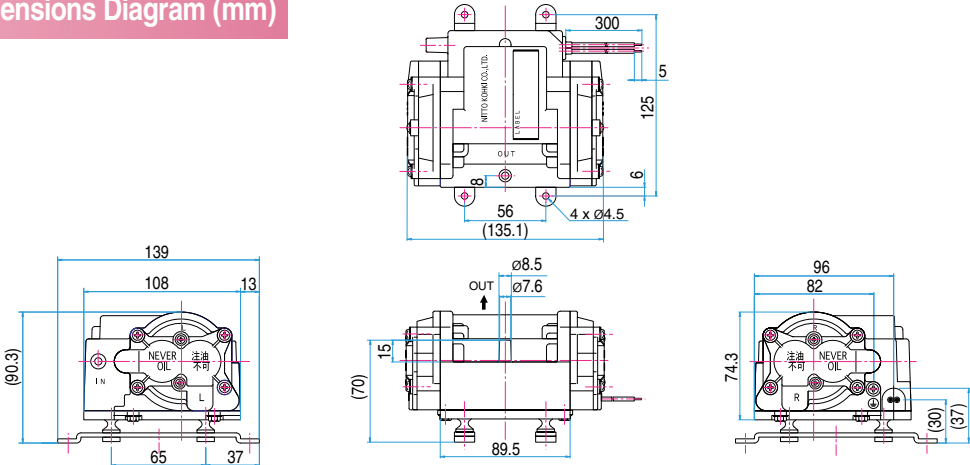





# DIAPHRAGM PUMP PISTON PUMP

# DC

## Diaphragm Pump Piston Pump

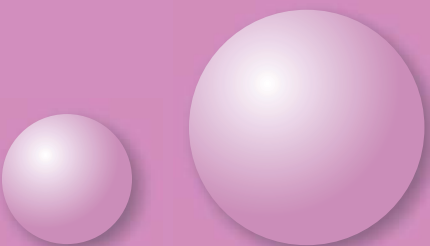

- DP0125  
P69
- DP0140  
P70
- DP0102  
P71
- DP0102S  
P72
- DP0102H-X1  
P73
- DP0102H-X2  
P74
- DP0105-X1  
P75
- DP0105-Y1  
P76
- DPA0105-X1  
P77
- DPA0105-Y1  
P78
- DP0110-X1  
P79
- DP0110-Y1  
P80
- DP0110PWM  
P81

# DC AIR PUMP

## DIAPHRAGM PUMP



# DP0125

### Airflow & Electric Current

### Specifications

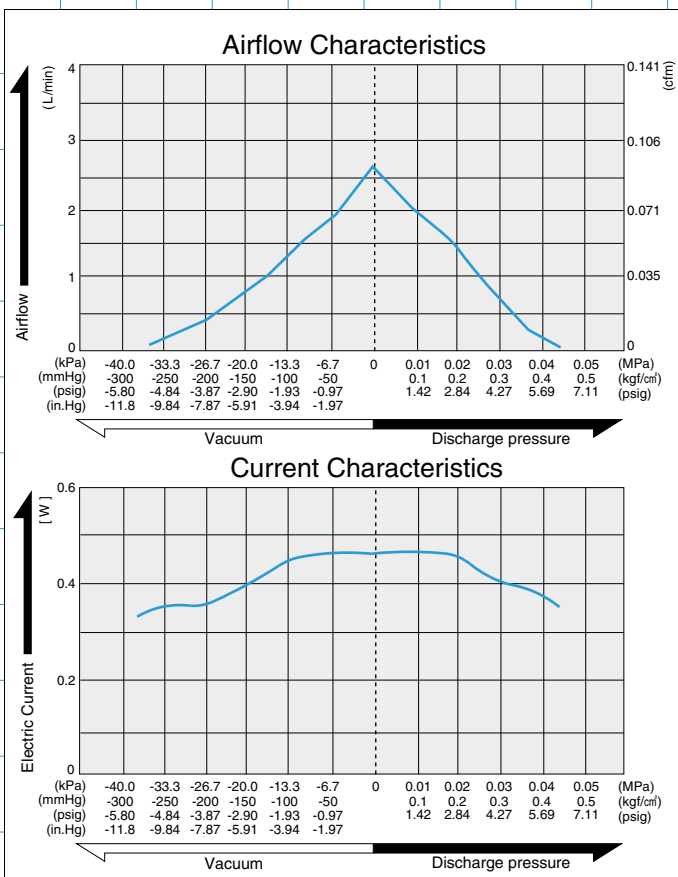

	(SI)	(EURO)	(U.S.A.)
Attainable Vacuum	-33.3 kPa (-250 mmHg)	-333 mbar	-9.84 in.Hg
Free Air Displacement	2.5 L/min		0.088 cfm
Rated Voltage	12 V DC		
Maximum Pressure	0.03 MPa (0.3 kgf/cm²)	0.3 bar	4.27 psig
Maximum Current	0.5A		
Duty Cycle	Continuous		
Life Expectancy	200 hours		
Inlet (or Outlet)	3 mm O.D. straight nipple		
Coil Insulation Class	E or its equivalent (JETL)		
Mounting Dimensions	32 mm(L) x 32.5 mm(W)	1 1/4" (L) x 1 9/32" (W)	
Gross Weight	0.08 kg	0.18 Lbs.	

Please read the page of "How to Use This Catalog" first for correct use of compressors and pumps.

### Application Examples

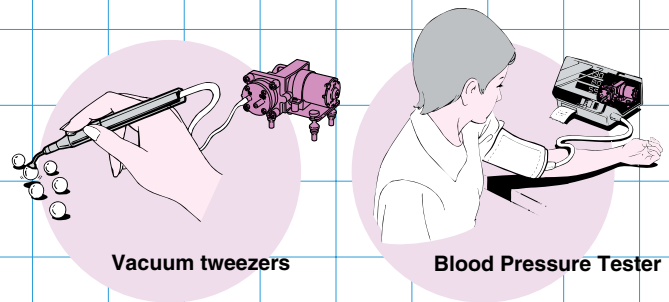

### Sketch Drawing and Mounting Dimensions Diagram (mm)

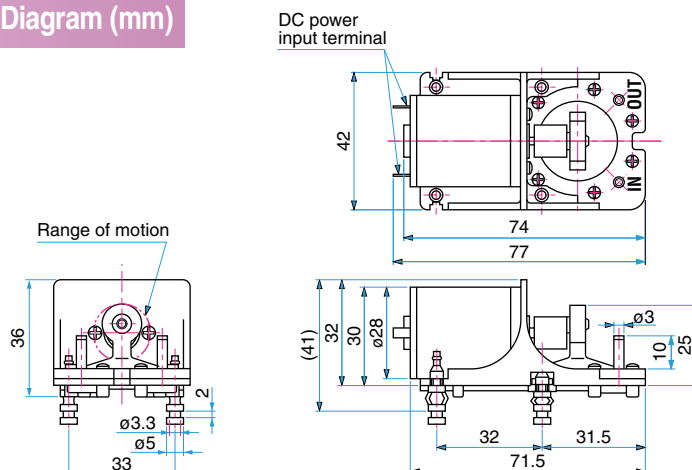



# DC AIR PUMP

## DIAPHRAGM PUMP



# DP0102

### Airflow & Electric Current

### Specifications

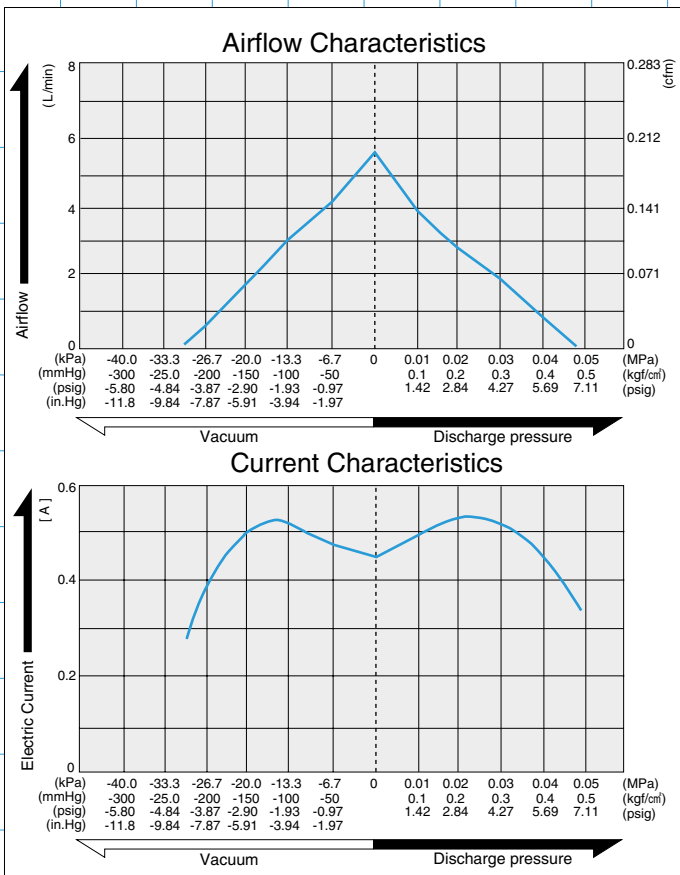

	(SI)	(EURO)	(U.S.A.)
Attainable Vacuum	-26.7 kPa (-200 mmHg)	-267 mbar	-7.87 in.Hg
Free Air Displacement	5.0 L/min		0.177 cfm
Rated Voltage	12 V DC		
Maximum Pressure	0.045 MPa(0.45kg/cm <sup>2</sup> )	0.45 bar	6.4 psig
Maximum Current	0.7 A		
Rated Operating Time	Continuous		
Working Pressure Range	-26.7kPa~-0.045 MPa (-200mmHg~-0.45kg/cm <sup>2</sup> )	-267 mbar~ -0.45 bar	-7.87 in.Hg ~ 6.4 psig
Life Expectancy	5000 hours		
Inlet and Outlet	6 mm O.D. straight nipple		
Coil Insulation Class	E or its equivalent (JETL)		
Mounting Dimensions	50 mm(L) x 30 mm(W)	1- <sup>31</sup> / <sub>32</sub> "(L) x 1- <sup>3</sup> / <sub>16</sub> "(W)	
Gross Weight	0.25 kg 0.55 Lbs.		
Leadwire Length	400 mm 15- <sup>3</sup> / <sub>4</sub> "		

Please read the page of "How to Use This Catalog" first for correct use of compressors and pumps.

### Application Examples

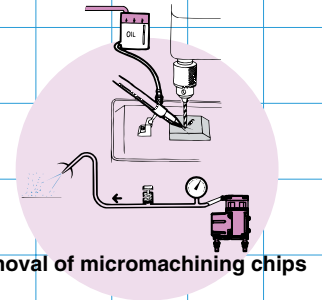
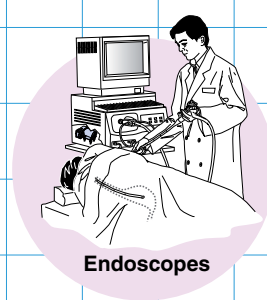

### Sketch Drawing and Mounting Dimensions Diagram (mm)

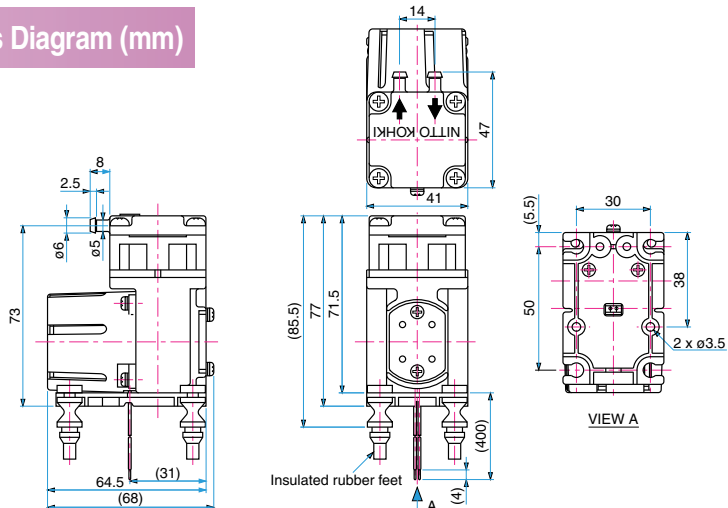





# DC AIR PUMP

## DIAPHRAGM PUMP



# DP0102H-X1 (12 V DC)

### Airflow & Electric Current

### Specifications

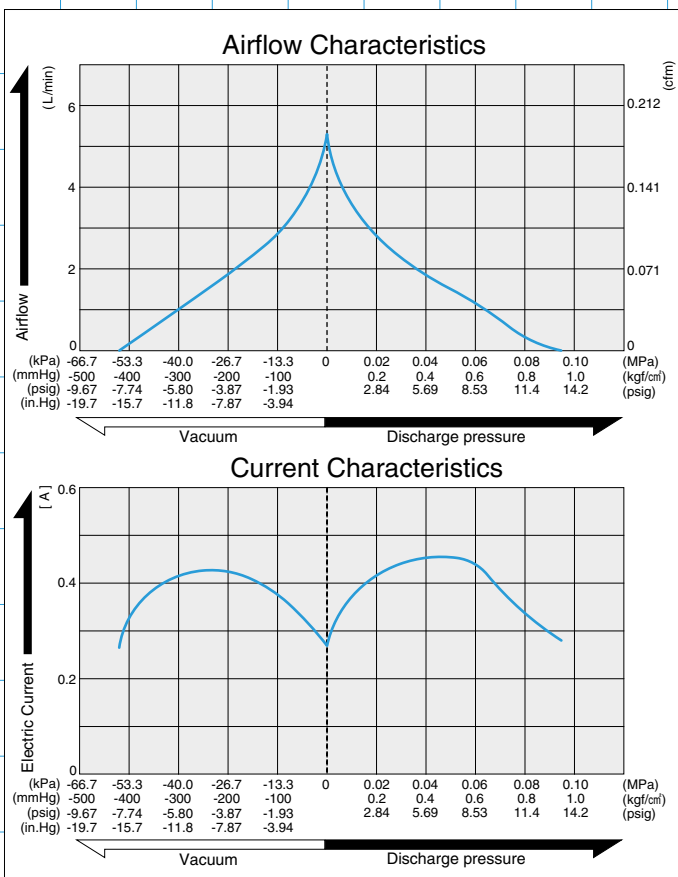

	(SI)	(EURO)	(U.S.A.)
Attainable Vacuum	-50.7 kPa (-380 mmHg)	-507 mbar	-15 in.Hg
Free Air Displacement	4.0 L/min		0.141 cfm
Rated Voltage	12 V DC		
Maximum Pressure	0.08 MPa(0.8 kg/cm <sup>2</sup> )	0.8 bar	11.4 psig
Maximum Current	0.7 A		
Rated Operating Time	Continuous		
Working Pressure Range	-50.7kPa~0.08 MPa {-380 mmHg~0.8 kg/cm <sup>2</sup> }	-507 mbar~ 0.8 bar	-15 in.Hg~ 11.4 psig
Life Expectancy	3000 hours		
Inlet and Outlet	6 mm O.D. hose nipple		
Coil Insulation Class	E or its equivalent (JETL)		
Mounting Dimensions	50 mm(L) x 30 mm(W)	1- <sup>37</sup> / <sub>32</sub> "(L) x 1- <sup>3</sup> / <sub>16</sub> "(W)	
Gross Weight	0.25 kg	0.55 Lbs.	
Leadwire Length	400 mm	15- <sup>3</sup> / <sub>16</sub> "	

Please read the page of "How to Use This Catalog" first for correct use of compressors and pumps.

### Application Examples

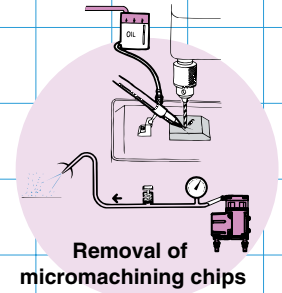
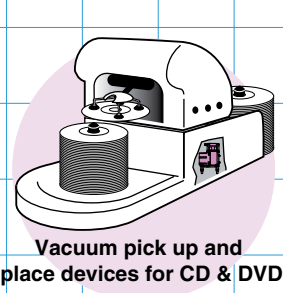

### Sketch Drawing and Mounting Dimensions Diagram (mm)

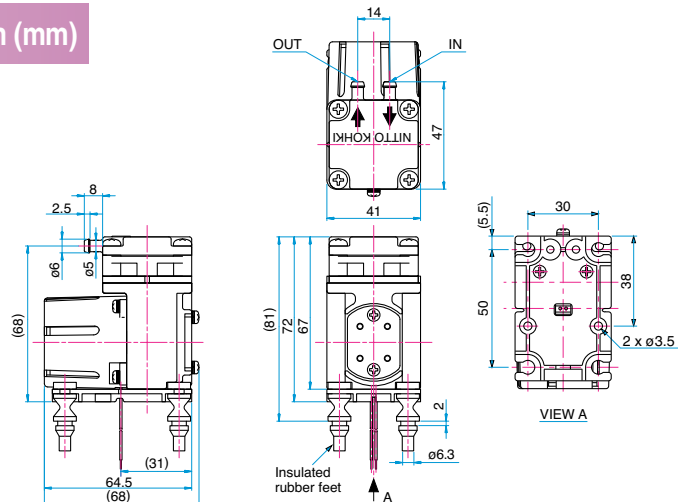

# DC AIR PUMP

## DIAPHRAGM PUMP



# DP0102H-X2 (12 V DC)

### Airflow & Electric Current

### Specifications

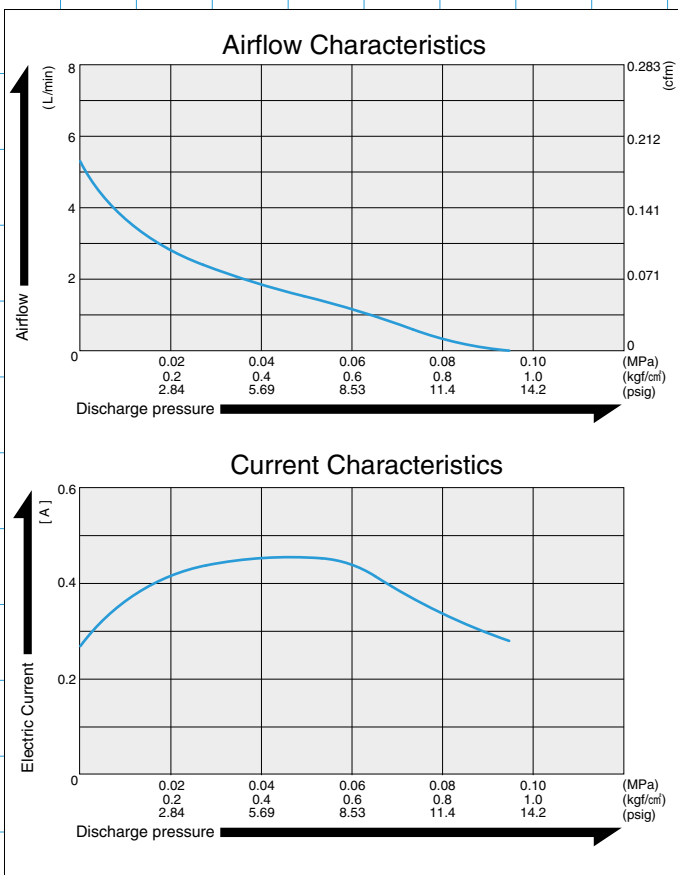

	(SI)	(EURO)	(U.S.A.)
Free Air Displacement	4.0 L/min		0.141 cfm
Rated Voltage	12 V DC		
Maximum Pressure	0.08 MPa(0.8kg/cm <sup>2</sup> )	0.8 bar	11.4 psig
Maximum Current	0.7 A		
Rated Operating Time	Continuous		
Working Pressure Range	0~0.08 MPa(0~0.8kg/cm <sup>2</sup> )	0~0.8 bar	0~11.4 psig
Life Expectancy	3000 hours		
Inlet and Outlet	6 mm O.D. hose nipple		
Coil Insulation Class	E or its equivalent (JETL)		
Mounting Dimensions	50 mm(L) x 30 mm(W)	1-3/32" (L) x 1-3/16" (W)	
Gross Weight	0.25 kg		0.55 Lbs.
Leadwire Length	400 mm		15-3/4"

Please read the page of "How to Use This Catalog" first for correct use of compressors and pumps.

### Application Examples

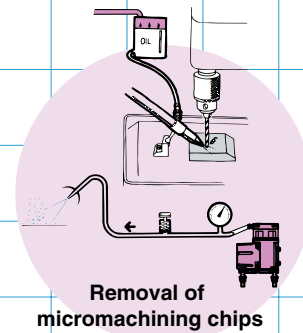

### Sketch Drawing and Mounting Dimensions Diagram (mm)

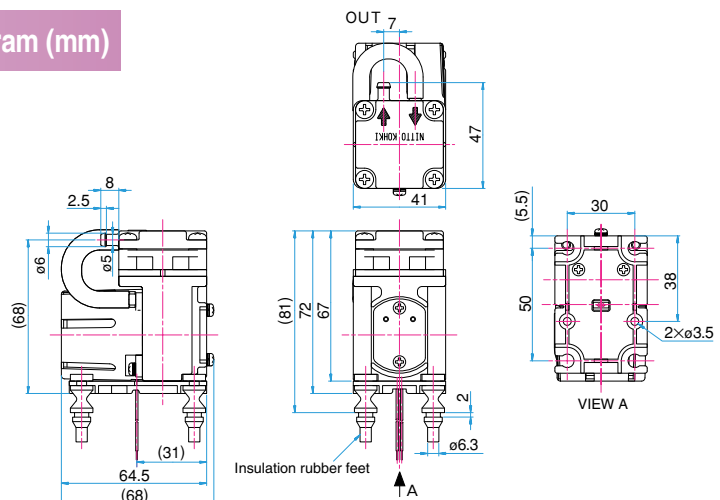

# DC AIR PUMP

## PISTON PUMP

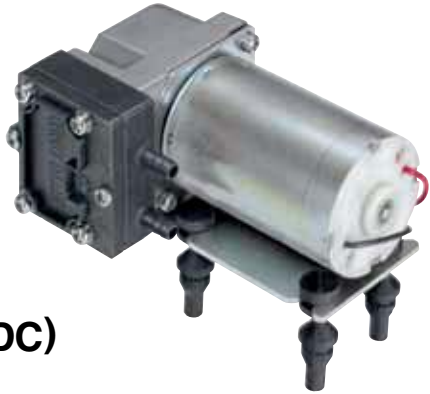

# DP0105-X1 (12 V DC)

Ask your distributor for appropriate operation of both compression and vacuum in the same one pump.

### Airflow & Electric Current

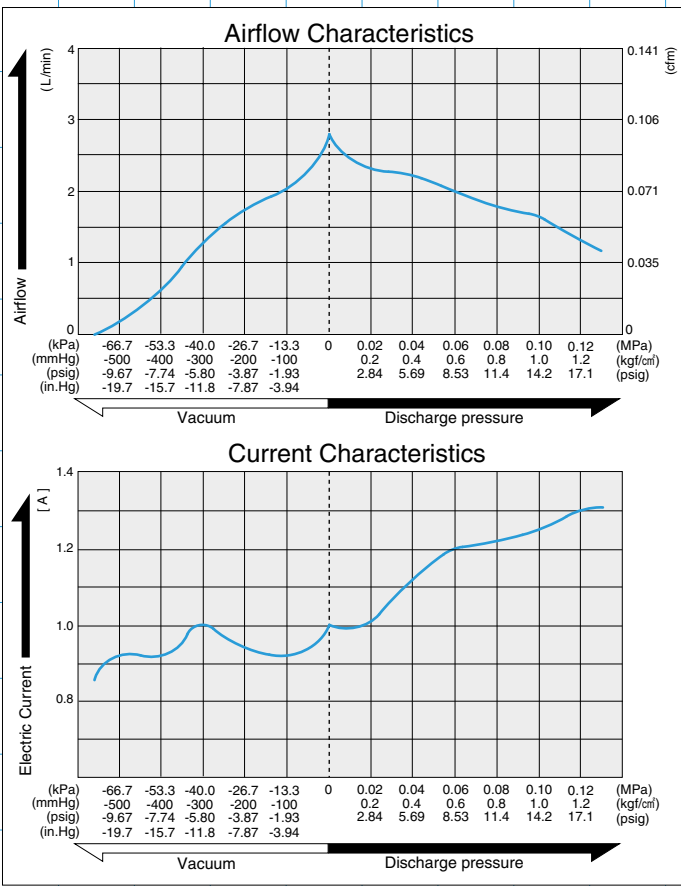

### Specifications

	(SI)	(EURO)	(U.S.A.)
Attainable Vacuum	-66.6 kPa {-500 mmHg}	-666 mbar	-19.7 in.Hg
Free Air Displacement	2.8 L/min		0.1 cfm
Rated Voltage	12 V DC		
Maximum Pressure	0.25 MPa [2.5 kgf/cm <sup>2</sup> ]	2.5 bar	35.6 psig
Maximum Current	1.9 A		
Rated Operating Time	30 minutes		
Working Pressure Range	-66.6 kPa~0.1 MPa {-500mmHg~1 kgf/cm <sup>2</sup> }	-666 mbar ~ 1 bar	-19.7 in.Hg~ 14.2 psig
Life Expectancy	1000 hours		
Inlet and Outlet	5 mm O.D. straight nipple		
Coil Insulation Class	E or its equivalent (JETL)		
Mounting Dimensions	42 mm(L) x 24.5 mm(W)	1- <sup>2</sup> / <sub>32</sub> "(L) x 1- <sup>3</sup> / <sub>32</sub> "(W)	
Gross Weight	0.36 kg	0.80 Lbs.	
Leadwire Length	360 mm	14- <sup>3</sup> / <sub>16</sub> "	

Please read the page of "How to Use This Catalog" first for correct use of compressors and pumps.

### Application Examples

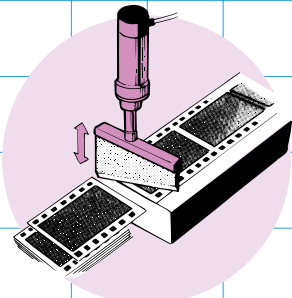

Film Cutter

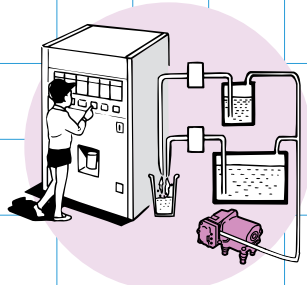

Vending Machines

### Sketch Drawing and Mounting Dimensions Diagram (mm)

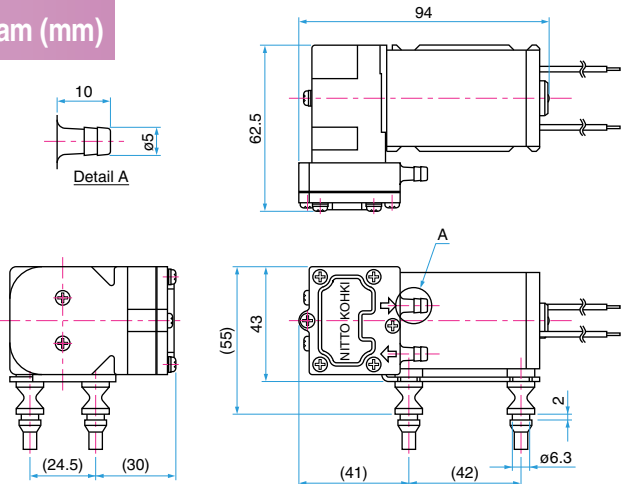



# DC AIR PUMP

## PISTON PUMP

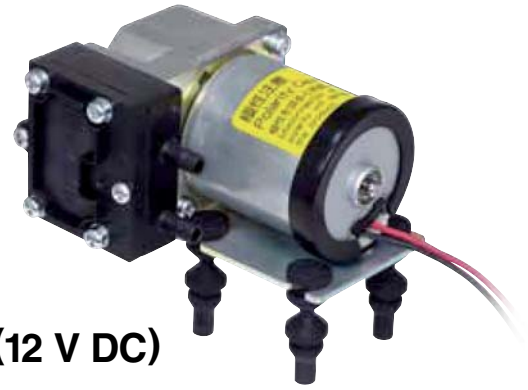

# DPA0105-X1 (12 V DC)

Ask your distributor for appropriate operation of both compression and vacuum in the same one pump.

### Airflow & Electric Current

### Specifications

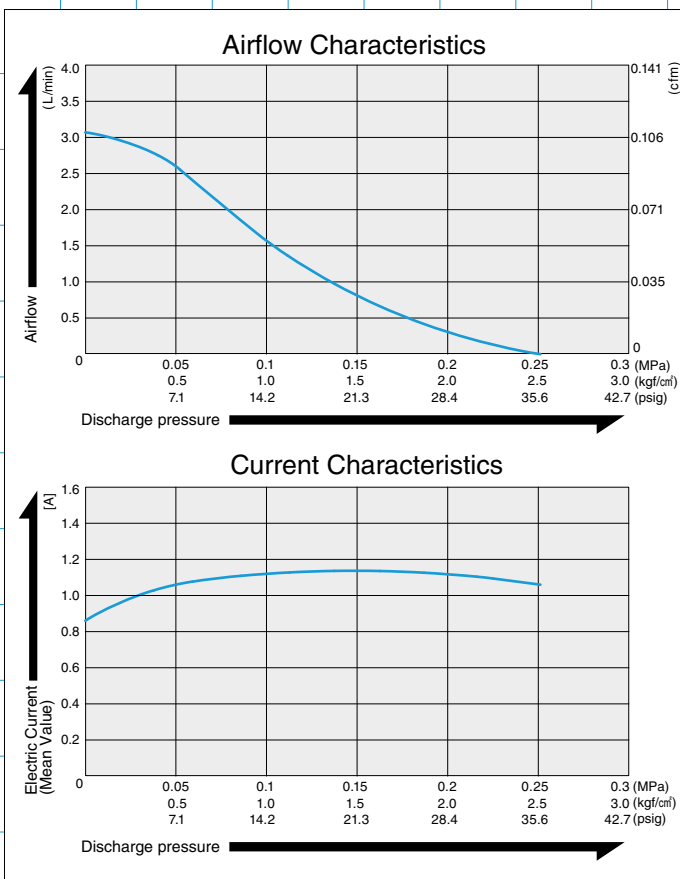

	(SI)	(EURO)	(U.S.A.)
Free Air Displacement	2.8 L/min		0.1 cfm
Rated Voltage	12 V DC		
Maximum Pressure	0.22 MPa {2.2 kgf/cm <sup>2</sup> }	2.2 bar	31.3 psig
Maximum Current	1.4 A		
Rated Operating Time	Continuous		
Working Pressure Range	0 ~ 0.1 MPa {0 ~ 1 kgf/cm <sup>2</sup> }	0 ~ 1 bar	0 ~ 14.2 psig
Life Expectancy(MTTF)	5,000 hours		
Inlet and Outlet	5 mm O.D. straight nipple		
Coil Insulation Class	A or its equivalent (JETL)		
Mounting Dimensions	50 mm(L) x 30 mm(W)	1-3/32"(L) x 1-3/16"(W)	
Gross Weight	0.3 kg		0.66 Lbs.
Leadwire Length	360 mm		14-3/16"

Please read the page of "How to Use This Catalog" first for correct use of compressors and pumps.

### Application Examples

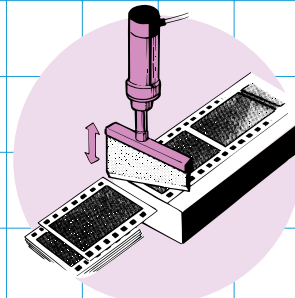

Film Cutter

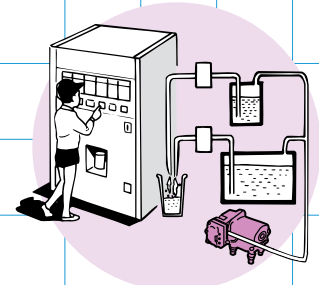

Vending Machines

### Sketch Drawing and Mounting Dimensions Diagram (mm)

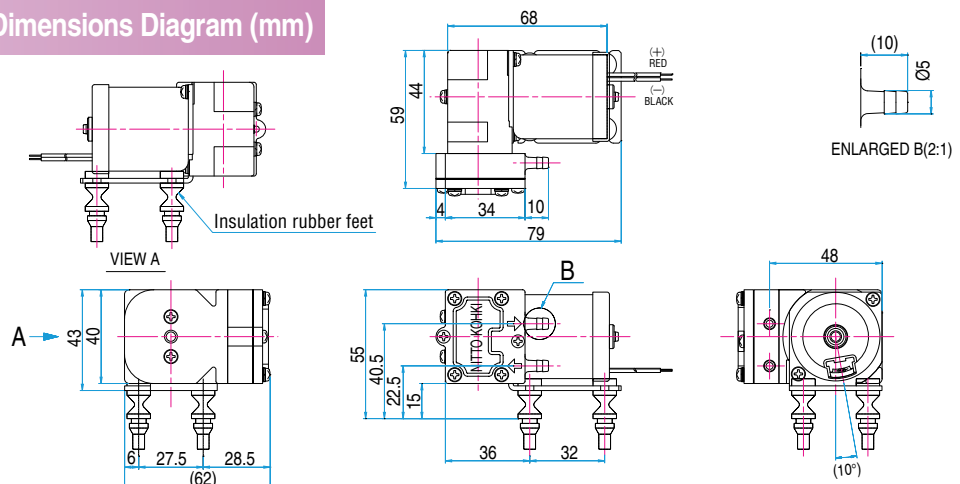

# DC AIR PUMP

## PISTON PUMP

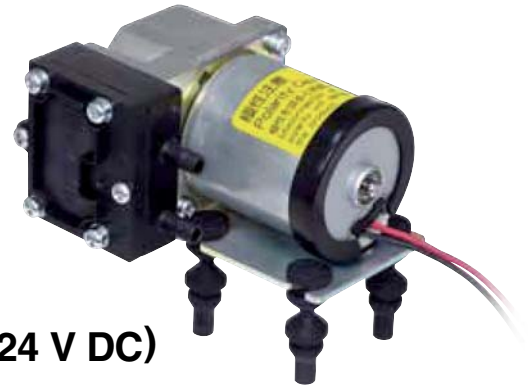

# DPA0105-Y1 (24 V DC)

Ask your distributor for appropriate operation of both compression and vacuum in the same one pump.

### Airflow & Electric Current

### Specifications

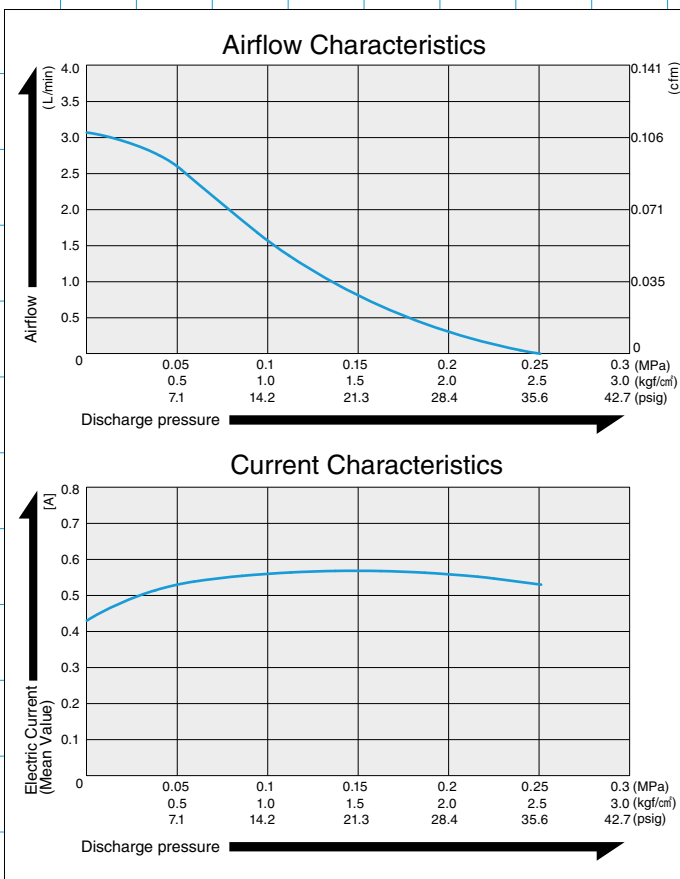

	(SI)	(EURO)	(U.S.A.)
Free Air Displacement	2.8 L/min		0.1 cfm
Rated Voltage	24 V DC		
Maximum Pressure	0.22 MPa {2.2 kgf/cm <sup>2</sup> }	2.2 bar	31.3 psig
Maximum Current	0.7 A		
Rated Operating Time	Continuous		
Working Pressure Range	0 ~ 0.1 MPa {0 ~ 1 kgf/cm <sup>2</sup> }	0 ~ 1 bar	0 ~ 14.2 psig
Life Expectancy	5,000 hours		
Inlet and Outlet	5 mm O.D. straight nipple		
Coil Insulation Class	A or its equivalent (JETL)		
Mounting Dimensions	50 mm(L) x 30 mm(W)	1- <sup>3</sup> / <sub>32</sub> "(L) x 1- <sup>3</sup> / <sub>16</sub> "(W)	
Gross Weight	0.3 kg		0.66 Lbs.
Leadwire Length	360 mm		14- <sup>3</sup> / <sub>16</sub> "

Please read the page of "How to Use This Catalog" first for correct use of compressors and pumps.

### Application Examples

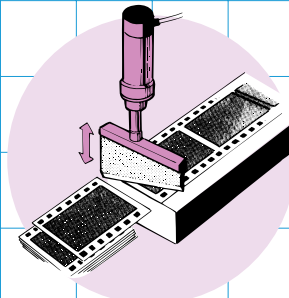

Film Cutter

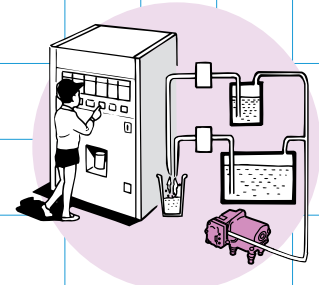

Vending Machines

### Sketch Drawing and Mounting Dimensions Diagram (mm)

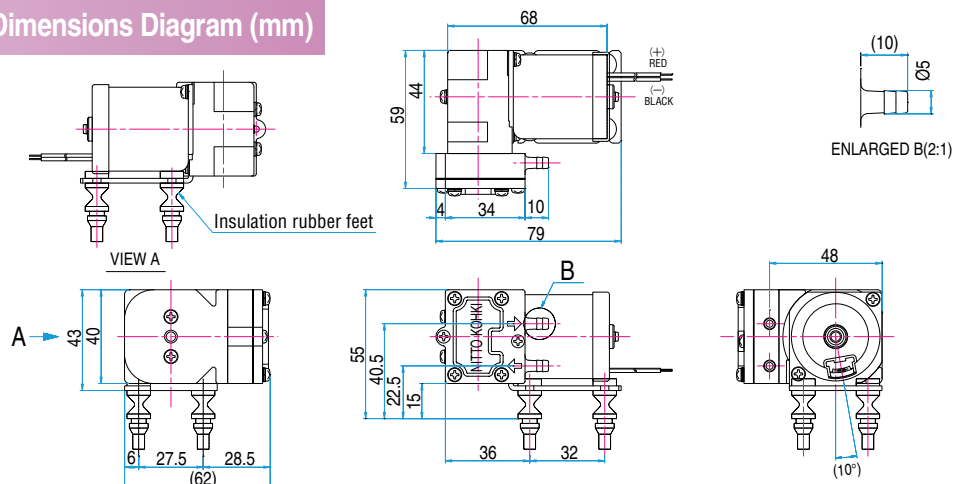

# DC AIR PUMP

## DIAPHRAGM PUMP

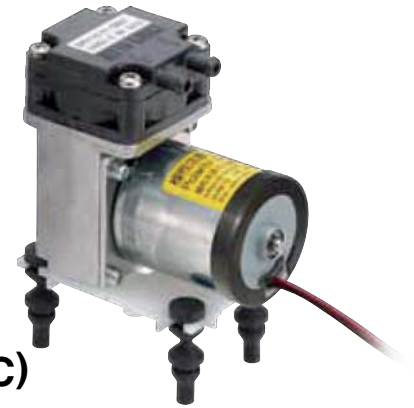

# DP0110-X1 (12 V DC)

### Airflow & Electric Current

### Specifications

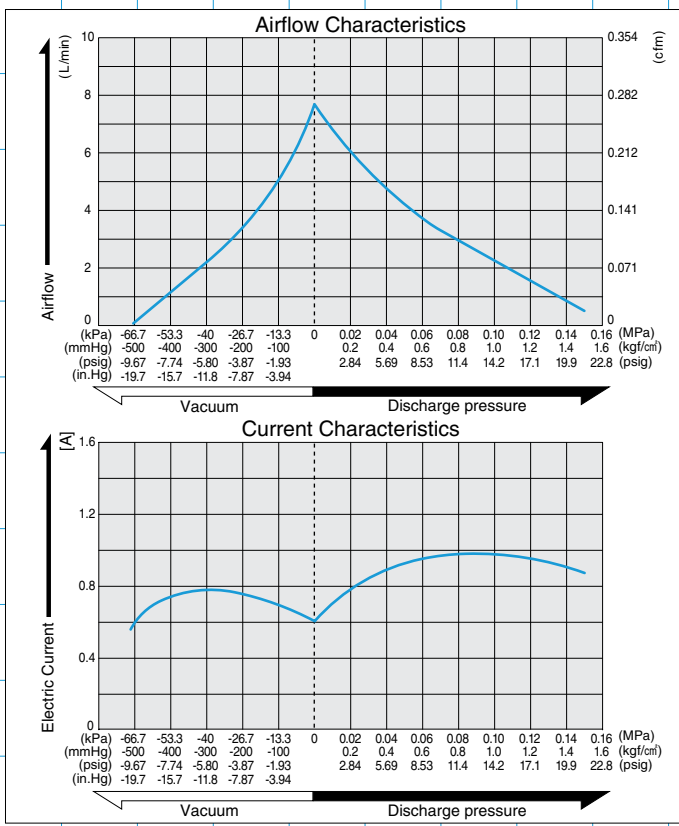

	(SI)	(EURO)	(U.S.A.)
Free Air Displacement	7.5 L/min		0.26 cfm
Rated Voltage	12 V DC		
Maximum Pressure	0.15 MPa {1.5 kgf/cm <sup>2</sup> }	1.5 bar	21.3 psig
Maximum Current	1.2 A or less		
Attainable Vacuum	-66.6kPa (-500mmHg)	-666 mbar	-19.7 in.Hg
Rated Operating Time	Continuous		
Life Expectancy	5,000 hours		
Inlet and Outlet	6 mm O.D. straight nipple		
Coil Insulation Class	A or its equivalent (JTFL)		
Mounting Dimensions	50 mm(L) x 30 mm(W)	1- <sup>31</sup> / <sub>32</sub> "(L) x 1- <sup>3</sup> / <sub>16</sub> "(W)	
Gross Weight	0.30 kg	0.66 Lbs.	
Leadwire Length	360 mm	14- <sup>3</sup> / <sub>16</sub> "	

Please read the page of "How to Use This Catalog" first for correct use of compressors and pumps.

### Application Examples

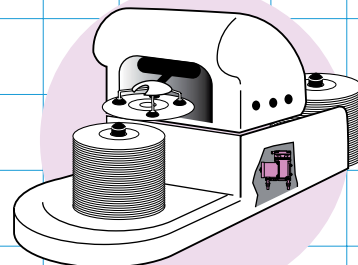

Vacuum pick up and place devices for CD & DVD

### Sketch Drawing and Mounting Dimensions Diagram (mm)

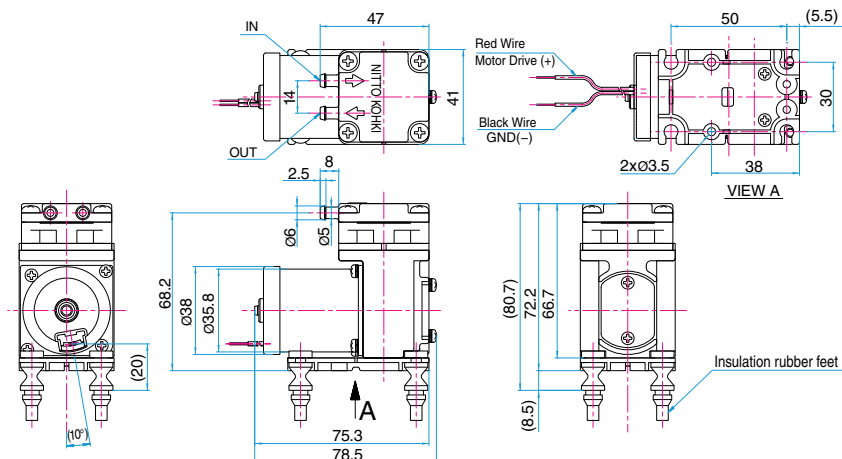



# DC AIR PUMP

## DIAPHRAGM PUMP



# DP0110-Y1 (24 V DC)

### Airflow & Electric Current

### Specifications

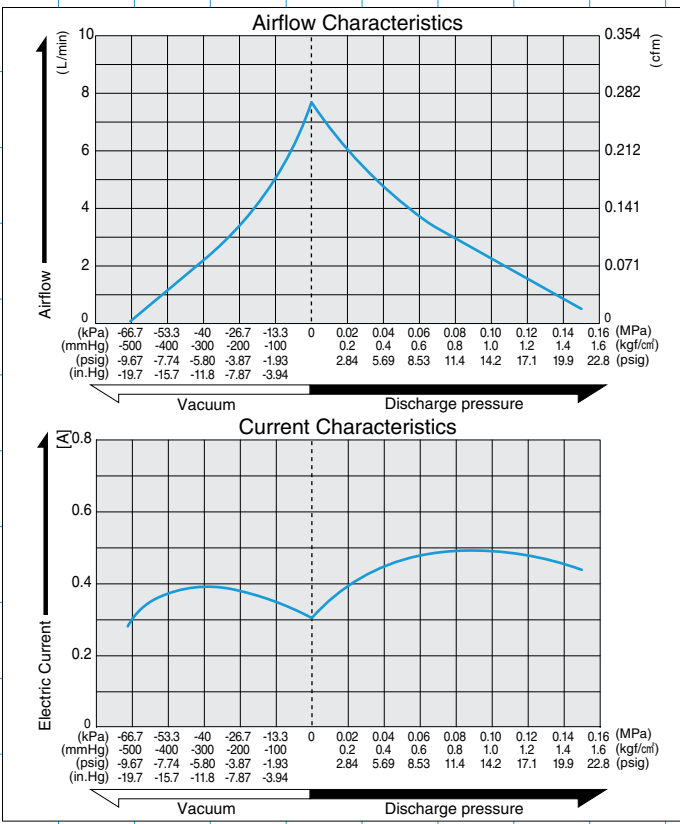

	(SI)	(EURO)	(U.S.A.)
Free Air Displacement	7.5 L/min		0.26 cfm
Rated Voltage	24 V DC		
Maximum Pressure	0.15 MPa {1.5 kgf/cm <sup>2</sup> }	1.5 bar	21.3 psig
Maximum Current	0.6 A or less		
Attainable Vacuum	-66.6kPa (-500mmHg)	-666 mbar	-19.7 in.Hg
Rated Operating Time	Continuous		
Life Expectancy	5,000 hours		
Inlet and Outlet	6 mm O.D. straight nipple		
Coil Insulation Class	A or its equivalent (JTEL)		
Mounting Dimensions	50 mm(L) x 30 mm(W)	1- <sup>31</sup> / <sub>32</sub> "(L) x 1- <sup>3</sup> / <sub>16</sub> "(W)	
Gross Weight	0.30 kg	0.66 Lbs.	
Leadwire Length	360 mm	14- <sup>3</sup> / <sub>16</sub> "	

Please read the page of "How to Use This Catalog" first for correct use of compressors and pumps.

### Application Examples

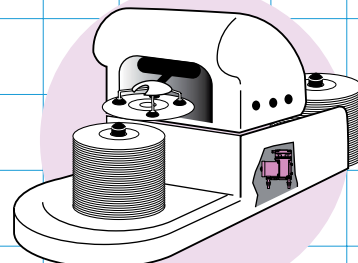

Vacuum pick up and place devices for CD & DVD

### Sketch Drawing and Mounting Dimensions Diagram (mm)

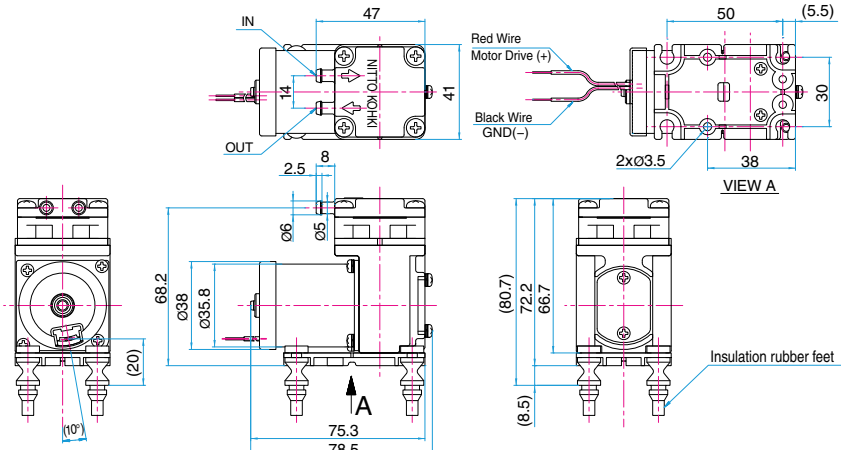

# DC AIR PUMP

## DIAPHRAGM PUMP



# DP0110 PWM

### Airflow & Electric Current

### Specifications

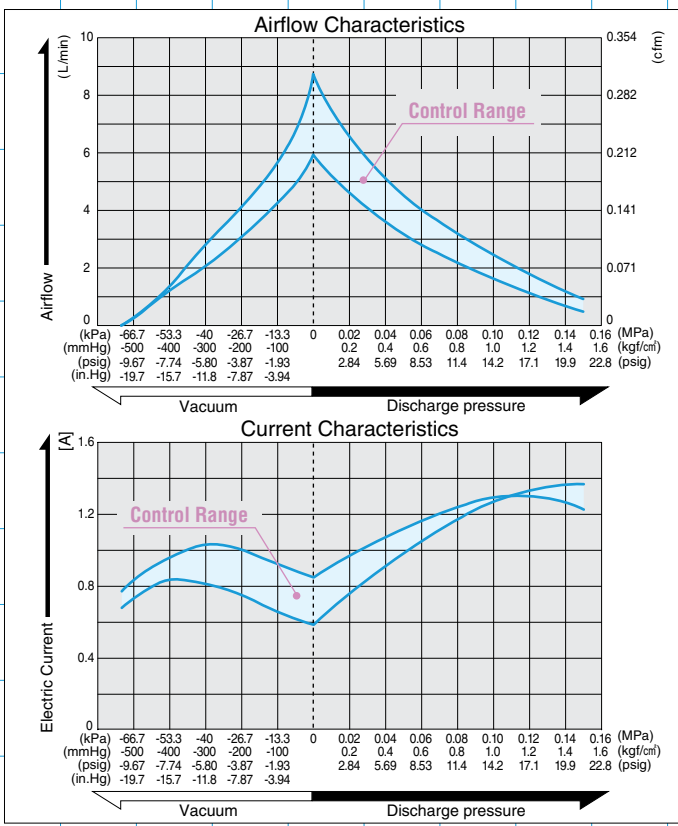

	(SI)	(EURO)	(U.S.A.)
Free Air Displacement	7.5 L/min		0.26 cfm
Rated Voltage	12 V DC		
Maximum Pressure	0.15 MPa {1.5 kgf/cm <sup>2</sup> }	1.5 bar	21.3 psig
Maximum Current	1.4 A or less		
Attainable Vacuum	-66.6kPa (-500mmHg)	-666 mbar	-19.7 in.Hg
Rated Operating Time	Continuous		
Life Expectancy	5,000 hours		
Control (PWM) <sup>※1</sup>	2.5-5 V, 15 - 25 kHz, Duty cycle 80 - 100%		
Inlet and Outlet	6 mm O.D. straight nipple		
Coil Insulation Class	A or its equivalent (JTEL)		
Mounting Dimensions	50 mm(L) x 30 mm(W)	1- <sup>31</sup> / <sub>32</sub> "(L) x 1- <sup>3</sup> / <sub>16</sub> "(W)	
Gross Weight	0.30 kg	0.66 Lbs.	
Leadwire Length	180 mm	7"	

※1: PWM= Pulse Width Modulation  
Please read the page of "How to Use This Catalog" first for correct use of compressors and pumps.

### Application Examples

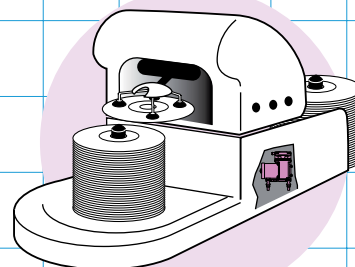

Vacuum pick up and place devices for CD & DVD

### Sketch Drawing and Mounting Dimensions Diagram (mm)

**Mounting Dimension of Rubber Foot:**  
 Plate thickness : t=2mm,  
 Hole diameter :  $\phi 6 \pm 0.1$ mm  
 (Rubber feet come with the product as accessories.)

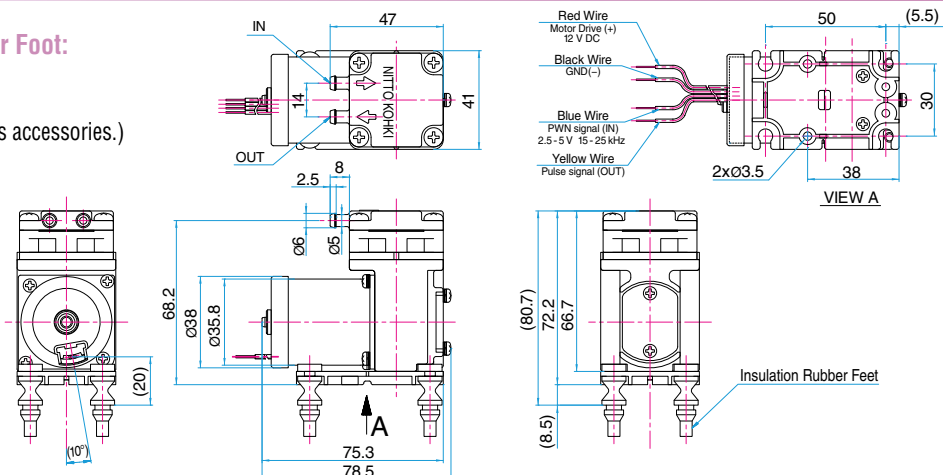

# LIQUID PIEZOELECTRIC PUMP

BPS type  
BPH type  
BPF type  
P83-86

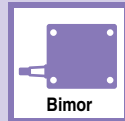

# LIQUID MINIATURE DIAPHRAGM PUMP

DPE-100  
P88

DPE-400  
P89

DPE-400BL  
P90

DPE-800  
P91



# BIMOR PUMP



## PIEZOELECTRIC PUMP





**Suitable for pumping both liquids and gases!**

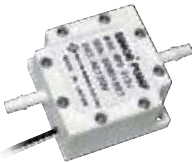
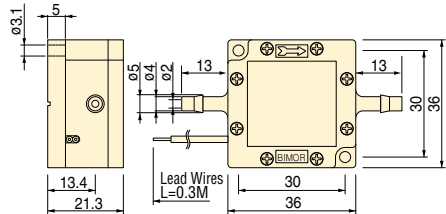

### Compact, lightweight, durable & quiet

As the Bimorph also acts as a diaphragm it has no motors or shafts or other troublesome mechanisms, and thus minimal vibrations and fewer breakdowns. The Bimor is lighter, quieter and more durable than traditional pumps.

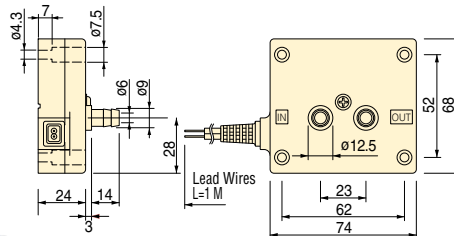
We have achieved maintenance free continuous operation for 60 months.

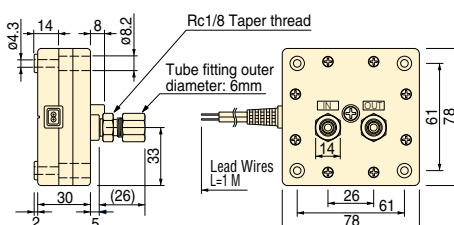
Specifications	Dimensions	Voltage(AC) — 120V 60Hz				
		Model	Current (mA)	Self-priming Pressure(kPa)	FlowRate (mL/min)	Discharge Pressure (kPa)
<b>BPS</b> type 		BPS-215i	3	3	30	15
		BPS-235G	3	1.5	30	15
<b>BPH</b> type 		BPH-214i	15	8	350	18
		BPH-214D				
		BPH-214E				
		BPH-214G	7	17		
		BPH-414i	30	12	500	35
		BPH-414D				
		BPH-414E				
		BPH-414G				
BPH-474G	10	400	35			
BPH-474P						
<b>BPF</b> type 		BPF-465P	30	10	400	35

**The performance data is measured at the rated conditions.**

- 1)The reference data is based on water at 25 degrees Celsius with unloaded condition.
- 2)The ambient operating temperature range is from 5 to 50 degrees Celsius, the ambient liquid temperature range is from 5 to 50 degrees Celsius (non-freezing), and the ambient operating humidity range is from 35 to 85% (non-condensing). When the liquid temperature is low, the valve will be hardened. As a result, the flow rate will be decreased. This could be applied for liquids with high viscosity. The materials that will be under influence of the applied liquids or gases are the housing, liquid contact sheets, valves, and O-rings. Please confirm the suitability under any

applied conditions. Any minute quantities of additives and composite materials found in certain liquids may influence the performance of the unit several months later.

- 3)You may use the product at low voltage, but it will result in lower outlet pressure.
- 4)Performance may be compromised by restrictive tubing/piping or mounting position of the pump in the application.
- 5)The above performance data is measured at the rated condition as we described.

Note: The Bimor does not fulfill explosion-proof construction in any applications. Please install isolating transformers or similar protective devices on the wiring for your safety.

## Low power consumption & electromagnetic noise

The Bimor is driven by low energy consuming piezoelectric elements. Consequently it costs very little to run and emits virtually no electromagnetic noise.

## Simple flow rate adjustment

As the flow rate of the Bimor is proportional to the voltage and frequency, adjusting the flow rate is as simple as adjusting either one. You may use the product at the rated voltage or lower.

## Application versatility

The parts can be made of several different materials, so you can select the material appropriate to your needs, be it a liquid or gas application. The Bimor is currently employed in a variety of different fields including medicine, scientific research, and the PC and chemical industries.

The following "Examples of suitable chemical liquids and gases" should be used for reference only. Please confirm the suitability under any applied conditions by yourself.

## Applications



- For supply and drainage
- For cooling circulation
- For medical injection
- For sampling



- For pressure expansion
- For sampling (inhale)

Model	Voltage(AC) — 230V 50Hz				Liquid Surface Materials			Mass (g)	Examples of suitable chemical liquids and gases	Examples of unsuitable chemical liquids and gases
	Current (mA)	Self-priming Pressure(kPa)	FlowRate (mL/min)	Discharge Pressure (kPa)	Housing	Liquid Contact Sheet	Valve/O-ring			
BPS-215i	4	0.4	10	10	PP	PP	IIR	40	Ethanol, Dilute hydrochloric acid, Sodium carbonate, Benzaldehyde, Formalin	Xylene, Mineral oil, Carbon tetrachloride, Trichloroethylene, Toluene, Benzene
BPS-235G					POM	PTFE	FKM			
BPH-214i	15	7	220	18	PP	PP	IIR	140	Ethanol, Dilute hydrochloric acid, Sodium carbonate, Benzaldehyde, Formalin	Xylene, Mineral oil, Carbon tetrachloride, Trichloroethylene, Toluene, Benzene
BPH-214D							VMQ			
BPH-214E							EPDM			
BPH-214G							FKM			
							IIR	140	Ethanol, Dilute hydrochloric acid, Sodium carbonate, Benzaldehyde, Formalin	Xylene, Mineral oil, Carbon tetrachloride, Trichloroethylene, Toluene, Benzene
						PP	VMQ			
							EPDM			
							FKM			
BPH-274G	15	7	250	35	PPS	PTFE	FKM	170	Ethanol, Xylene, Carbon tetrachloride, Silicone oil, Trichloroethylene	Acetone, Ammonia water, Chlorosulfonic acid, Glacial acetic acid, Hydrofluoric acid, Formalin
BPH-274P							FFKM FEP			
							FFKM FEP	350	Ethanol, Aqua regia, Ozone, Carbon tetrachloride, Concentrated nitric acid, Concentrated sulfuric acid, Fuming sulfuric acid	Fluorine oil, CFC 112, CFC 113
BPF-265P	15	7	250	35	PFA	PTFE				

BPS type

BPH type

BPF type

### Material Description

- EPDM --- Ethylene Propylene Rubber
- FEP --- Fluoroethylene Propylene
- FFKM --- Fluorine Rubber (Perfluoro)
- FKM --- Fluorine Rubber
- IIR --- Butyl Rubber
- POM --- Polyacetal
- PFA --- Fluororesin (Perfluoroalkoxy)
- PP --- Polypropylene
- PPS --- Polyphenylene Sulphide
- PTFE --- Tetrafluoro-resin (Polytetrafluoroethylene)
- VMQ --- Dimethyl Silicon Rubber

## Durability

Longevity test : ● Sample A ● Sample B ● Sample C ● Sample D

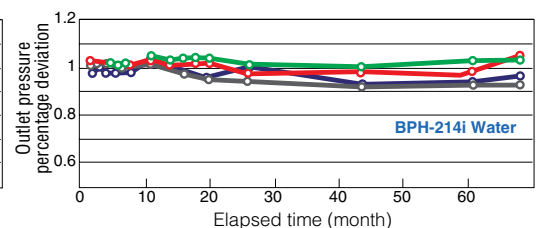
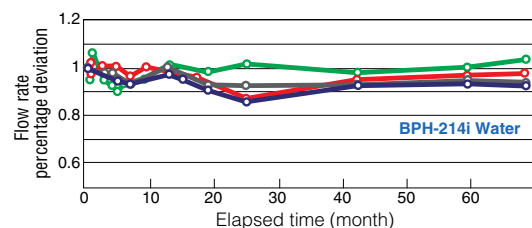

# BIMOR PUMP



## PIEZOELECTRIC PUMP

### Flow Rate Characteristic

#### BPS series

120V 60Hz type      230V 50Hz type

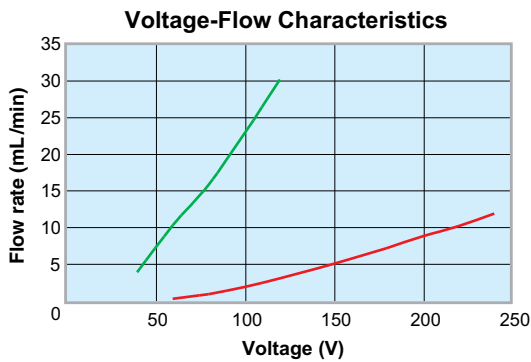
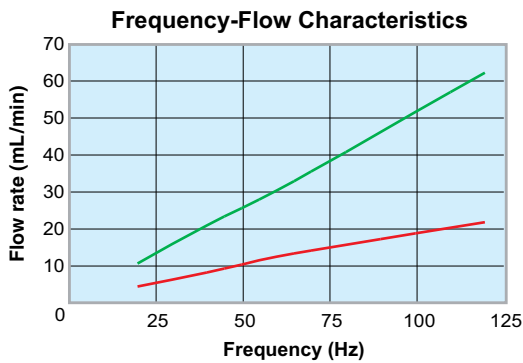
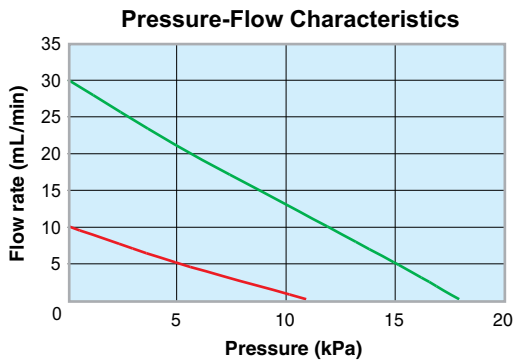

#### BPH series

(BPH-414i)      (BPH-214i)      (BPH-214i)  
 120V 60Hz type    120V 60Hz type    230V 50Hz type

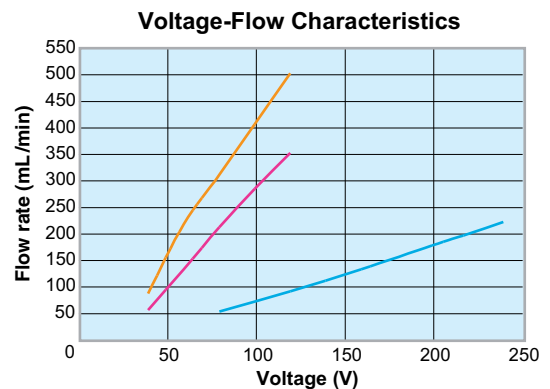
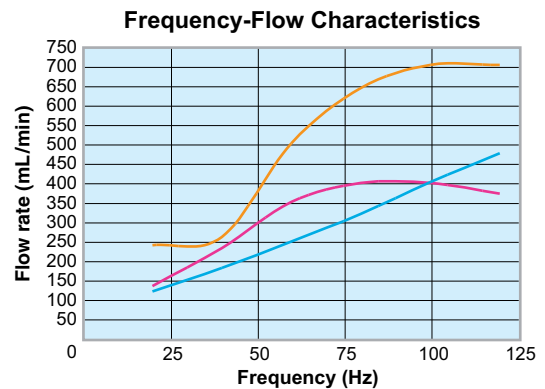
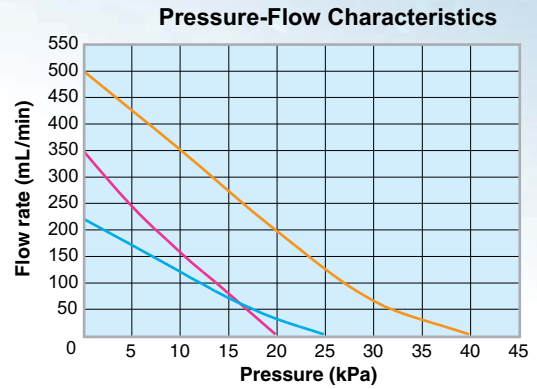

## PIEZOELECTRIC PUMP

# The Next Step in Pump Miniaturization

## <Revolutionary piezoelectric bimorph technology>

The Bimor's driving force, the bimorph, comprises two parallel piezoelectric wafers. Their nature is to expand or contract depending on the direction of the voltage. Therefore when an alternating current is applied, one wafer expands then contracts while the other contracts then expands, causing the bimorph to bend. Repeating the cycle creates the pumping action.

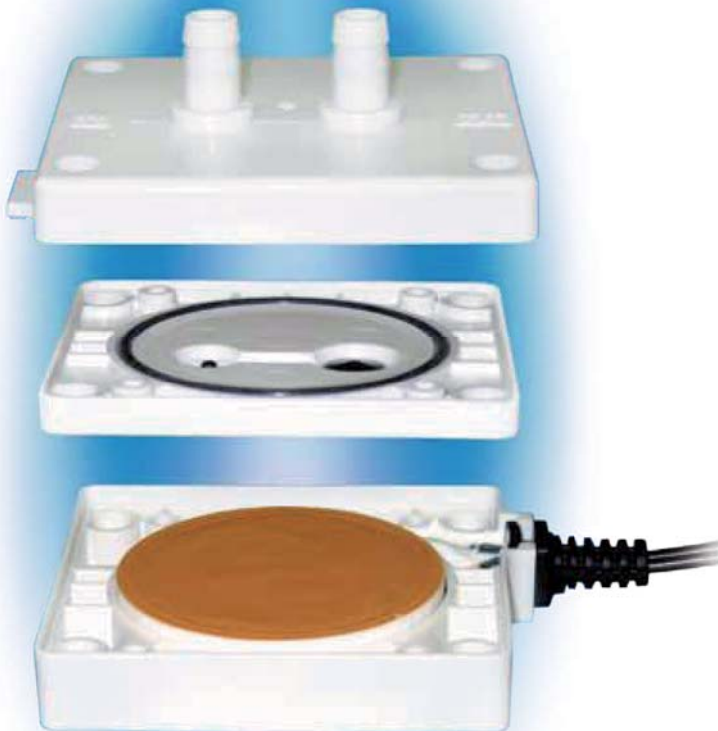

## Cross section

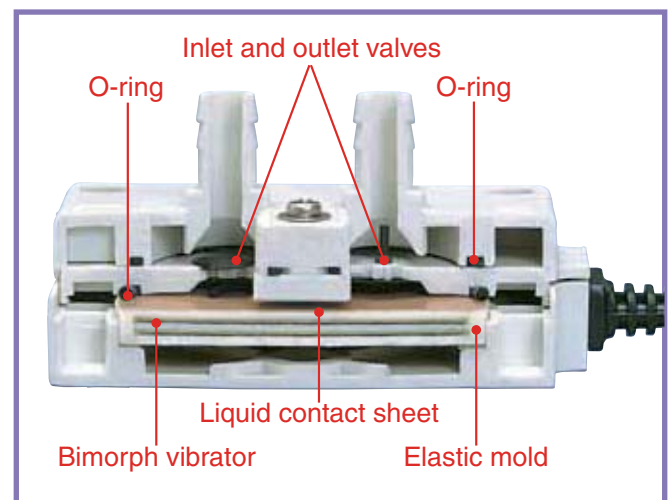

## Principle / Structure

"The Bimor pump" uses the displacement operation of the piezoelectric bimorph vibrator as the direct source of the pumping action.

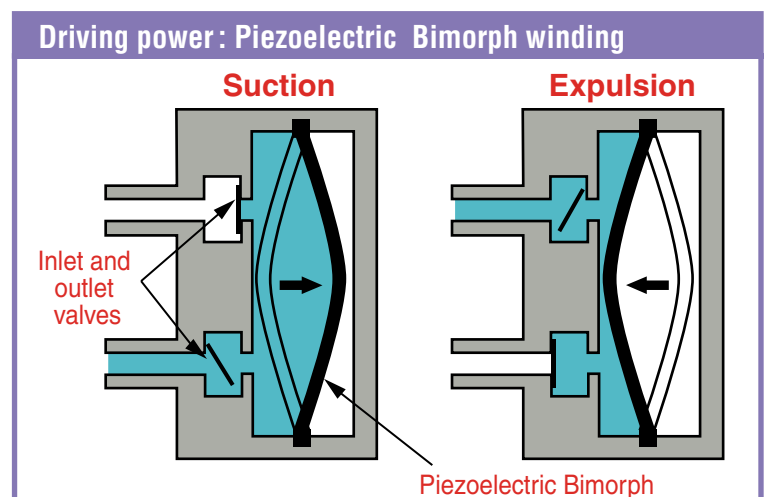

# DC LIQUID PUMP



## DIAPHRAGM PUMP

- **Built-in Pulse Absorption Chamber**
- **Many build material options for different liquids**
- **Self-priming type with air suction acceptable**

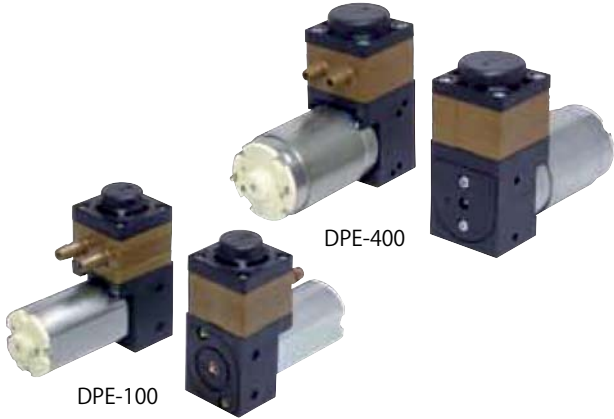

### Typical Conventional Pump without Pulse Absorption

As liquid is transported through the suction and discharge passages of the pump and liquid circuit, high pulsations can be created which can cause cavitation, vibration in tubing, fittings, peak pulsing noises, and added stress and wear to pump mechanisms. These negative results are often increased through the use of small pumps having relatively high rotational speeds.

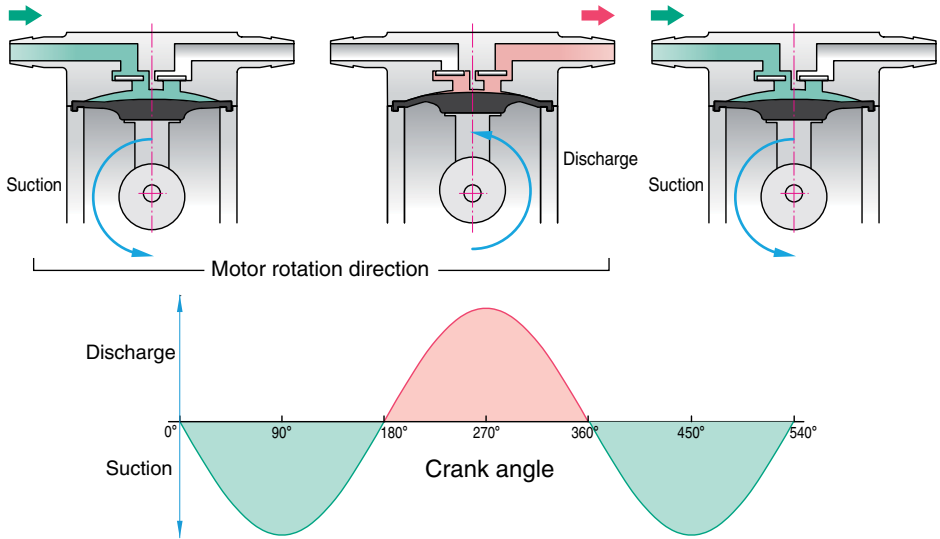

### Advanced design DPE Pump with Pulse Absorption

Provides pulse attenuation which helps to create steady state flow, reduced noise and vibration throughout the fluid circuit, and enhances life of the pump and other circuit components. It's designed in... No need for additional installation cost or space with pulsation dampers.

- ① Suction
- ② Discharge. Partial fluid delivery to pulse absorption chamber, not directly forced to outlet port.
- ③ Cyclical suction drawn into pump is synchronized with the discharge.

Pulses are attenuated through the process of ② and ③.

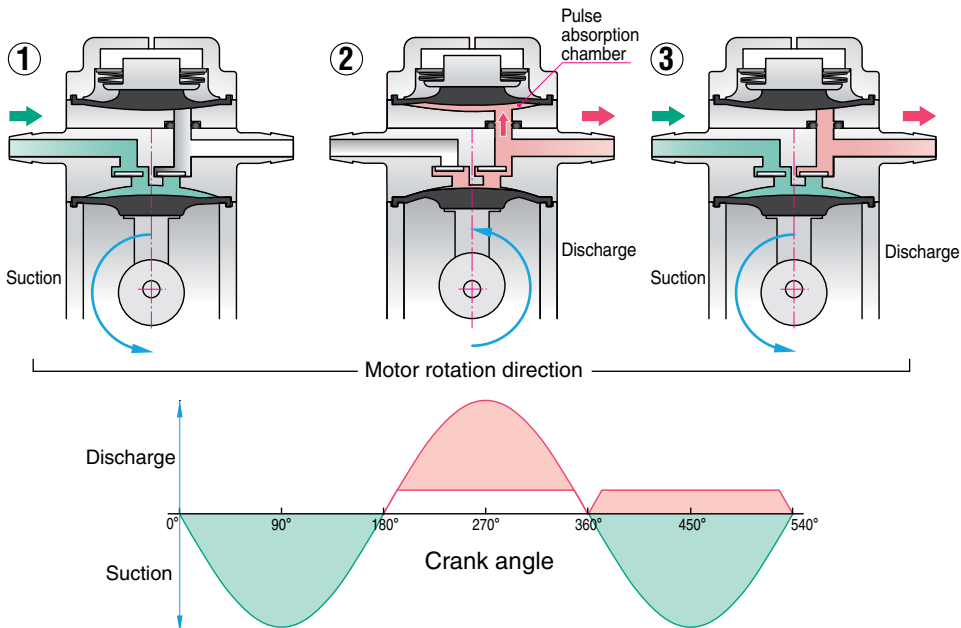



# DC LIQUID PUMP

## DPE-100

### DIAPHRAGM PUMP



#### Flow & Electric Current

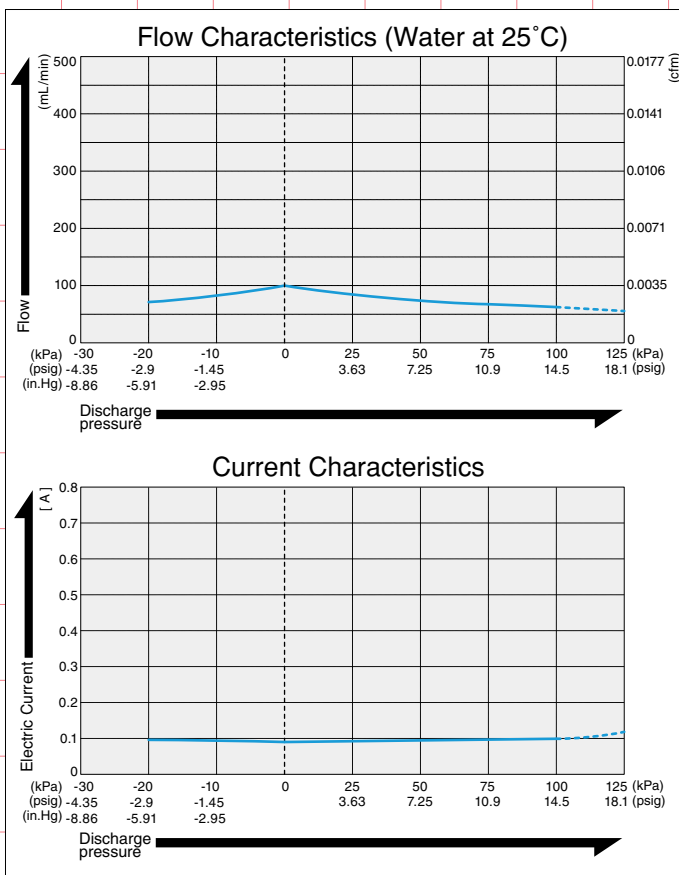

#### Specifications

	(SI)	(EURO)	(U.S.A.)
Rated Voltage	24 V DC		
Flow Rate ※1	100 mL/min		
Working Pressure Range	0~100 kPa	0~1 bar	0~14.5 psig
Maximum Pressure ※2	300 kPa	3 bar	43.5 psig
Maximum Current	100 mA		
Rated Operating Time	Continuous		
Life Expectancy (MTTF)	500 hours		
Self-priming Pressure ※1	20 kPa		
Inlet & Outlet	4.7 mm O.D. straight nipple		
Insulation Classification	E class equivalent		
Mounting Dimensions	9.5 mm(L) x 17 mm(W)	3/8" (L) x 43/64" (W)	
Gross Weight	67 g		0.148 Lbs.
Motor	DC Brush Motor		

※1: When the check valve is hardened due to low liquid temperature, self-priming performance and flow rate will go down.  
 ※2: Restarting pumps with flow passage closed is impossible.  
 Please read the page of "How to Use This Catalog" first for correct use of compressors and pumps.

#### Build materials and applicable fluids

Model	Cylinder Head	Head Cover	Diaphragm	Valve	O-ring	Applicable fluids
DPE-100-2E	PA Polyamide(Nylon)	PTFE Polytetrafluoroethylene	PTFE Polytetrafluoroethylene	EPDM Ethylene-propylene rubber	FKM Fuluro rubber	Sodium hydroxide, Citric acid Ammonia water, Caustic potash
DPE-100-2G						Ethanol, Ethylene glycol Sodium carbonate, mineral oil
DPE-100-7G	PPS Polyphenylene sulfide	PTFE Polytetrafluoroethylene	PTFE Polytetrafluoroethylene	FKM Fuluro rubber	FFKM Perfluoroelastomer	Xylene, Carbon tetrachloride Trichloroethylene, Silicon oils
DPE-100-7P						Chloroform, Benzene Glacial acetic acid, Methyl ethyl ketone

#### Applications

- Liquid analytical instruments e.g. medical, food, water treatment & environmental.
- Liquid transport within filtration, sampling, sterilizers and washers.
- Ink transport within industrial ink-jet printers.

#### Sketch Drawing and Mounting Dimensions Diagram (mm)

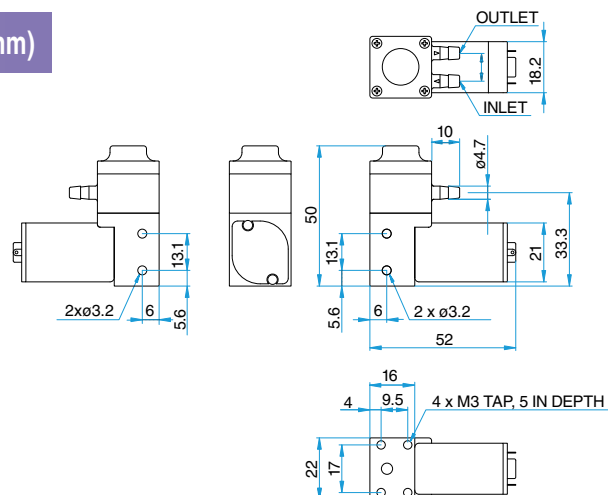

# DC LIQUID PUMP

## DIAPHRAGM PUMP



# DPE-400

### Flow & Electric Current

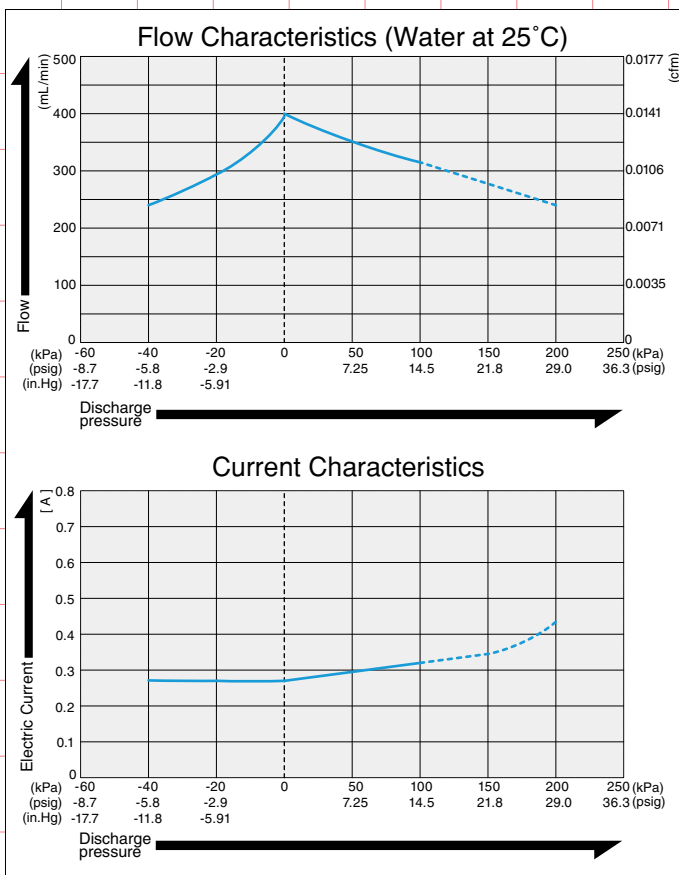

### Specifications

	(SI)	(EURO)	(U.S.A.)
Rated Voltage	24 V DC		
Flow Rate ※1	400 mL/min		
Working Pressure Range	0~100 kPa	0~1 bar	0~14.5 psig
Maximum Pressure ※2	300 kPa	3 bar	43.5 psig
Maximum Current	345 mA		
Rated Operating Time	Continuous		
Life Expectancy (MTTF)	500 hours		
Self-priming Pressure ※1	40 kPa		
Inlet & Outlet	5.4 mm O.D. straight nipple		
Insulation Classification	F class equivalent		
Mounting Dimensions	19 mm(L) x 26 mm(W)		3/4"(L) x 1-1/32"(W)
Gross Weight	187 g		0.412 Lbs.
Motor	DC Brush Motor		

※1: When the check valve is hardened due to low liquid temperature, self-priming performance and flow rate will go down.  
 ※2: Restarting pumps with flow passage closed is impossible.  
 Please read the page of "How to Use This Catalog" first for correct use of compressors and pumps.

### Build materials and applicable fluids

Model	Cylinder Head	Head Cover	Diaphragm	Valve	O-ring	Applicable fluids
DPE-400-2E	PA Polyamide(Nylon)	PTFE Polytetrafluoroethylene	PTFE Polytetrafluoroethylene	EPDM Ethylene-propylene rubber	FKM Fuluro rubber	Sodium hydroxide, Citric acid Ammonia water, Caustic potash
DPE-400-2G						Ethanol, Ethylene glycol Sodium carbonate, mineral oil
DPE-400-7G	PPS Polyphenylene sulfide	PTFE Polytetrafluoroethylene	PTFE Polytetrafluoroethylene	FKM Fuluro rubber	FFKM Perfluoroelastomer	Xylene, Carbon tetrachloride Trichloroethylene, Silicon oils
DPE-400-7P						Chloroform, Benzene Glacial acetic acid, Methyl ethyl ketone

### Applications

- Liquid analytical instruments e.g. medical, food, water treatment & environmental.
- Liquid transport within filtration, sampling, sterilizers and washers.
- Ink transport within industrial ink-jet printers.

### Sketch Drawing and Mounting Dimensions Diagram (mm)

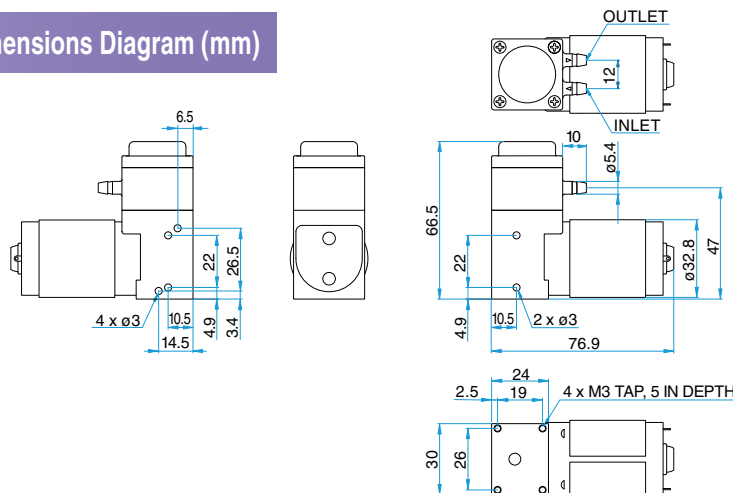

# DC LIQUID PUMP

## DIAPHRAGM PUMP

# DPE-400BL



### Flow & Electric Current

### Specifications

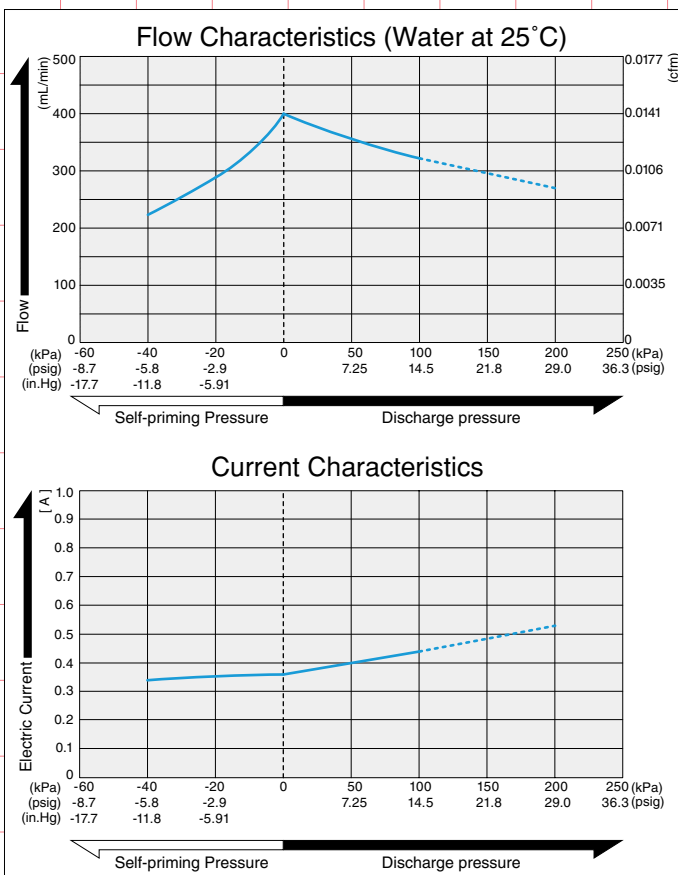

	(SI)	(EURO)	(U.S.A.)
Rated Voltage	24 V DC		
Flow Rate <sup>※1</sup>	400 mL/min		0.0141 cfm
Working Pressure Range	0~100 kPa	0~1 bar	0~14.5 psig
Maximum Pressure <sup>※2</sup>	300 kPa	3 bar	43.5 psig
Maximum Current (Reference)	450 mA		
Rated Operating Time	Continuous		
Life Expectancy (MTTF) <sup>※3</sup>	5,000 hours		
Self-priming Pressure <sup>※1</sup>	40 kPa		
Inlet & Outlet	5.4 mm O.D. straight nipple		
Insulation Classification	A class equivalent		
Mounting Dimensions	41 mm(W)	1-19/32"(W)	
Gross Weight	230 g		0.507 Lbs.
Motor	DC Brushless Motor		

<sup>※1</sup>: At low temperature, the performance may reduce.  
<sup>※2</sup>: Pumps may not re-start against high backpressure.  
<sup>※3</sup>: Life expectancy is based on the following conditions:  
 Rated voltage: 24 V DC  
 Atmospheric pressure: 0 kPa  
 Fluid: water at 25°C  
 Please read the page of "How to Use This Catalog" first for correct use of compressors and pumps.

### Build materials and applicable fluids

Model	Cylinder Head	Head Cover	Diaphragm	Valve	O-ring	Applicable fluids
DPE-400BL-2E	PA Polyamide(Nylon)	PTFE	Polytetrafluoroethylene	EPDM	EPDM	Sodium hydroxide, Citric acid Ammonia water, Caustic potash
DPE-400BL-2G				Ethylene-propylene rubber	Ethylene-propylene rubber	Ethanol, Ethylene glycol Sodium carbonate, mineral oil
DPE-400BL-7G	PPS Polyphenylene sulfide	PTFE	Polytetrafluoroethylene	FKM	FKM	Ethanol, Carbon tetrachloride Trichloroethylene, Silicon oils
DPE-400BL-7P				FFKM	Perfluoroelastomer	Chloroform, Benzene Glacial acetic acid, Methyl ethyl ketone

The chemicals shown are for reference only. Please confirm suitability of materials in each application.

### Applications

- Liquid analytical instruments e.g. medical, food, water treatment & environmental.
- Liquid transport within filtration, sampling, sterilizers and washers.
- Ink transport within industrial ink-jet printers.

### Sketch Drawing and Mounting Dimensions Diagram (mm)

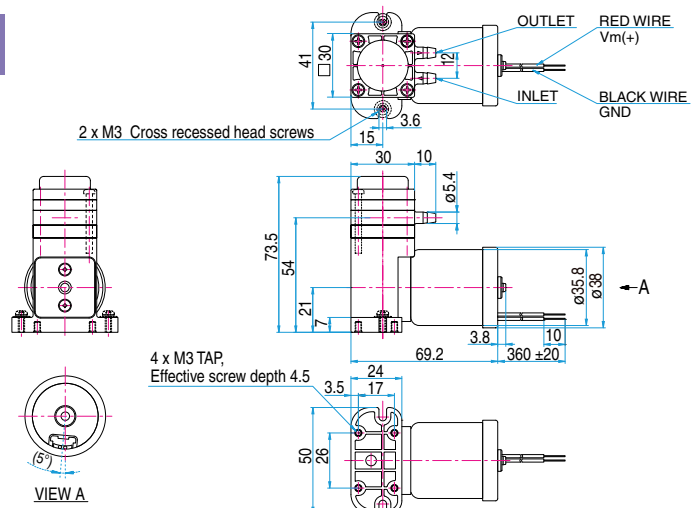

# DC LIQUID PUMP

# DPE-800

## DIAPHRAGM PUMP



### Flow & Electric Current

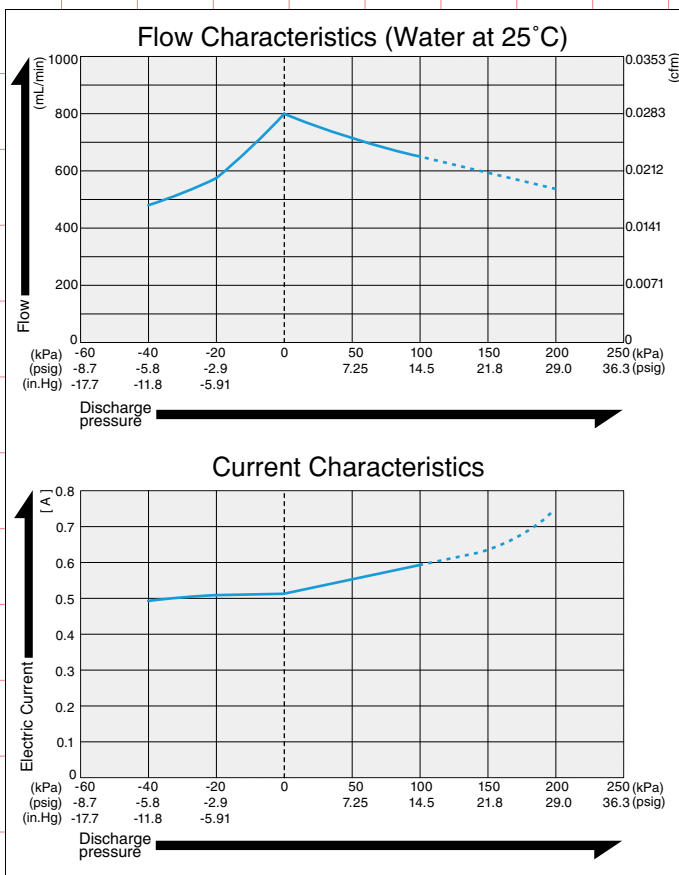

### Specifications

	(SI)	(EURO)	(U.S.A.)
Rated Voltage	24 V DC		
Flow Rate ※1, ※3	800 mL/min		0.0282 cfm
Working Pressure Range	0~100 kPa	0~1 bar	0~14.5 psig
Maximum Pressure ※2	300 kPa	3 bar	43.5 psig
Maximum Current	600 mA		
Rated Operating Time	Continuous		
Life Expectancy (MTTF)	600 hours		
Self-priming Pressure ※1	40 kPa		
Inlet & Outlet	5.4 mm O.D. straight nipple		
Insulation Classification	E class equivalent		
Mounting Dimensions	74.5 mm(L) x 41 mm(W)	2-15/16" (L) x 1-19/32" (W)	
Gross Weight	350 g		0.771 Lbs.
Motor	DC Brush Motor		

※1: When the check valve is hardened due to low liquid temperature, self-priming performance and flow rate will go down.  
 ※2: Restarting pumps with flow passage closed is impossible.  
 ※3: Tubing in series between the two pumping heads should not be made. This may cause extreme pressure hike that will result in broken parts, liquid splash out or possible ignition.  
 Please read the page of "How to Use This Catalog" first for correct use of compressors and pumps.

### Build materials and applicable fluids

Model	Cylinder Head	Head Cover	Diaphragm	Valve	O-ring	Applicable fluids
DPE-800-2E	PA Polyamide(Nylon)	PTFE Polytetrafluoroethylene	PTFE Polytetrafluoroethylene	EPDM Ethylene-propylene rubber	FKM Fuluro rubber	Sodium hydroxide, Citric acid Ammonia water, Caustic potash
DPE-800-2G						Ethanol, Ethylene glycol Sodium carbonate, mineral oil
DPE-800-7G	PPS Polyphenylene sulfide	PTFE Polytetrafluoroethylene	PTFE Polytetrafluoroethylene	FKM Fuluro rubber	FFKM Perfluoroelastomer	Xylene, Carbon tetrachloride Trichloroethylene, Silicon oils
DPE-800-7P						Chloroform, Benzene Glacial acetic acid, Methyl ethyl ketone

### Applications

- Liquid analytical instruments e.g. medical, food, water treatment & environmental.
- Liquid transport within filtration, sampling, sterilizers and washers.
- Ink transport within industrial ink-jet printers.

### Sketch Drawing and Mounting Dimensions Diagram (mm)

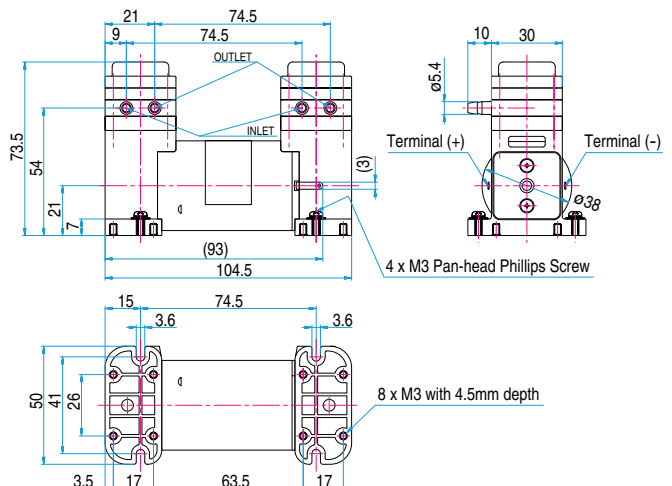



## OTHER PRODUCTS

**VACUUM TWEEZERS**

# MEDO HAND

**MH-100A**

**Easy transfer of miniature components!**

MH-100A  
P93

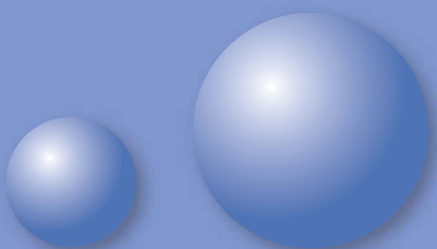

# MEDO HAND

## Model **MH-100A**

*One touch pick and place action for easy transfer of miniature components!*

**NEW**

Duster function is also available

Easy to handle pen type tweezers

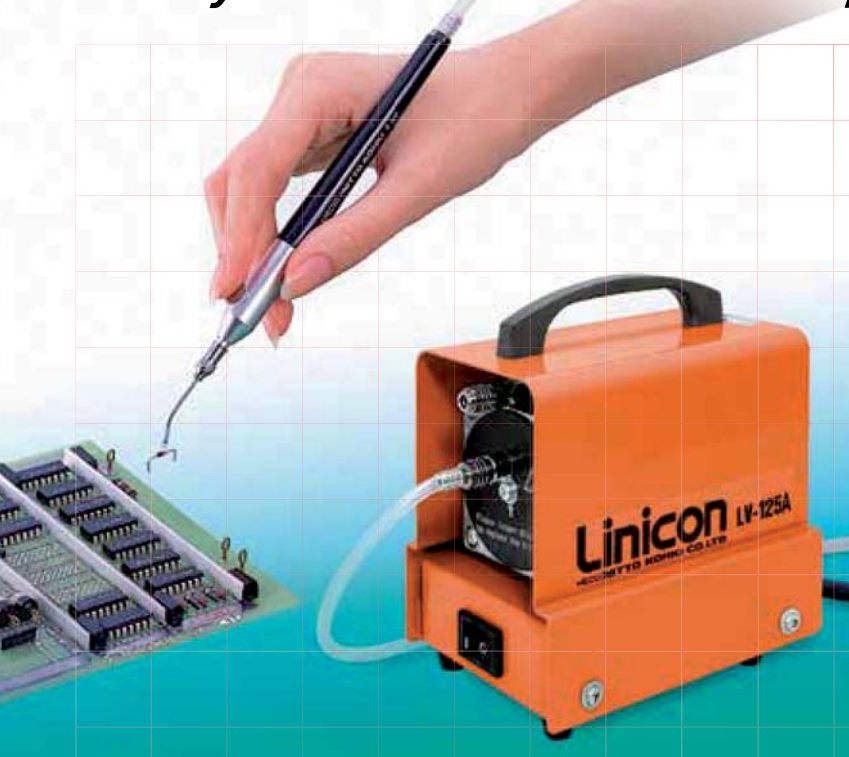

### Specifications



#### MH-100A is composed of:

- Vacuum Pump Unit Linicin Model LV-125A including 1 pc. of Micro Cupla MC04PH
- Tube 3 x 5 x 2000mm : 1 pc.
- Tweezer (P-100): 1 set
- Stand : 1 pc.
- Needle 1 x 1.5 x 40 : 1 pc.
- Pad 6 mm dia. : 1 pc.
- Pad 4 mm dia. : 1 pc.

The needle can be bent in accordance with applications. Please read the instruction booklet on how to bend the needle.

### Applications



Transferring sphere objects such as balls

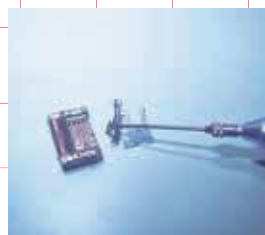

Assembling precision parts



Moving tiny parts



Transferring uneven parts

Most suitable for handling electronic parts such as ICs and LSIs. Also precise micro parts such as watches, chemicals and other small parts.

#### Specifications of Vacuum Pump Unit Linicon Model LV-125A

Rated Voltage	115 V AC	230 V AC
Power Consumption	15/14 W	15/14 W
Rated Frequency	50/60 Hz	50/60 Hz
Maximum Vacuum	-33.3 kPa { -250 mmHg }, -333 mbar, -9.84 in.Hg }	
Dimensions	135 mm(L) x 84 mm(W) x 146 mm (H) (5-5/16" x 3-11/32" x 5-3/4")	
Duty Cycle	Continuous	
Coil Insulation Class	B or its equivalent	E or its equivalent
Weight	1.5 kg (3.3 lbs.)	

Made-to-order Item

# AG LINEAR

**Air Compressor**

**Vacuum Pump**

**Diaphragm Pump**

AC0501  
P95

VP0645  
P96

VP0945  
P97

VP0660x2  
P98

VC0101S  
Dual Type  
P99

VC0101S  
Blower Type  
P100



# LINEAR

# Ac0501

Made-to-order COMPRESSOR



MOTOR FREE  
PISTON SYSTEM



## Airflow & Power Consumption

## Specifications

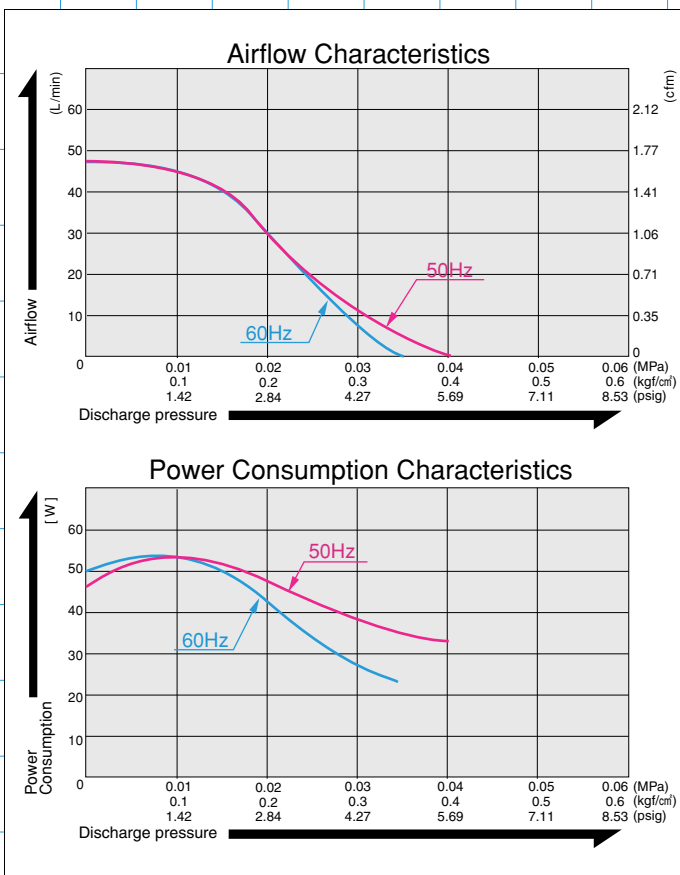

	(SI)	(EURO)	(U.S.A.)
Rated Pressure	0.01 MPa (0.1 kgf/cm <sup>2</sup> )	0.1 bar	1.42 psig
Rated Airflow	45 L/min		1.59 cfm
Rated Voltage	115 V AC or 230 V AC		
Maximum Pressure	0.035 MPa (0.35 kgf/cm <sup>2</sup> )	0.35 bar	4.98 psig
Power Consumption	53 W		
Rated Frequency	60 Hz & 50 Hz		
Life Expectancy	10,000 hours		
Outlet	ISO Rc 1/4 (female threaded)		
Duty Cycle	Continuous		
Coil Insulation Class	E or its equivalent (JETL)		
Mounting Dimensions	68 (L) x 84 (W) mm	2-11/16" (L) x 3-5/16" (W)	
Gross Weight	3 kg		6.6 Lbs.
Leadwire Length	200 mm		7-7/8"

Please read the page of "How to Use This Catalog" first for correct use of compressors and pumps.

## Application Examples

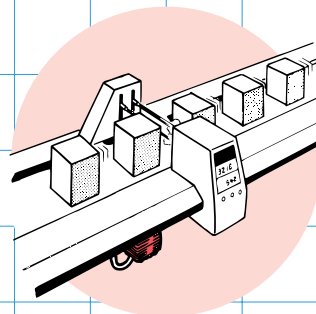

Pneumatic Sensor

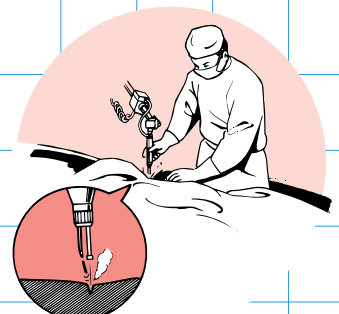

Laser Air Ventilation

## Sketch Drawing and Mounting Dimensions Diagram (mm)

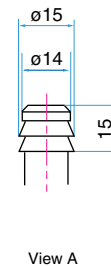
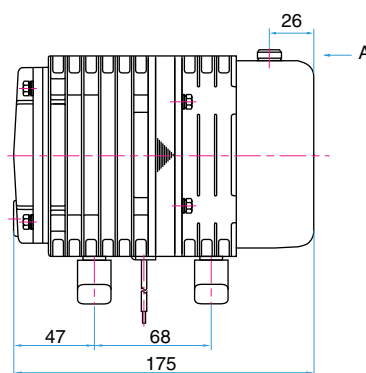
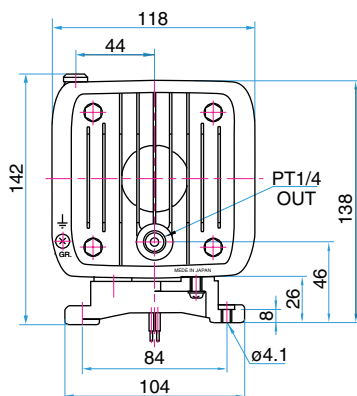



# LINEAR

# VP0645



MOTOR FREE  
PISTON SYSTEM



### Airflow & Power Consumption

### Specifications

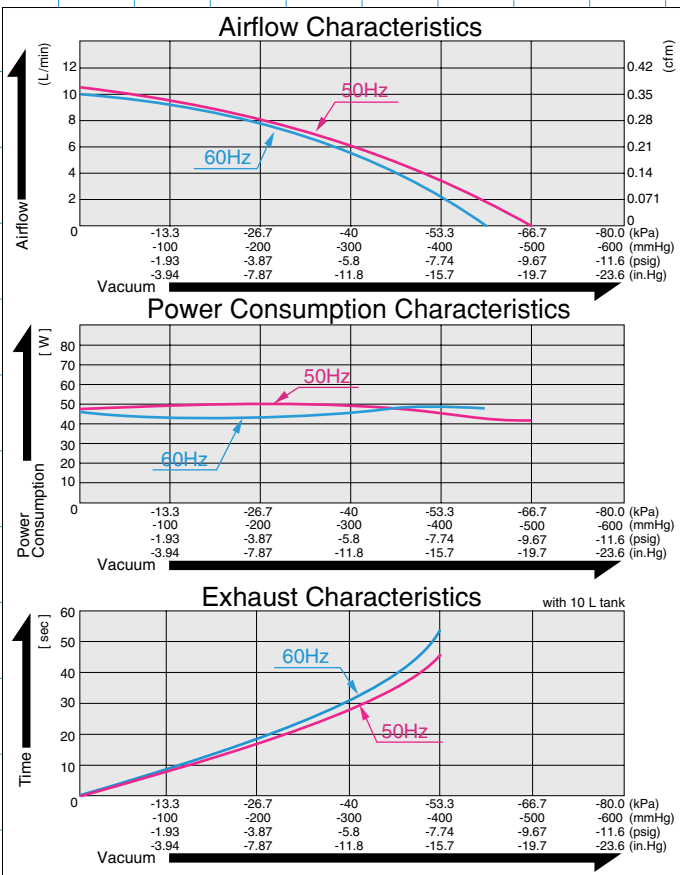

	(SI)	(EURO)	(U.S.A.)
Attainable Vacuum <sup>※1</sup>	-60 kPa (-450 mmHg)	-600 mbar	-17.7 in.Hg
Free Air Displacement	10 L/min		0.35 cfm
Rated Voltage	115 V AC or 230 V AC		
Power Consumption	48 W or 50 W		
Rated Frequency	60 Hz or 50 Hz		
Life Expectancy	3,000 hours		
Inlet	15 mm O.D. hose nipple		
Outlet	ISO Rc 1/4 (female threaded)		
Duty Cycle	Continuous		
Coil Insulation Class	E or its equivalent (JETL)		
Mounting Dimensions	68 (L) x 84 (W) mm	2-11/16" (L) x 3-5/16" (W)	
Gross Weight	3.2 kg	7.1 Lbs.	
Leadwire Length	200 mm	7-7/8"	

※1: Operations at higher than -60kPa need an additional leak valve or relief valve on the inlet piping. Please read the page of "How to Use This Catalog" first for correct use of compressors and pumps.

### Application Examples

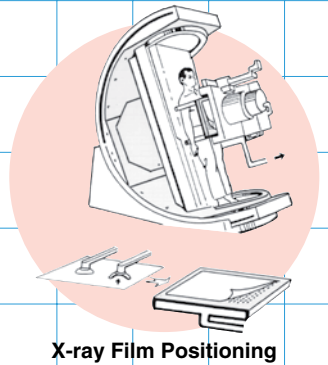
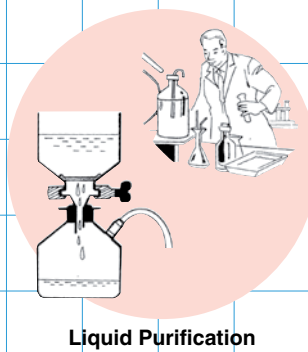

### Sketch Drawing and Mounting Dimensions Diagram (mm)

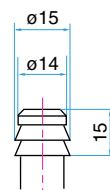
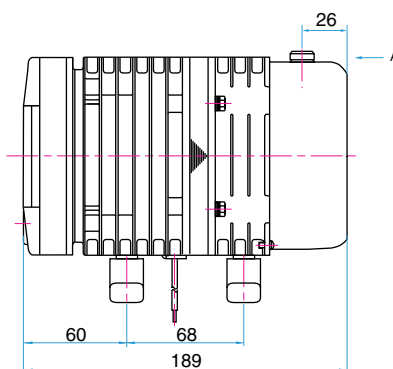
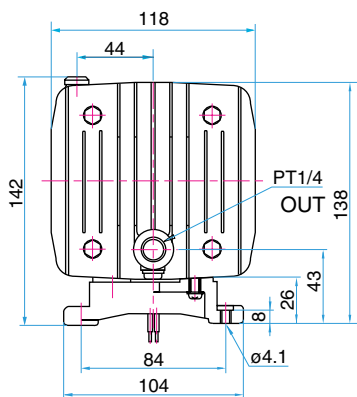

View A  
Inlet details

# LINEAR

# VP0945



MOTOR FREE  
PISTON SYSTEM



### Airflow & Power Consumption

### Specifications

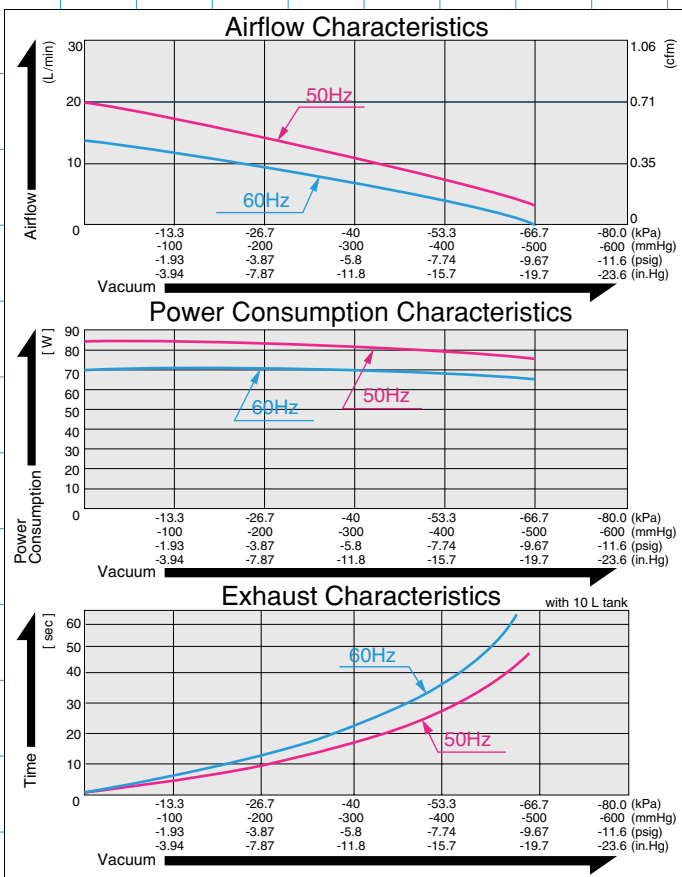

	(SI)	(EURO)	(U.S.A.)
Attainable Vacuum <sup>※1</sup>	-60 kPa (-450 mmHg)	-600 mbar	-17.7 in.Hg
Free Air Displacement	12 L/min		0.424 cfm
Rated Voltage	115 V AC or 230 V AC		
Power Consumption	70 W or 85 W		
Rated Frequency	60 Hz or 50 Hz		
Life Expectancy	3,000 hours		
Inlet	15 mm O.D. hose nipple		
Outlet	ISO Rc 1/4 (female threaded)		
Duty Cycle	Continuous		
Coil Insulation Class	E or its equivalent (JETL)		
Mounting Dimensions	102 (L) x 130 (W) mm	4" (L) x 5-1/8" (W)	
Gross Weight	4.9 kg		10.8 Lbs.
Leadwire Length	150 mm or 300 mm		5-7/8"

※1: Operations at higher than -60kPa need an additional leak valve or relief valve on the inlet piping. Please read the page of "How to Use This Catalog" first for correct use of compressors and pumps.

### Application Examples

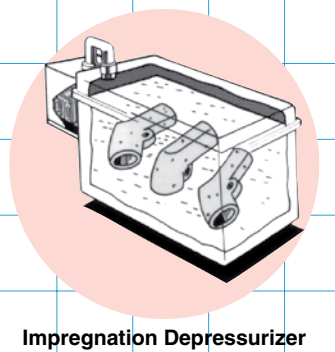
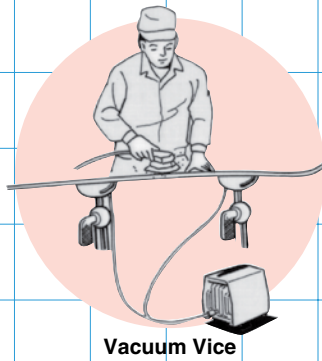

### Sketch Drawing and Mounting Dimensions Diagram (mm)

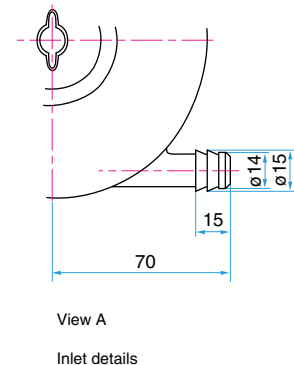
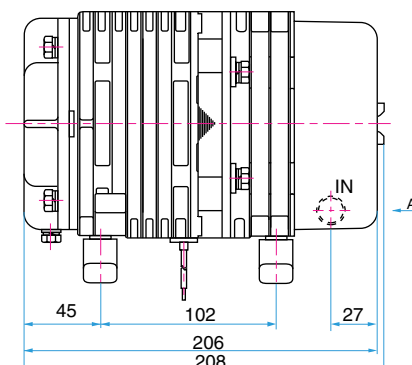
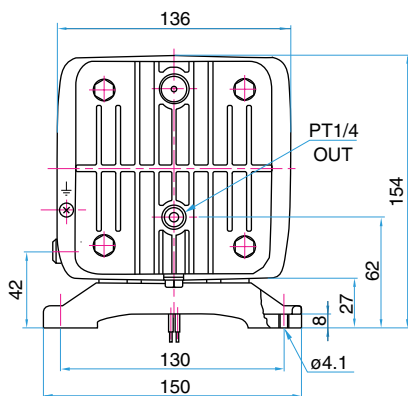

# LINEAR



MOTOR FREE  
PISTON SYSTEM



# VP0660x2

## Airflow & Power Consumption

## Specifications

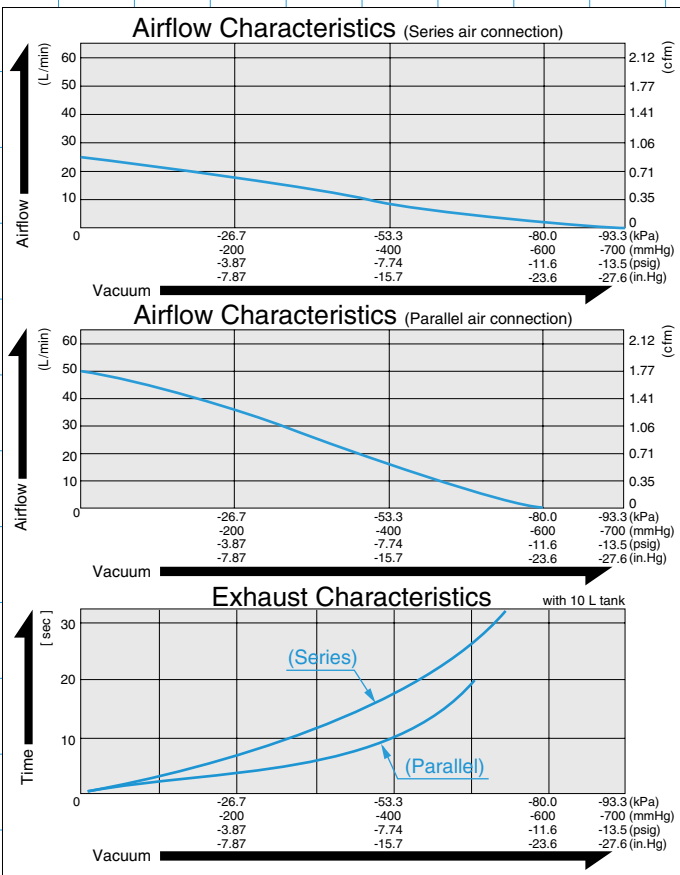

	Series Connection	Parallel Connection
Attainable Vacuum <sup>※1</sup>	-93.3 kPa (-700 mmHg) -933 mbar or -27.5 inHg	-80 kPa (-600 mmHg) -800 mbar or -23.6 inHg
Free Air Displacement	25 L/min or 0.88 cfm	50 L/min or 1.77 cfm
Rated Voltage	115 V AC or 230 V AC	
Power Consumption	125 W or 100 W	
Rated Frequency	60 Hz or 50 Hz	
Life Expectancy	6,000 hours	
Inlet	ISO Rc 1/4 (female threaded); 2 ports	
Outlet	ISO Rc 1/4 (female threaded); 2 ports	
Duty Cycle	Continuous	
Coil Insulation Class	B or its equivalent (JETL)	
Mounting Dimensions	280 (L) x 130 (W) mm { 11"(L) x 5-1/8"(W) }	
Gross Weight	10 kg (22 Lbs.)	
Leadwire Length	150 mm (5-7/8")	

※1: Operations at higher than -93.3kPa in series or -80kPa in parallel need an additional leak valve or relief valve on the inlet piping.  
Please read the page of "How to Use This Catalog" first for correct use of compressors and pumps.

## Application Examples

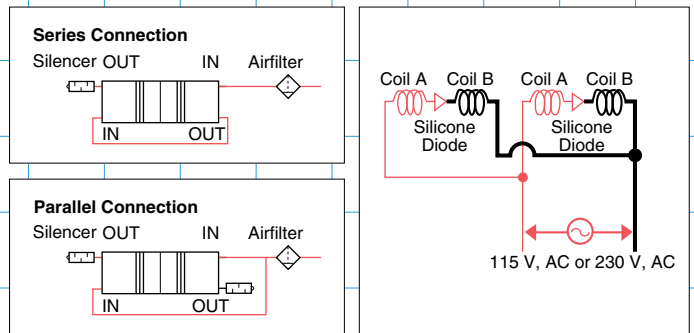

\* Air line connection is required by user.

## Sketch Drawing and Mounting Dimensions Diagram (mm)

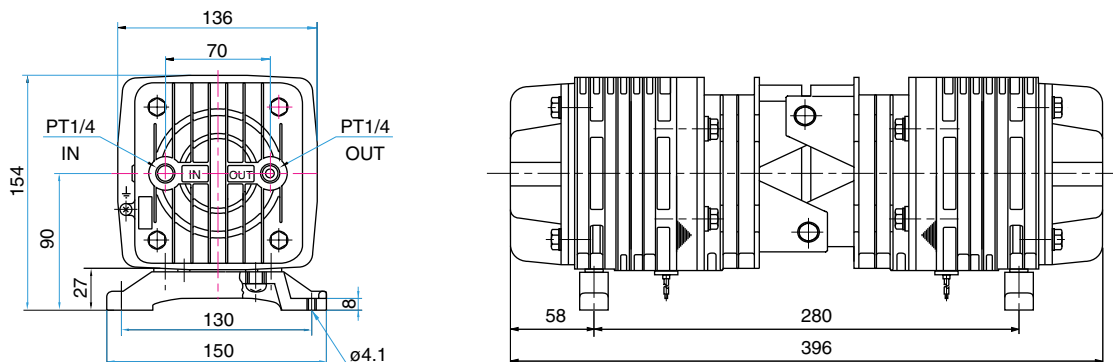

# DIAPHRAGM PUMP

## DIAPHRAGM PUMP



# vc0101s Dual Type

### Airflow & Power Consumption

### Specifications

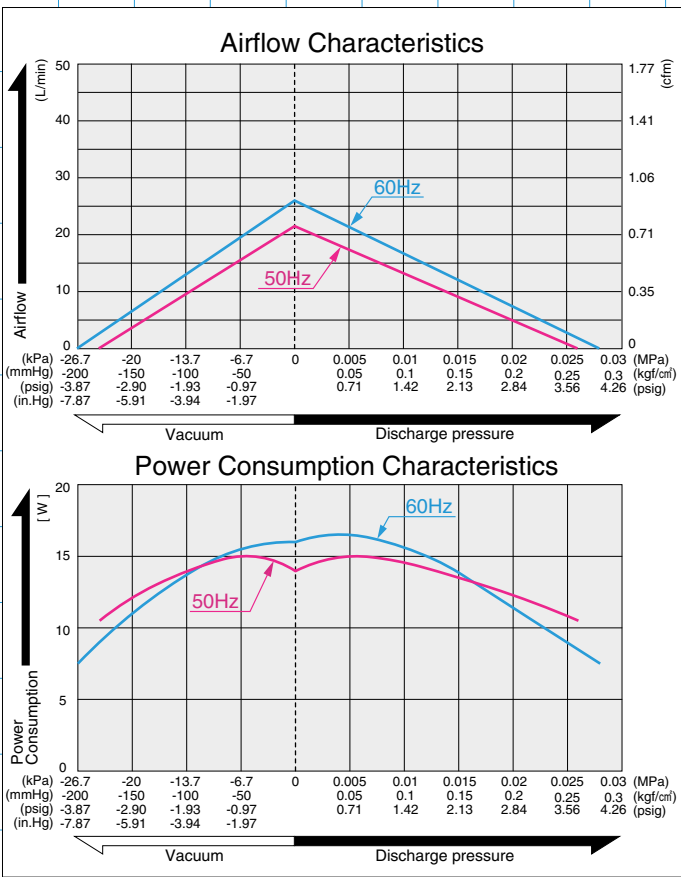

VC0101S	(SI)	(EURO)	(U.S.A.)
Rated Pressure	0.005 MPa {0.05 kgf/cm <sup>2</sup> }	0.05 bar	0.71 psig
Rated Airflow	15 L/min		0.53 cfm
Rated Voltage	120 V AC <sup>※1</sup> or 230 V AC		
Maximum Pressure	0.026 MPa {0.26 kgf/cm <sup>2</sup> }	0.26 bar	3.70 psig
Maximum Vacuum	-24 kPa {-180mmHg}	-240 mbar	-7.08 in.Hg
Power Consumption	15W		
Rated Frequency	60 Hz or 50 Hz		
Life Expectancy	5,000 hours		
Working Pressure Range	-24kPa~0.026 MPa {-180mmHg~0.26 kgf/cm <sup>2</sup> }	-240 mbar~ 0.26 bar	-7.08 in.Hg~3.70 psig
Outlet (Inlet)	7.5 mm O.D. hose nipple		
Duty Cycle	60 minutes		
Coil Insulation Class	B or its equivalent (JETL)		
Mounting Dimensions	66 (L) x 100 (W) mm	2-19/32"(L) x 3-15/16"(W)	
Gross Weight	0.82 kg	1.8 Lbs.	
Leadwire Length	300 mm	11-13/16"	

※1: 120V AC UL version is unavailable.  
Please read the page of "How to Use This Catalog" first for correct use of compressors and pumps.

### Application Examples

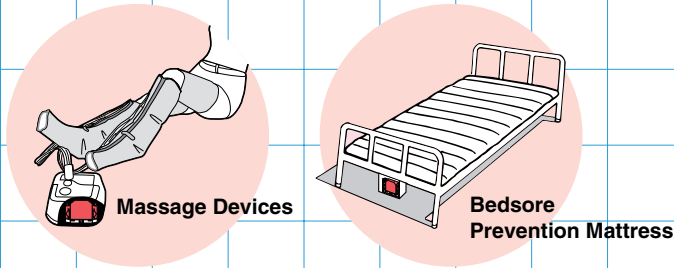

### Sketch Drawing and Mounting Dimensions Diagram (mm)

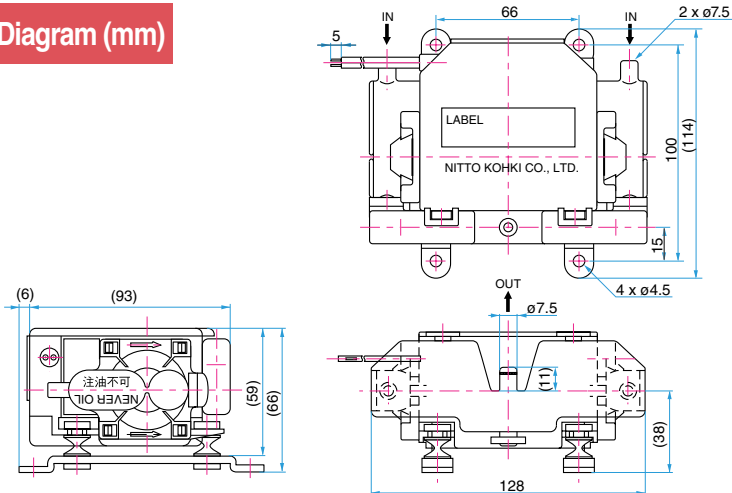

# DIAPHRAGM PUMP

## DIAPHRAGM PUMP



# vc0101s Blower Type

### Airflow & Power Consumption

### Specifications

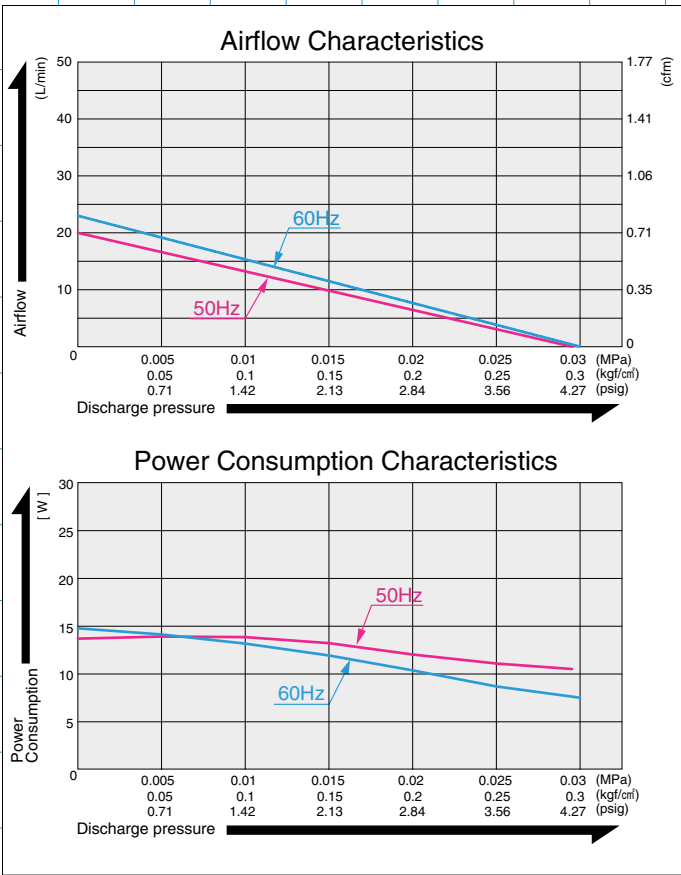

VC0101S	(SI)	(EURO)	(U.S.A.)
Rated Pressure	0.005 MPa (0.05 kgf/cm <sup>2</sup> )	0.05 bar	0.71 psig
Rated Airflow	15 L/min		0.53 cfm
Rated Voltage	120 V AC <sup>※1</sup> or 230 V AC		
Maximum Pressure	0.026 MPa (0.26 kgf/cm <sup>2</sup> )	0.26 bar	3.70 psig
Power Consumption	14W		
Rated Frequency	60 Hz or 50 Hz		
Life Expectancy	5,000 hours		
Working Pressure Range	0~0.026 MPa (0~0.26 kgf/cm <sup>2</sup> )	0~0.26 bar	0~3.70 psig
Outlet (Inlet)	7.5 mm O.D. hose nipple		
Duty Cycle	60 minutes		
Coil Insulation Class	B or its equivalent (JETL)		
Mounting Dimensions	66 mm(L) x 100 mm(W)	2-19/32"(L) x 3-15/16"(W)	
Gross Weight	0.83 kg	1.8 Lbs.	
Leadwire Length	300 mm	11-13/16"	

※1: 120V AC UL version is unavailable.  
Please read the page of "How to Use This Catalog" first for correct use of compressors and pumps.

### Application Examples

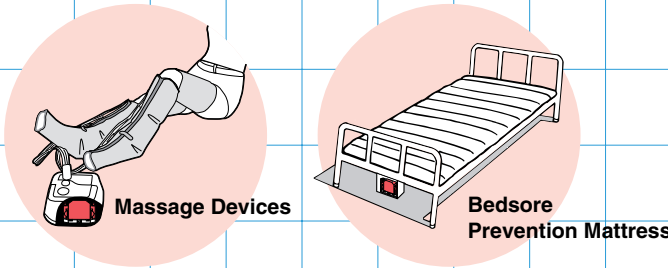

### Sketch Drawing and Mounting Dimensions Diagram (mm)

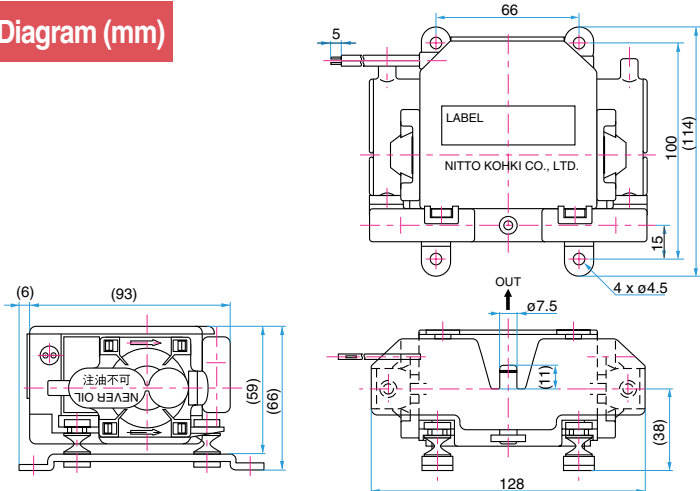



# FACTORIES

Six production bases support our flexible supply system with reliable quality and competitive costs.



TOCHIGI NITTO KOHKI CO., LTD.



UNIVERSAL DRILLING & CUTTING EQUIPMENT LTD.



MEDOTECH CO., LTD.



NITTO KOHKI - MIJIN CO., LTD.



SHIRAKAWA NITTO KOHKI CO., LTD.



NITTO KOHKI (THAILAND) CO., LTD.



NITTO KOHKI COUPLING (THAILAND) CO., LTD.



NITTO KOHKI AUSTRALIA MFG PTY LTD





**NITTO KOHKI's**

# Air Compressors & Vacuum Pumps



## Overseas Affiliates/Offices

### **MEDO U.S.A., INC.**

TEL:+1-630-924-8811 FAX:+1-630-924-0808  
<http://www.medousa.com/en/>

### **NITTO KOHKI EUROPE CO., LTD. (UK)**

TEL:+44-1923-239-668 FAX:+44-1923-248-815  
<http://www.nitto.co.uk/>

### **NITTO KOHKI DEUTSCHLAND GMBH**

TEL:+49-7157-22436 FAX:+49-7157-22437  
<http://www.nitto-kohki.de/>

### **NITTO KOHKI AUSTRALIA PTY. LTD.**

TEL:+61-7-3340-4600 FAX:+61-7-3340-4640  
<http://www.nitto-australia.com.au/>

### **NITTO KOHKI CO., LTD. SINGAPORE BRANCH**

TEL:+65-6227-5360 FAX:+65-6227-0192  
<http://www.nitto-kohki.co.jp/e/nksb/>

### **NITTO KOHKI CO., LTD. BANGKOK REPRESENTATIVE OFFICE**

TEL:+66-2-632-0307 FAX:+66-2-632-0308  
[http://www.nittobkk.com/eng\\_index.htm](http://www.nittobkk.com/eng_index.htm)

### **NITTO KOHKI CO., LTD. SHANGHAI REPRESENTATIVE OFFICE**

TEL:+86-21-6415-3935 FAX:+86-21-6472-6957  
<http://www.nitto-kohki.cn/>

### **NITTO KOHKI CO., LTD. SHENZHEN REPRESENTATIVE OFFICE**

TEL:+86-755-8375-2185 FAX:+86-755-8375-2187  
<http://www.nitto-kohki.cn/>

★ Specifications and designs are subject to change at any time without notice.



**NITTO**  
NITTO KOHKI CO.,LTD.

### **Head Office**

9-4, Nakaikegami 2-chome,  
Ohta-ku, Tokyo 146-8555 Japan  
Phone : +81-3-3755-1111 Fax : +81-3-3753-8791

- ▶ E-mail : [overseas@nitto-kohki.co.jp](mailto:overseas@nitto-kohki.co.jp)
- ▶ URL : [www.nitto-kohki.co.jp/e](http://www.nitto-kohki.co.jp/e)

**DISTRIBUTED BY**