

Blower

Model LA-60ECO & LA-80ECO

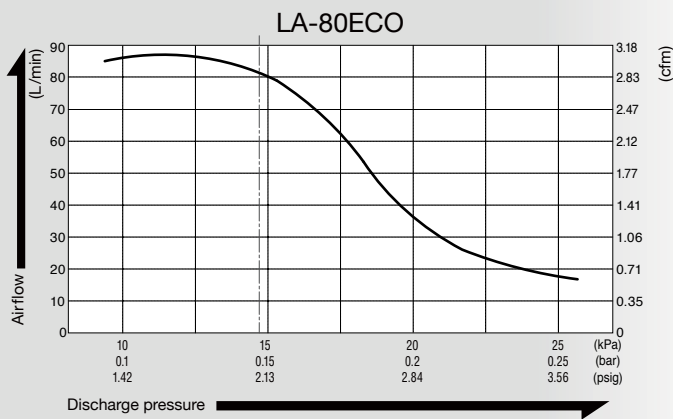

Airflow Characteristics

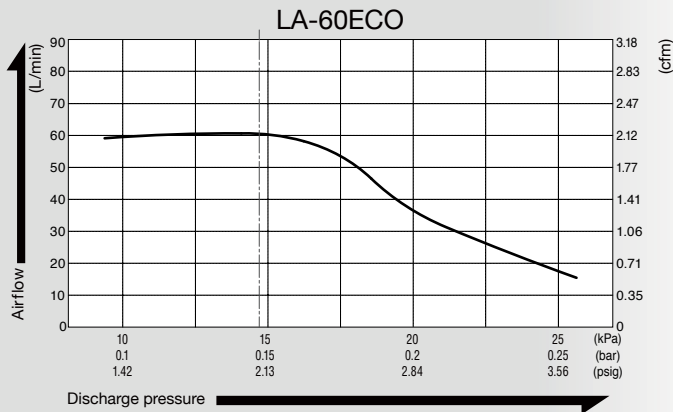

Specifications

	LA-60ECO	LA-80ECO
Power Supply	230 V AC *	
Rated Frequency	50 Hz	
Power Consumption	35 W	51 W
Rated Pressure	15 kPa (0.15 kgf/cm ²) 0.15 bar 2.13 psig	
Rated Airflow	60 L/min 2.12 cfm	80 L/min 2.83 cfm
Weight	4.3 kg 9.5 lbs	6.1 kg 13.4 lbs

*Only available in 230V
Please read the page of "How to Use This Catalog" first for correct use of compressors and pumps.

Optional Hose Assemblies



Application Examples

Liquid Mixer Bubbling

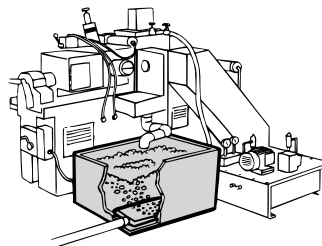

Home Aerobic Sewage Treatment System

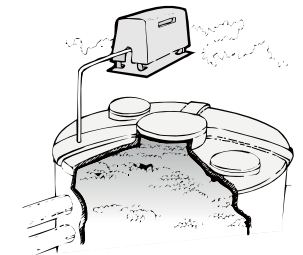

Dimensional Outline Drawing (Unit: mm)

LA-60ECO

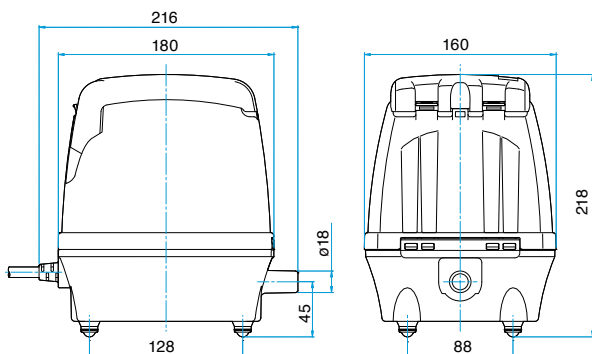

LA-80ECO

