

INSTRUCTION MANUAL

PNEUMATIC ANGLE GRINDER

Please read this manual carefully before you attempt to use your tool so that you may use it properly and safely.

MYTON
PROFESSIONAL TOOL

Model MLG-25

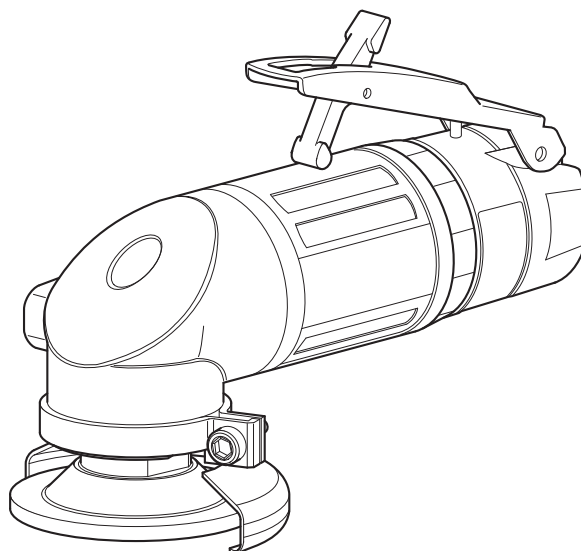

Specifications

Model		MLG-25	
Rated Air Pressure	MPa	0.6	
Air Consumption (No Load)	m ³ /min	0.42	
Rated Speed (No Load)	min ⁻¹ (r/min)	19,000	
Depressed Center Grinding Wheel	Diameter	mm(inch)	58 (2-9/32)
	Hole	mm(inch)	9.6 (3/8)
Mass (Weight)	kg	0.6	
Sound Pressure Level	dB(A)	90	
Sound Power Level	dB(A)	95	
Vibration Level	m/s ²	1.8	
Thread size of Air Inlet		Rc1/4	

Due to continuous product development/improvement the specifications and configurations in this document are subject to change without prior notice.



Manufactured by :

NITTO KOHKI Co., Ltd.
2-9-4, Nakaikegami, Ohta-ku,
Tokyo, 146-8555, Japan
TEL : (81)-3-3755-1111
FAX : (81)-3-3753-8791
E-mail : overseas@nitto-kohki.co.jp
URL : www.nitto-kohki.co.jp

Keep the manual handy – so you can use it whenever necessary.

Original Instructions

Thank you very much for your purchase of this **Nitto Kohki product**.

Before using your tool, please read this manual carefully so that you may use it properly to get the most out of it.

Please keep the manual handy - so you can use it whenever necessary.

- **English** : Please ask your dealer or distributor for instruction manual in local language(s).
- **German** : Bitte fragen Sie Ihren Händler nach eine Betriebsanleitung in Landessprache.
- **French** : S'il vous plait, veuillez demandez à votre fournisseur de manuel instruction en langue locale.
- **Spanish** : Por favor, contacte con su distribuidor para el manual de instrucciones en español.
- **Portuguese** : Por favor pessa ao seu agente ou distribuidor o manual de instruções em linguagem local.
- **Italian** : Per Manuale Istruzioni in lingua locale Vi preghiamo di rivolgerci al rivenditore o distributore.
- **Dutch** : Vraag uw handelaar om een nederladstalige gebruiksaanwijzing.
- **Swedish** : Be er lokala Åtreförsäljare eller distributör om manualer på svenska.
- **Danish** : Venligst henvend Dem til den danske distributør for instructions manualer.
- **Polish** : Proszę pytać swojego dealera lub dystrybutora o instrukcje obsługi w języku lokalnym.
- **中文** : 請向當地供應商或經銷商詢問中文使用說明書

CONTENTS	page
IMPORTANT SAFETY INSTRUCTIONS	2
GENERAL: TOOLS	2
GENERAL: PNEUMATIC TOOLS	3
INSTRUCTIONS FOR THIS TOOL	4
1. USAGE	5
2. CHECK THE CONTENTS OF THE PACKAGE	5
3. AIR SUPPLY	5
4. GRINDING WHEELS	5
5. MOUNTING AND DISMOUNTING GRINDING WHEEL ...	6
6. HOW TO OPERATE THE TOOL	6
7. STORAGE	7
8. MAINTENANCE	7
9. ORDERING SERVICE PARTS	7
10. EXPLODED DIAGRAM : MLG-25	8

PICTOGRAM



Warning: It might be dangerous to operate the tool if the instructions supplied are not followed.



Using this tool improperly could result in serious injury. Read the instruction manual before using.



Always wear suitable eye protection.



Always wear suitable hearing protection.



Always wear respiratory protective equipment (PPE).

The following Safety notations are used throughout the manual to highlight safety precautions for the user and for the tool.



WARNING:

Indicates a potentially hazardous situation which, if not avoided by following the instructions given, could result in death or serious injury.



CAUTION:

Indicates a potentially hazardous situation which, if not avoided by following the instructions given, could result in injury or material damage.

Please note, however, that failure to observe safety precautions under the “**Caution**” category could result in a serious occurrence depending on the situation: please observe all safety precautions in the manual.

Caution: Important precautions for tool setup, operation and maintenance.

IMPORTANT SAFETY INSTRUCTIONS

When using the tool, please observe the safety precautions below to prevent possible accident or injury.

GENERAL: TOOLS

WARNING

TO OPERATORS

- **Wear proper clothing for the type of work being done.**
Take care to avoid entanglement with the moving parts of the tool with clothing, ties, hair etc. If items become entangled it will cause the operator to be pulled towards the tool and lead to possible cause of accident or injury.
- **Always wear suitable eye protection.**
Remember, regular glasses are not safety glasses. The lenses are only shock resistant, which will not give you sufficient eye protection you may need in your working environment.
- **Always wear suitable hearing protection.**
- **Wear respiratory protective equipment (PPE).**
Wear respiratory protective equipment (PPE) when working in an environment where dust particles are generated in operation.
- **Avoid working posture that is too stressful.**
Always ensure a firm footing and well balanced posture.
- **Do not operate the tool if you are too tired.**
- **Never touch any moving parts of the tool when running.**

ABOUT WORK AREA

- **Keep the work area clean.**
Cluttered work areas (e.g. workbench) invite accidents.
- **Carefully select the work area.**
Do not expose tool to rain.
Do not use tool in a wet or soaked area.
See that the work area is adequately illuminated.
- **Never work near inflammable liquid or in a potentially explosive atmosphere.**
- **Keep children away from the work area.**
Keep children and unauthorized people away from the work area to avoid accident or injury.

BEFORE OPERATION

- **Inspect tool before use.**
Before using, check that screws are securely tightened, that any protective cover or guard is securely in place, other parts are free from damage and that the tool runs as it should.
Check that moving parts are properly adjusted for positioning and tightened, that parts are free from damage and properly mounted, and that all other parts are in good condition for normal operation.
Should you find any damage to the protective cover or other part, replace it in accordance with the Operation Manual. If there are no instructions in the Manual, please contact the sales agent through which you have purchased your tool or an authorized dealer near you for repair.
Likewise, if a switch failure occurs, contact sales agent through which you have purchased your tool or an authorized dealer near you for repair.
Do not use the tool if it does not start or stop with the start/stop switch.
- **Securely mount cutter**
An improperly mounted cutter may fly out, causing possible damage to the tool or injury to the operator.
- **Always remove spanner, wrench, etc., once adjustment has been made with them.**
- **Use a tool appropriate for the application.**
Avoid heavy-duty application that is beyond the capacity of tool.
- **Do not use the tool for purposes other than what it is designed for.**
- **Do not abuse tool.**
Use tool in accordance with the specifications: you'll get the most out of it while ensuring safety.
- **Securely fasten workpiece in place.**
Use a vice or clamp to securely fasten the workpiece in place. It is much safer this way than holding it in your hand, allowing you to operate the tool with both hands.

ABOUT HANDLING

- **How to store tool.**
When the tool is not used, store it in a dry area and out of reach of children.
- **How to carry tool.**
Do not touch the start switch while the tool is being carried.
- **Do not leave the tool unattended while it is running.**
Turn off the start switch and disconnect the tool from power source. Do not leave the work area until the

tool comes to a complete stop.

MAINTENANCE/SERVICE

- **Do not take apart or modify tool.**

Disassembly or modification carried out without the supervision of a qualified or authorized service engineer could result in an accident or injury.

- **Inspect cutting tool and accessories, etc.**

Always check to see that cutting tool and accessories, etc. are in good operating condition without damage or deterioration before you mount them on the tool. Should you find any damage to an accessory or part, please contact sales agent through which you have purchased your tool or an authorized dealer near you for repair.

- **Check parts for damage.**

When you have found damage to accessory or other part, carefully check the damaged part to determine the extent of influence it has upon the functions of the tool – that is, determine whether it can still perform its normal functions.

Check to see that the linkage of the moving parts is OK, that all parts are OK without damage, that they are properly mounted, and that the tool functions normally. Should you find any damage to an accessory or part that may hamper proper functioning of the tool, please contact sales agent through which you have purchased your tool or an authorized dealer near you for repair.

- **Have your tool repaired at an authorized Nitto Service Center.**

For repair or parts replacement, please contact the sales agent through which you have purchased your tool or an authorized dealer near you.

- **Use only Nitto genuine parts.**

Use of improper parts may result in serious occurrence.

To obtain a Nitto genuine part, consult this Manual or contact the sales agent from which you have purchased your tool directly.

- **Do not detach label or nameplate from tool.**

When a label/nameplate gets damaged, worn or becomes missing, contact the sales agent through which you have purchased your tool or Nitto Kohki Co. Ltd, directly for a replacement.

DISPOSAL

- When a tool is taken permanently out of service, it is advised that the tool is disassembled, degreased and parts separated by material and recycled locally in the appropriate manner.

GENERAL: PNEUMATIC TOOLS

WARNING

- **Use appropriate air pressure.**

Excessively high air pressure will increase the number of revolutions or strokes causing not only potential premature failure/breakage but could also lead to an unexpected accident or injury.

- **Connect tool to air supply line.**

There are various types of pipes running in a factory in addition to the pneumatic line (such as oxygen, nitrogen, gas and water). For this reason, always ensure that you are connecting to the pneumatic line.

- **Start tool properly.**

Turn the start switch OFF before connecting to the air supply line.

- **Always disconnect the tool from the air supply line before putting on/taking off any accessory and prior to carrying out any maintenance work.**

- **Avoid exposure to exhaust air.**

Pneumatic tool exhaust air contains oil and contaminated moisture. Make sure the exhaust air is not directed towards your face or anyone else within the work area.

- **Keep tool off electricity.**

This pneumatic tool is not electrically insulated. To avoid a potential electric shock do not use where there is a possibility of coming into contact with live electricity.

CAUTION

- **Handle tool carefully.**

Abusive use of tool could invite failure or accident. Do not throw, drop or shock the tool.

- **Handle connecting hose carefully.**

Do not carry the tool by the air hose. Do not pull the air hose to disconnect.

INSTRUCTIONS FOR THIS TOOL

About Your Tool

WARNING

- **Protect your body from the chips/filings.**
Hot chips/filings may fly out from the work piece. Always wear safety glasses, dust mask, earplugs, gloves (except knitted gloves) and long-sleeved garment.
Keep your face well away from the work piece.
- **Do not use any Grinding Wheel with the rated speed (r/min) that is lower than the actual no load speed of the grinder. Make sure the dimensions of the Grinding Wheel you are using is applicable to the specification of the grinder.**
- **Make sure there are no cracks, chips or damage to the Grinding Wheel prior to use. Do not use any wheels wet or without labels.**
- **Use Nitto Kohki's Wheel Flanges only. However, do not use any of them which have cracks, chips or worn. Do not use the alternative flanges or flat washers.**
- **Make sure if the Grinding Wheel is adaptable to the Wheel Flanges.**
Do not use reducing bushing to meet the Wheel Lock unless they are supplied by the Grinding Wheel manufacturer.
- **Make sure there are no cracks, distortion or wear marks on the thread of the Spindle or Wheel Lock.**
The label on the wheel has to be the same or bigger diameter than that of a Spindle.
- **Make sure if there is any cracks, distortion or worn on a thread of a Spindle or Wheel Lock.**
Do not use the grinder if you ever find one.
- **Do not use the side of the Grinding Wheel (except for specific side use Grinding Wheels)**
- **Always use the Wheel Guard for the grinder if the maximum diameter of the Grinding Wheel is over 50mm.**
- **Use the Wheel Guard provided.**
Failure to do so could result in injury.
- **Replace damaged, bent or severely worn Wheel Guard. Do not use any Wheel Guard which can damage the Grinding Wheel.**
- **Air pressure for the grinder must not exceed 0.6MPa (6kgf/cm²).**

- **Do not start or stop grinders suddenly.**
Open a Throttle Lever gradually when you start operation.
- **After a grinder has been repaired and returned, check the no load speed with a tachometer before you use to make sure its actual speed at 0.6MPa (6kgf/cm²) does not exceed the rated speed printed on the Wheel Guard. Do the same check after each stage of the work process of work even in normal use. Set the Adjust Valve to the maximum speed position when you check the no load speed.**
- **Only qualified/trained operators should attach or replace Grinding Wheels as well as checking/testing them.**
- **Release the Throttle Lever when air supply is stopped.**
- **Make sure no one is around grinding circumferences before trial running.**
- **Run a trial for a minute before start grinding and for three minutes after replacement of Grinding Wheels to make sure there is no problem on the grinder.**
- **Grind slowly until the Grinding Wheels get warmer in case Wheels seem cold at the start.**
- **Always operate the grinder at the correct angle. (15°~30°) . (Fig.1)**

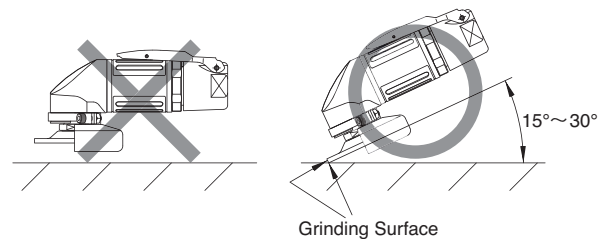

Fig. 1

- **Do not put any inflammable liquid or use the grinding tool in a potentially explosive atmosphere as there is a possibility of sparks when grinding which could cause a fire/explosion.**

1. USAGE

This tool is for grinding workpieces using a Type 27 Depressed Center Grinding Wheel.

2. CHECK THE CONTENTS OF THE PACKAGE

Check the contents and make sure that the tool does not have any damage which may have occurred during transportation. The contents should correspond to the list as follows. In case of damage/missing parts, please contact the sales agent from whom you purchased the tool.

Package Contents	Qty	Check
MYTON MLG-25	1	
Grinding Wheel GS #80	1	
Hex. Socket Screw Key 5	1	
Single Ended Spanner 19	1	
Bushing R1/4xNPT1/4	1	
Instruction Manual	1	
Declaration of Conformity	1	
Caution for Use	1	

3. AIR SUPPLY

3-1. Air Pressure

Adjust air pressure with the air regulator to the appropriate level for the pneumatic tool used.

Air pressure that is too low will stop the tool from operating at full capacity.

Air pressure that is too high may cause damage to the tool.

3-2. Air Line (Fig.2)

Use a 9.5 mm (3/8") I.D. connecting hose between the compressor and the tool.

Drained water, etc., if flown into the tool, could cause tool failure. Install an air filter between the compressor and the tool.

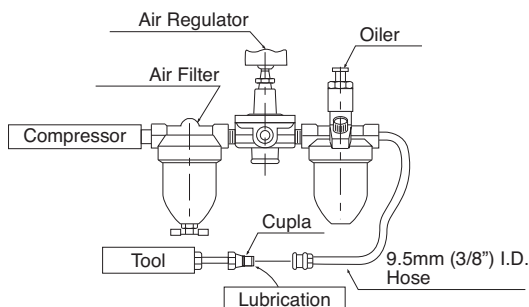

Fig. 2

3-3. Lubrication

Install an oiler between the compressor and the tool. Use the machine oil ISO VG-10. Failure to lubricate

as required may result in damage to the tool. Use of oil that is too thick will reduce the performance of the tool.

4. GRINDING WHEELS

! WARNING

The maximum operating speed marked on the Grinding Wheel, blotters, or packaging, shall equal or exceed the rated speed on the grinder.

Use with Type 27 Depressed Center Grinding Wheels.

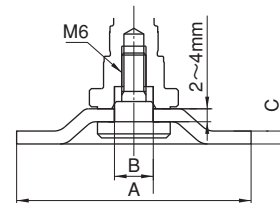

Fig. 3

	MLG-25
A	58mm (2-9/32")
B	9.6mm (3/8")
C	3mm (1/8")

A : Diameter of the Grinding Wheel

B : Hole of the Grinding Wheel

C : Thickness of the Grinding Wheel

5. MOUNTING AND DISMOUNTING GRINDING WHEEL

WARNING

Always turn off the air supply and disconnect the air supply hose.

Read and thoroughly understand **IMPORTANT INSTRUCTIONS FOR GRINDER** before carrying out these operations.

Mounting

- 1 Hold the Spindle with Spanner supplied.
- 2 Insert the Outer Flange into the Grinding Wheel.
- 3 Secure it firmly to the Spindle by tightening the Outer Flange with Hex. Socket Screw Key.

Removal

Hold the Spindle with Spanner and loosen Outer Flange with Hex. Socket Screw Key to remove the Grinding Wheel.

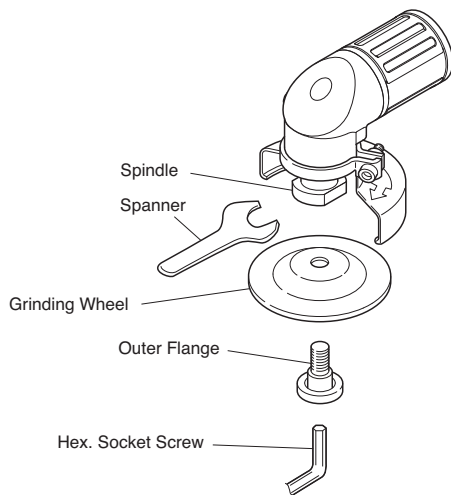

Fig. 4

6. HOW TO OPERATE THE TOOL

Start and Stop

To start, release the lock lever and grasp the throttle lever.

To stop, release the throttle lever.

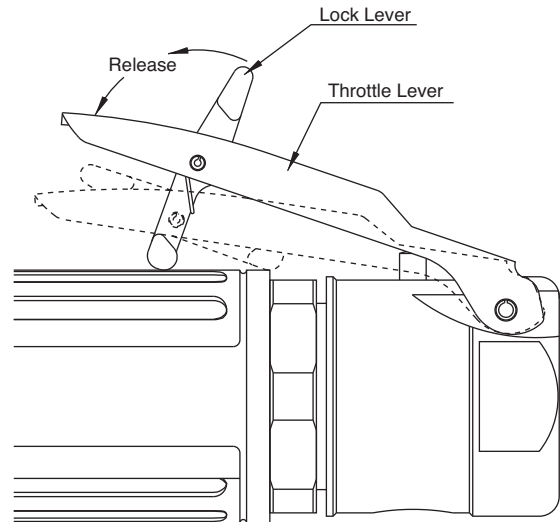

Fig. 5

Adjust Valve

WARNING

Be sure to keep hands clear of moving parts.

The desired number of rotation between maximum rpm and minimum rpm is obtained by turning the groove of valve clockwise or counterclockwise with screwdriver.

Maximum rotation

Position the groove of Adjust Valve horizontal to main body.

Minimum rotation

Position the groove of Adjust Valve vertical to main body.

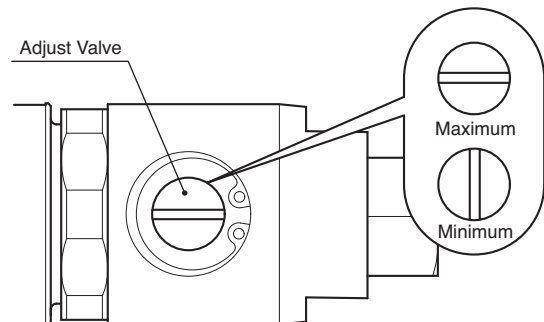

Fig. 6

7. STORAGE

CAUTION:

When tool is not used, store it out of reach of children.

Avoid storing the tool in a location subject to high humidity. If the tool is left as it is used, residual moisture on the inside can cause rusting. Before storing, and after operation, oil the tool at the air inlet with machine oil ISO VG-10 and run it for a short time.

8. MAINTENANCE

Supply additional appropriate amount of SUMICO Sumitec 305 Grease into the Gear Case with about once a month interval.

1. Loosen the Screw 4x12 and remove the Exhaust Cover, the Toothed Washer CW-4, the Spacer, the Exhaust Plate, and the Packing Cover.
2. Inject grease with a grease gun into the Grease Port next to the Exhaust Port.
The outside diameter of the nozzle tip of the grease gun must be 3mm or smaller. The nozzle for grease nipple cannot be used for this grease filling, because the shape of the Grease Port is different from that of the nozzle for grease nipple.
3. Before putting back the Exhaust Cover, execute idle running and wipe out excessive grease.
4. For assembly, see Fig.8 and put back the parts in the reverse order of disassembly.

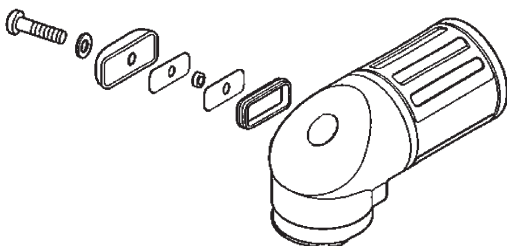
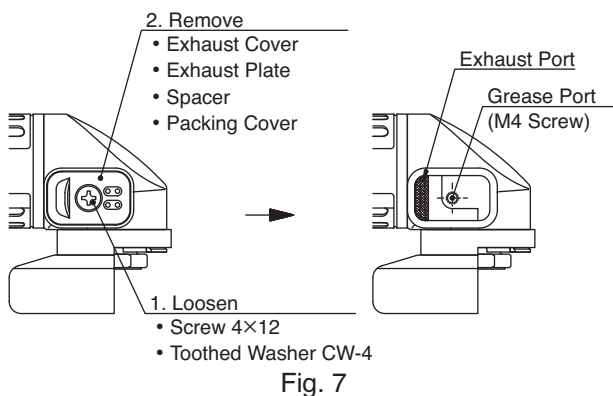

9. ORDERING SERVICE PARTS

- For further operational and handling information or for replacement of parts and components, contact the company from whom you purchased the tool or an authorized dealer.
- In ordering parts and components give each part number, part name and quantity required.
- Use only NITTO genuine parts.

10. EXPLODED DIAGRAM : MLG-25

⚠ WARNING

This diagram is for your reference only. Do not attempt to service or repair the Tool.

Do not take the Tool apart. Contact an authorized Nitto dealer for all service and repair of the Tool.

Improper service and repair can cause accidents and service injuries.

Never attempt to modify the Tool.

Never attempt service or repair the Tool yourself.

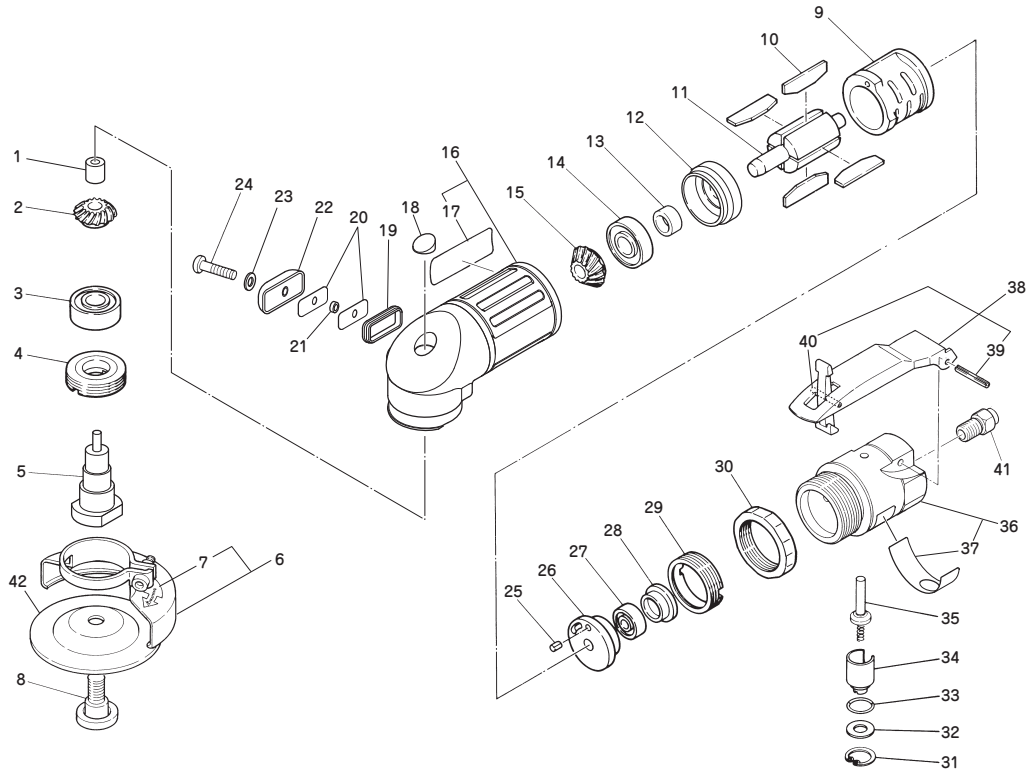

The part numbers with () are included in the Ass'y parts written above them.

No.	PartsNo.	Description	Qty	Price
1	TQ12638	Needle Bearing BK0609T2	1	
2	TQ12986	Gear 1x22	1	
3	TP00498	Ball Bearing 6001ZZ	1	
4	TB08597	Bearing Set Screw Ass'y	1set	
5	TQ12620	Spindle	1	
6	TB08893	Wheel Guard Ass'y	1set	
7	(TQ13054)	Label Warning Wheel Guard	1	
8	TP17962	Disk Lock	1	
9	TP14222	Cylinder	1	
10	TB08602	Blade Ass'y (4 pcs.)	1set	
11	TP14224	Rotor	1	
12	TQ12622	End Plate B	1	
13	TP06322	Spacer 8x11x3	1	
14	TP00468	Ball Bearing 608ZZ	1	
15	TQ12985	Pinion 1x15	1	
16	TB08892	Housing Ass'y	1set	
17	(TQ13052)	Label Warning CE Mark	1	
18	TQ12628	Plug	1	
19	TQ12649	Packing Cover	1	
20	TQ12630	Exhaust Plate	2	
21	TQ12658	Spacer 4EP-3	1	
22	TQ12629	Exhaust Cover	1	
23	TQ12647	Toothed Washer CW-4	1	
24	TQ12739	Raised Countersunk Head Screw 4x12	1	

No.	PartsNo.	Description	Qty	Price
25	TP00496	Spring Pin 2.5x6 AW	1	
26	TP10109	End Plate A	1	
27	TP03933	Ball Bearing 606ZZ	1	
28	TP10110	Cap	1	
29	TP10098	Lock Nut	1	
30	TP03468	Lock Ring	1	
31	TP03695	Internal Retaining Ring C-12	1	
32	TP06326	Spacer 6x12x1.2	1	
33	TP11997	O-Ring KS-7	1	
34	TP06325	Adjust Valve	1	
35	TA93070	Valve Stem Ass'y	1set	
36	TB08895	Valve Body Sub Ass'y	1set	
37	(TQ13053)	Label Model	1	
38	TB01152	Lever Ass'y	1set	
39	(TP00460)	Spring Pin 3x22 AW	1	
40	(TP05498)	Spring Pin 2x16 AW	1	

Accessories

No.	PartsNo.	Description	Qty	Price
41	TP02236	Bushing R1/4xNPT1/4	1	
42	-	Grinding Wheel GS#80x58	1	
	TQ12633	Single Ended Spanner 19	1	
	TP04004	Hex. Socket Screw Key 5	1	
	TQ13055	Instruction Manual	1	
	-	Declaration of Conformity	1	



■ Overseas Affiliates / Offices

Nitto Kohki U.S.A., Inc.

4525 Turnberry Drive, Hanover Park, IL 60133, U.S.A

Tel: (1)-630-924-9323 Fax:(1)-630-924-0303
<http://www.nittokohki.com/index.html>

Nitto Kohki Europe Co., Ltd.

Unit 21, Empire Centre, Imperial Way,
 Watford Hertfordshire, WD24 4TS, United Kingdom

Tel: (44)-01923-239668 Fax:(44)-01923-248815
<http://www.nitto.co.uk/>

Nitto Kohki Deutschland GmbH

Lerchenstr. 47, D-71144 Steinenbronn, Germany

Tel: (49)-7157-22436 Fax:(49)-7157-22437
<http://www.nitto-kohki.de/>

Nitto Kohki Australia Pty. Ltd.

77 Brandl Street, Eight Mile Plains QLD 4113,
 Australia

Tel: (61)-7-3340-4600 Fax:(61)-7-3340-4640
<http://www.nitto-australia.com.au/>

Nitto Kohki Co., Ltd. Singapore Branch

10 Ubi Crescent #01-62, Ubi Techpark Lobby D,
 Singapore 408564

Tel: (65)-6227-5360 Fax:(65)-6227-0192
<http://www.nitto-kohki.co.jp/e/nksb/>

Nitto Kohki Co., Ltd. Shanghai Representative Office

#1117 Ruijing Building, Maoming South Road,
 Shanghai 200020 China

Tel: (86)-21-6415-3935 Fax:(86)-21-6472-6957
<http://www.nitto-kohki.cn/>

Nitto Kohki Co., Ltd. Shenzhen Representative Office

#0726 International Culture Building, 3039, Shennan Zhong
 Rd., Futian District, Shenzhen, 518003 China

Tel: (86)-755-8375-2185 Fax:(86)-755-8375-2187
<http://www.nitto-kohki.cn/>

Nitto Kohki Co., Ltd. Bangkok Representative Office

38Q, House Convent Bldg, 7th Floor, Unit 7A,
 Convent Rd, Silom, Bangkok, 10500 Thailand

Tel: (66)-2-632-0307 Fax:(66)-2-632-0308
http://www.nittobkk.com/eng_index.htm

EC DECLARATION OF CONFORMITY

We hereby declare that the following our product conforms with the essential health and safety requirements of EEC Directives.

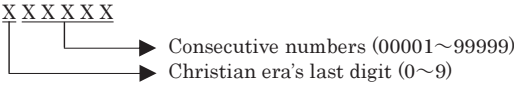
Product: PNEUMATIC ANGLE GRINDER
 Model: MYTON: MLG-25, MLG-40, MLG-70
 Serial No: X X X X X

 Manufacturer: NITTO KOHKI Co., Ltd.
 2-9-4, Nakaikegami, Ohta-ku, Tokyo, 146-8555, Japan
 Authorised Compiler In The Community:
 NITTO KOHKI EUROPE Co., Ltd.
 Unit21, Empire Centre, Imperial Way, Watford Hertfordshire, WD24 4TS, UK
 Tel:(44)-01923-239668 Fax:(44)-01923-248815
 Directive: 98/37/EC and 2006/42/EC Machinery Directive

The above product has been evaluated for conformity with above directives using the following European standards.

The technical construction file (TCF) for this product is retained at the above manufacturer's location.

Machinery Directive: EN ISO12100-1:2003, EN ISO12100-2:2003,
 EN ISO14121-1:2007, EN792-7:2001+A1:2008, others
 Sound Pressure/Power Level: EN ISO15744:2008, EN ISO4871:1996
 Vibration Level: EN28662-1:1992, EN ISO8662-4:1995
 Name: K.Kishi
 Title: GENERAL MANAGER MACHINE TOOLS DIV.

Being the responsible person appointed and employed the manufacturer.