

For High Pressure

350-G Cupla

For hydraulic pressures up to 350 bar



Their “airless valve shut-off design” greatly reduces air admixture! Ideal for hydraulic lines with larger pressure fluctuations.

- Locking mechanism to prevent accidental disconnection maintains tight connection even under vibration or impact.
- Both socket and plug have built-in automatic shut-off valves to prevent fluid spill out when disconnected. Easy to handle.

New!

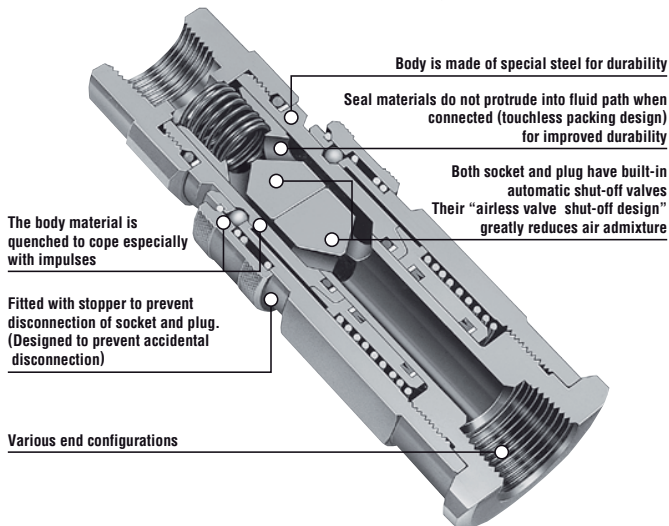

Specifications

Body material	Special steel (Nickel-plated)			
Size	1/4" • 3/8" • 1/2" • 3/4" • 1" • 1 1/4" • 1 1/2" • 2"			
Working pressure	bar	350		
Pressure resistance	bar	514		
Seal material Working temperature range	Seal material	Mark	Working temperature range	Remarks
	Fluoro rubber	FKM (X-100)	-20°C~+180°C	Standard material
	Nitrile rubber	NBR (SG)	-20°C~+80°C	Made-to-order item

Max. Tightening Torque

N·m (kgf·cm)

Size	1/4"	3/8"	1/2"	3/4"	1"	1 1/4"	1 1/2"	2"
Torque	28 {286}	40 {408}	80 {816}	150 {1530}	250 {2550}	500 {5100}	500 {5100}	700 {7140}

Flow Direction

Fluid may flow in either direction from plug or from socket side when coupled.

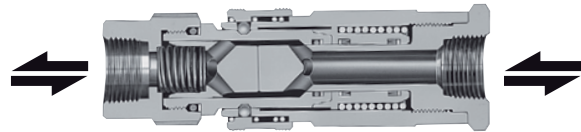

Interchangeability

Different size socket and plug cannot be connected each other. However, 350-2SP with 350-3SP or 350-10SP with 350-12SP can be connected each other.

Min. Cross-Sectional Area

(mm²)

Model	350-2SP	350-3SP	350-4SP	350-6SP	350-8SP	350-10SP	350-12SP	350-16SP
Min. cross-sectional area	32.2	32.2	78.5	149.6	227.0	452.4	452.4	907.9

Suitability for Vacuum

Not suitable for vacuum application in either connected or disconnected condition.

Admixture of Air on Connection

(mL)

Model	350-2SP	350-3SP	350-4SP	350-6SP	350-8SP	350-10SP	350-12SP	350-16SP
Volume of air	0.1	0.1	0.2	0.3	0.5	0.9	0.9	2.0

Flow Rate – Pressure Loss Characteristics

[Test conditions] • Fluid : Hydraulic oil • Temperature : 40°C± 5°C
• Fluid viscosity : 32 × 10⁻⁶m²/s • Density : 0.87 × 10³kg/m³

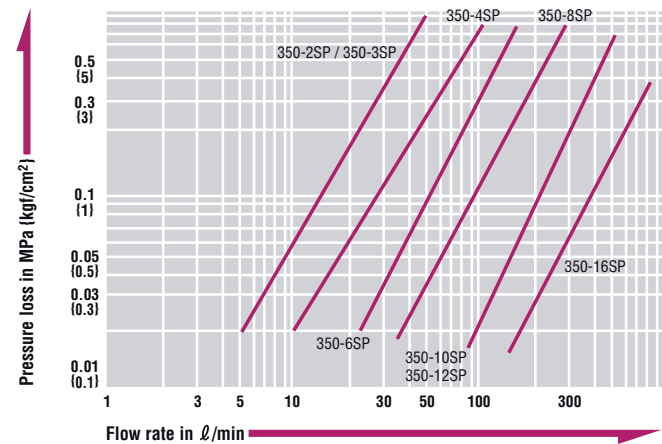

⚠ Precautions for use

Do not connect / disconnect Cuplas when pressure is applied or remaining.

Models and Dimensions

Plug Female thread

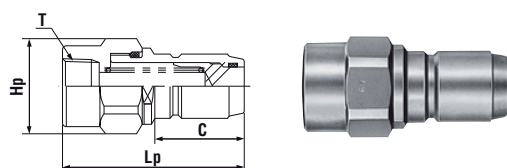

Model	Application	Mass (g)	Dimensions (mm)			
			Lp	C	Hp (WAF)	T
350-2P-2G*	BSP (G) 1/4	170	(74)	36	Hex.27 x ϕ 29	BSP (G) 1/4
350-3P-3G	BSP (G) 3/8	175	(74)	36	Hex.27 x ϕ 29	BSP (G) 3/8
350-4P-4G	BSP (G) 1/2	245	88	40.5	Hex.27 x ϕ 30	BSP (G) 1/2
350-6P-6G	BSP (G) 3/4	415	90	44.5	Hex.38 x ϕ 41	BSP (G) 3/4
350-8P-8G	BSP (G) 1	1,035	(123)	57	Hex.50 x ϕ 55	BSP (G) 1
350-10P-10G*	BSP (G)1 1/4	2,700	(144)	75	Hex.70 x ϕ 78	BSP (G)1 1/4
350-12P-12G*	BSP (G)1 1/2	2,600	(144)	75	Hex.70 x ϕ 78	BSP (G)1 1/2
350-16P-16G*	BSP (G) 2	7,500	(198)	85.5	90 x ϕ 105	BSP (G) 2

* Available on request

Socket Female thread

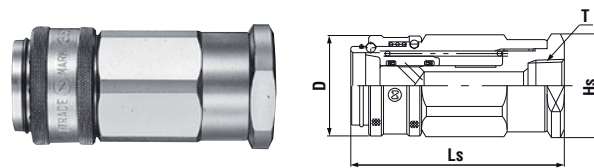

Model	Application	Mass (g)	Dimensions (mm)			
			Ls	ϕ D	Hs (WAF)	T
350-2S-2G*	BSP (G) 1/4	360	(82)	34	Hex.30	BSP (G) 1/4
350-3S-3G	BSP (G) 3/8	295	(82)	34	Hex.30	BSP (G) 3/8
350-4S-4G	BSP (G) 1/2	470	(96.5)	41	Hex.36	BSP (G) 1/2
350-6S-6G	BSP (G) 3/4	660	(105.5)	49	46 x ϕ 52	BSP (G) 3/4
350-8S-8G	BSP (G) 1	1,740	(133)	63	55 x ϕ 62	BSP (G) 1
350-10S-10G*	BSP (G)1 1/4	5,600	(180)	89	Hex.80 x ϕ 90	BSP (G)1 1/4
350-12S-12G*	BSP (G)1 1/2	5,500	(180)	89	Hex.80 x ϕ 90	BSP (G)1 1/2
350-16S-16G*	BSP (G) 2	14,500	(239)	117	105	BSP (G) 2

* Available on request

Application Example

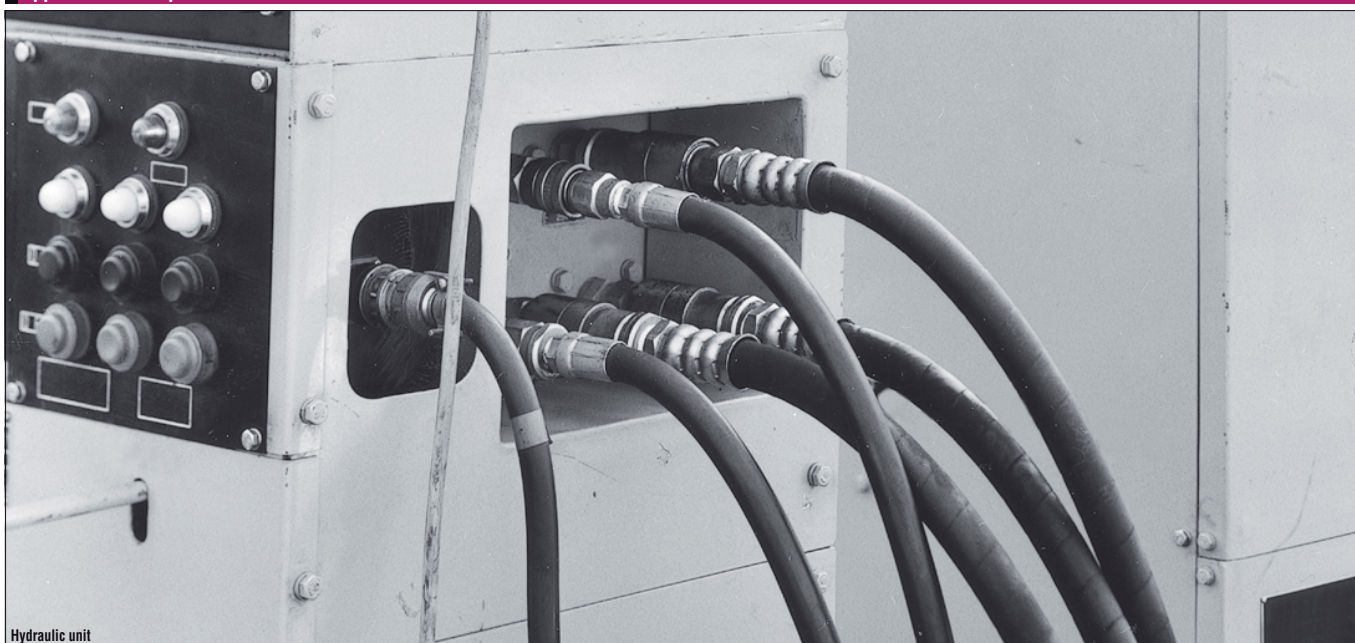

Hydraulic unit



NITTO
NITTO KOHKI CO.,LTD.

Head Office

9-4, Nakaikegami 2-chome,
Ohta-ku, Tokyo 146-8555 Japan
Phone : +81-3-3755-1111 Fax : +81-3-3753-8791

- ▶ E-mail : overseas@nitto-kohki.co.jp
- ▶ URL : www.nitto-kohki.co.jp/e

DISTRIBUTED BY

Nitto Kohki Deutschland GmbH

Lerchenstraße 47 • 71144 Steinbronn
GERMANY

Tel: +49 (0)7157 22436 • Fax: +49 (0)7157 22437

E-mail: info@nitto.de

<http://www.nitto.de>