

INSTRUCTION MANUAL

Professional tool Pneumatic Grinder

MYTON

Model: MYG-50

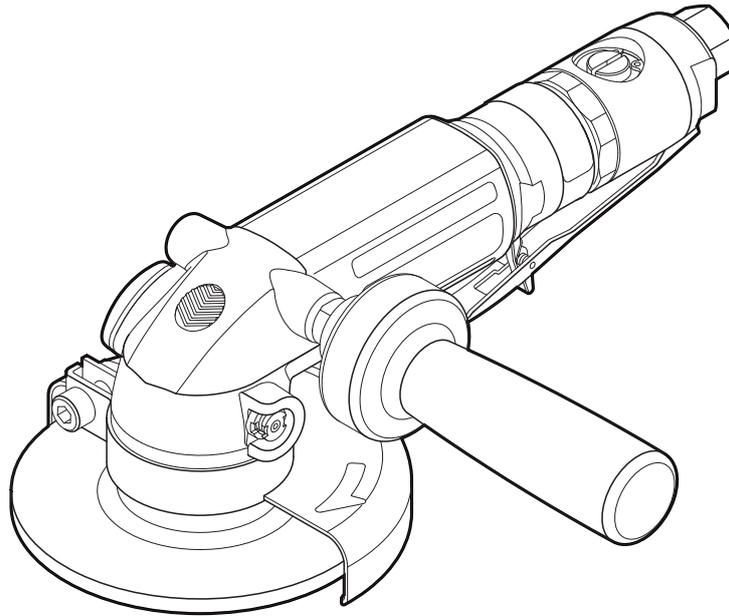

- The end tool in the drawing is not included with the tool.

[Specifications]

Model		MYG-50
Maximum operating pressure	MPa	0.6
Air consumption (No load)	m ³ /min	0.70
Rated speed (No load)	min ⁻¹	11000
Depressed Center Grinding Wheel outer diameter	mm (inch)	125 (5")
Depressed Center Grinding Wheel hole diameter	mm (inch)	22.2 (7/8")
Mass (weight)	kg	2.5
Sound pressure level *1	dB (A)	92
Sound power level *1	dB (A)	103
Vibration level *2	m/s ²	4.5 (Main unit) 4.2 (Side Handle)
Thread size of Air Inlet		Rc 3/8

*1 Based on the ISO15744 measurement standard.

*2 Based on the 3 axes combined value measurement standard of the ISO28927-1 of the hand-held tool frequency correction vibration acceleration effective value.

- Please read manual carefully before you attempt to use your tool so that you may use it properly and safely.
- Keep the manual handy - so you can use it whenever necessary.

- Due to continuous product development/improvement, the specifications and configurations in this document are subject to change without prior notice.

Manufactured by.

NITTO KOHKI CO., LTD.

9-4, Nakaikigami 2-chome, Ohta-ku, Tokyo, 146-8555, Japan
Tel : +81-3-3755-1111 Fax : +81-3-3753-8791

(Original Instructions)

TQ15279-0 12/2017

Instructions

Thank you very much for your purchase of this NITTO KOHKI product.
Before using your tool, please read this manual carefully so that you may use it properly to get the most out of it.
Please keep the manual handy - so you can use it whenever necessary.

- English : Please ask your dealer or distributor for instruction manual in local language(s).
- German : Bitte fragen Sie Ihren Händler nach eine Betriebsanleitung in Landessprache.
- French : S'il vous plait, veuillez demandez á votre fournisseur de manuel instruction en langue locale.
- Spanish : Por favor, contacte con su distribuidor para el manual de instrucciones en español.
- Portuguese : Por favor pessa ao seo agente ou distribuidor o manual de instrucces ih linguagen local.
- Italian : Per Manuale Istruzioni in lingua locale Vi preghiamo di rivolgervi al rivenditore o distributore.
- Dutch : Vraag uw handelaar om een nederladstalige gebruiksaanwijzing.
- Swedish : Be er lokala Åtreförsäljare eller distributör om manualer på svenska.
- Danish : Venligst henvend Dem til den danske distributør for instructions manualer.
- Polish : Proszę pytać swojego dealera lub dystrybutora o instrukcje obsługi w języku localnym.
- 中文 : 請向當地供應商或經銷商詢問中文使用說明書

The following Safety notations are used throughout the manual to highlight safety precautions for the user and for the tool.



WARNING:

Indicates a potentially hazardous situation which, if not avoided by following the instructions given, could result in death or serious injury.



CAUTION:

Indicates a potentially hazardous situation which, if not avoided by following the instructions given, could result in injury or material damage.

* Please note, however, that failure to observe safety precautions under the “ **CAUTION**” category could result in a serious occurrence depending on the situation.

Please observe all safety precautions in the manual.

CAUTION: Important precautions for tool setup, operation and maintenance.

About pictograms



WARNING:

It might be dangerous to operate the tool if the instructions supplied are not followed.



Using this tool improperly could result in serious injury. Read the instruction manual before using.



Always wear suitable eye protection.



Always wear suitable hearing protection.



Always wear respiratory protective equipment (PPE).

Contents

Precautions on Use (Make sure to follow the instructions given).....	2	6 How to Use.....	19
General Power Tool Safety Warnings	2	Grinding work.....	19
General Pneumatic Tool Safety Warnings	5	7 Maintenance and Inspection.....	20
Safety Warnings for PNEUMATIC GRINDER	5	Storing the tool.....	20
Product Specific Safety Rules.....	10	Storing the Grinding Wheel.....	20
1 Application	12	Maintenance and Inspection	20
2 Checking Inside the Package	12	Disposal	21
3 Part Names.....	13	8 Exploded View/Parts List.....	22
4 Air Supply	14	MYG-50 Exploded View/Parts List.....	22
5 Preparation	15		
Attaching the Wheel Guard Ass'y	15		
Attaching the Side Handle Ass'y	16		
Replacing the Grinding Wheel	17		
Start and stop.....	18		
Adjusting the rotation speed	18		

California Proposition 65

WARNING

Some dust created by power sanding, sawing, grinding, drilling, and other construction activities contains chemicals known [to the State of California] to cause cancer birth defects or other reproductive harm.

Some examples of these chemicals are:

- Lead from lead-based paints,
- Crystalline silica from bricks and cement and other masonry products, and
- Arsenic and chromium from chemically-treated lumber.

Your risk from these exposures varies, depending on how often you do this type of work. To reduce your exposure to these chemicals: work in a well ventilated area, and work with approved safety equipment, such as those dust masks that are specially designed to filter out microscopic particles.

Precautions on Use (Make sure to follow the instructions given)

Before using your tool, to avoid personal injury always take the basic precautions explained in later sections.

General Power Tool Safety Warnings

Personal safety

⚠ WARNING

- **Dress properly.**
Do not wear loose clothing or jewelry. There is a danger of being caught in moving parts. Wear a pair of non-slip shoes. If your hair is long, wear a protective hair covering to contain your hair.
- **Always wear eye protection.**
Corrective glasses are not considered eye protection. Always wear appropriate eye protection.
- **Wear a dust mask.**
When dust is generated in the workplace, wear a dust mask.
- **Use a dust collector or dust collection equipment correctly.**
If a dust collector or dust collection equipment are being used, check that these are connected and used properly. Use of a dust collector can reduce risk caused by dust.
- **When loud noise is generated in the workplace, wear a hearing protection.**
- **Do not overreach.**
Keep proper footing and balance at all times.
- **Be on your guard when working.**
Do not use the tool when you are tired.
When you use the tool, be sure about the handling method, how to work, and pay sufficient attention to the surrounding environment.
- **Never touch the tip of moving parts when the tool is running.**
Also, do not direct the tip of moving parts toward people or animals.
- **Be aware of tool vibration and recoil. Some tools can cause a considerable amount of vibration.**
Depending on how the product is operated, the type of tool setting, and the length of operation, it could place a tremendous burden on your hands, arms and body.
The tool could cause a vibration injury or tendonitis. Avoid long-term use and take appropriate breaks.
Consult a doctor if you experience any discomfort or pain while operating the tool.

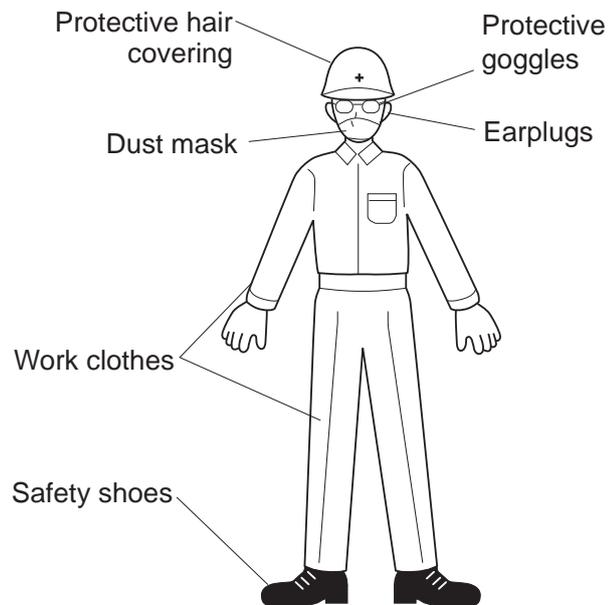

Work area safety

⚠ WARNING

- **Do not use the tool at home.**

This is a professional tool (industrial or work tool for business). Do not bring the tool home and use it there.

- **Keep the work area clean.**

Working in a messy work area or work table could cause an accident.

- **Be cautious about the work area.**

Do not expose the tool to rain.

Do not use the tool in a damp or wet place.

Keep the work area well lit.

- **Do not operate the tool in an explosive atmosphere, such as in the presence of flammable liquids (thinner, lacquer, gasoline, etc.) or gas.**

- **Do not let children come close to the work area.**

Keep children and bystanders away while operating tool.

- **Some tools generate loud noise.**

Check that the noise regulations of each area are complied with.

- **When work has to be done in high locations, make sure there is nobody underneath the work area.**

If the tool or material is dropped, it could cause an accident or injury.

- **Before starting operation, make sure that there is no conduit, water pipe or gas pipe by your work area.**

If a tool touches a buried object, it could cause electrical shock or leakage, which could cause an accident.

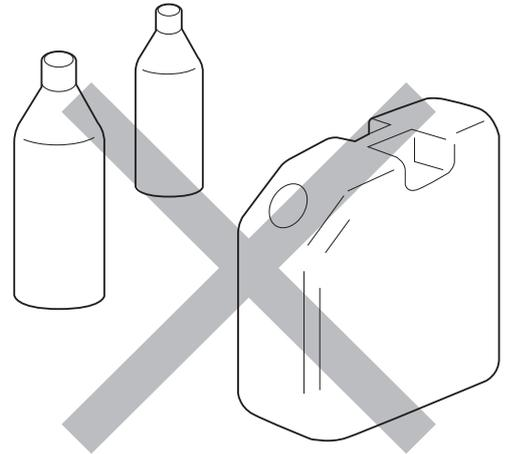

Before starting to work

⚠ WARNING

- **Perform inspection before using the tool.**

Before using the tool, check for loose screws on the tool and for damage on the protective cover or other parts, and make sure that the tool operates normally and demonstrates prescribed functions.

Check the position adjustment and tightening status of moving parts, parts damage, attachment status, and all other locations for issues that could affect operation.

For parts replacement and repair, follow the instructions indicated in the instruction manual.

If there are no instructions in the instruction manual, contact the retailer where you purchased the tool or the nearest NITTO service member store.

Do not use the power tool if the switch does not turn it ON and OFF.

- **Make sure to properly attach the tip tool.**

If the tip tool is not attached properly, there is a risk of jumping out or damage, which could result in injury.

- **After adjustment, be sure to remove tools such as spanners, wrenches, etc.**

- **Use appropriate tools.**

Do not force small tools to do the job of a heavy duty tool. Do not use tools for purposes not intended.

- **Do not use tools in an unreasonable manner.**

When the specifications are followed, tools can be used efficiently and safely.

- **Secure workpieces.**

Where possible use clamps or a vise to hold the work. It is safe to hold the workpieces by hand and both hands can be used for operation.

Handling tools

WARNING

- **Storing the tool**
When the tool is not used, store the tool in a dry location. Also, store the tool out of the reach of children. For some tools, the storage temperature and humidity are specified. Store the tool in an appropriate location.
- **Be cautious about how the tool is carried.**
Do not carry the tool with your hand touching the operation switch.
- **Do not leave the tool while the tool is still running.**
Do not leave the work area until you turn off the operating switch, remove the power source and the tool completely stops.
- **Do not allow the following chemicals to come into contact with the tool, as parts could deteriorate.**
Acetone, benzine, thinner, ketone, ether, trichloroethylene and other similar chemicals

Maintenance and Inspection

WARNING

- **Do not disassemble or alter the tool.**
Using the tool after disassembling or remodeling it could cause an accident or injury.
- **Inspect tip tools and accessories.**
Always inspect tip tools and accessories for damage or deterioration before attaching them to the tool. If damage or deterioration is found, request repair from the retailer where you purchased the tool or the nearest NITTO service member store.
- **Inspect for damaged sections.**
Sufficiently check for damage on accessories or other parts, that the tool operates normally, and that work can be performed appropriately.
If there are accessories or parts that have been damaged or could hinder work, request repair from the retailer where you purchased the tool or the nearest NITTO service member store.
- **Request repair from a dedicated store.**
For repair or replacement of parts, request service from the retailer where you purchased the tool or the nearest NITTO service member store.
Repair requires special knowledge and skills. If repair is performed at a place other than a specialty store, the tool may not demonstrate its full performance or it could lead to an accident or injury.
Request repair with the failed status kept intact. When requesting a repair, do not throw away damaged parts. It could be important information for investigating the failure cause so do not change the status.
- **Use genuine parts.**
If inappropriate parts are used, it could cause accident or injury.
Genuine parts are listed in the instruction manual or brochure. Inquire at the retailer where you purchased the tool or the nearest NITTO service member store.
- **Do not remove the labels or plates on the tools.**
If labels or plates are broken or peeling, for a replacement label or plate contact the retailer where you purchased the tool or the nearest NITTO service member store.

General Pneumatic Tool Safety Warnings

WARNING

- **Use the tool with proper air pressure.**
If the air pressure is high, the rotation speed and reciprocation frequency become faster, causing damage such as damage or accelerated wear. Also, unexpected accidents could occur.
- **Connect the tool to air piping.**
In some factories, other than air piping, there may be other piping such as oxygen, nitrogen, gas, etc. Before connecting to piping, make sure it is the correct piping.
- **Do not start the tool carelessly.**
Turn off the operation switch, then attach the Connecting Hose to the tool.
- **When attaching, removing, and maintaining accessories, make sure to detach the Connecting Hose from the tool.**
- **Be cautious about exhaust.**
Pneumatic tool exhaust contains oil and drainage, etc. Be careful about the exhaust direction so that the exhaust does not directly hit people nearby.
- **Do not allow sources of electricity to touch the tool.**
The pneumatic tool is not insulated against contact by electric sources. Because there is a risk of electric shock, do not allow sources of electricity to touch the tool.

CAUTION

- **Handle the tool with care.**
Rough handling could cause accidents or malfunctions. Do not exert an impact on the tool by throwing or dropping it.
- **Handle the Connecting Hose with care.**
Do not carry the tool by holding the Connecting Hose, and do not pull the Connecting Hose to remove it.

Safety Warnings for PNEUMATIC GRINDER

The following warnings are those required to be displayed as instructed by ISO11148-7.

General Safety Rules

WARNING

- **For multiple hazards, read and understand this instruction manual before installing, operating, repairing, maintaining, changing accessories on, or working near this tool. Failure to do so can result in serious bodily injury.**
- **Only qualified and trained operators should install, adjust or use this tool.**
- **Do not modify this tool. Modifications can reduce the effectiveness of safety measures and increase the risks to the operator.**
- **Do not discard this instruction manual; hand it to the operator.**
- **Do not use this tool if the tool has been damaged.**
- **This tool shall be inspected periodically to verify the ratings and markings. When a label/nameplate is damaged, worn or missing, contact the sales agent through which you have purchased your tool or NITTO KOHKI Co. Ltd. directly for a replacement.**

Projectile Hazards

WARNING

- Be aware that failure of the workpiece or accessories, or even of the inserted tool itself can generate high-velocity projectiles.
- Always wear impact-resistant eye protection while operating this tool. The grade of protection required should be assessed for each operation.
- Ensure that the workpiece is securely fixed.
- Ensure that the abrasive product is safely clamped to this tool.
- Check that the maximum operating speed of the abrasive product, converted to revolutions per minute, is equal to or greater than the rated speed of the spindle.
- Ensure that the guard is in place, is in good condition and is correctly mounted; ensure that the guard is regularly inspected. It is possible for internal grinding to not require a guard, provided the workpiece encloses the abrasive product.
- Check regularly that the speed of this tool is not higher than the speed marked on it. These speed checks shall be carried out without the abrasive product mounted and in accordance with the instructions given by the manufacturer.
- Check that the flanges, as specified by the manufacturer, are used and are in good condition, e.g. free from cracks and burrs, and are plane.
- Check that the spindle and spindle threads are not damaged or worn.
- Ensure that sparks and debris resulting from use do not create a hazard.
- Disconnect this tool from the energy supply before changing the abrasive product and servicing.

Entanglement Hazards

WARNING

- Choking, scalping and/or lacerations can occur if loose clothing, personal jewelry, neckwear, hair or gloves are not kept away from the tool and its accessories.

Operating Hazards

WARNING

- Avoid contact with the rotating spindle and mounted wheel to prevent cutting of hands and other body parts.
- Use of this tool can expose the operator's hands to hazards, including cuts, abrasions and burns. Wear suitable gloves to protect hands.
- Operators and maintenance personnel shall be physically able to handle the bulk, weight and power of the tool.
- Hold the tool correctly; be ready to counteract normal or sudden movements and have both hands available.
- Maintain a balanced body position and secure footing.
- Release the start-and-stop device if the energy supply is interrupted.
- Use only lubricants recommended by the manufacturer.
- Personal protective safety glasses shall be used; suitable gloves and protective clothing are recommended.
- For overhead work, wear a safety helmet.
- When cutting off the workpiece, it shall be supported such that the slot is kept at constant or increasing width during the complete operation.
- If the abrasive product becomes jammed in a cut slot, shut off the grinder and ease the wheel free. Check that the wheel is still correctly secured and not damaged before continuing the operation.
- Grinding wheels and cutting-off wheels shall not be used for side grinding. (Exception: grinding wheels designed for side grinding.) Grinders shall not be used over the maximum peripheral speed of an abrasive product.
- The operator shall pay attention and ensure that no bystanders are in the vicinity.
- Personal protective equipment, such as suitable gloves, an apron and a helmet, shall be used.
- Grinding sparks can ignite clothing and cause severe burns. Ensure sparks do not land on clothing. Wear fire-retardant clothing and have a bucket of water nearby.

Repetitive Motion Hazards

WARNING

- When using this tool to perform work-related activities, the operator may experience discomfort in the hands, arms, shoulders, neck or other parts of the body.
- While using this tool, the operator should work in a comfortable posture while maintaining secure footing and avoiding awkward or off-balance postures. The operator should change posture during extended tasks; this can help avoid discomfort and fatigue.
- If the operator experiences symptoms such as persistent or recurring discomfort, pain, throbbing, aching, tingling, numbness, burning sensations or stiffness, these warning signs should not be ignored. The operator should tell their employer and consult a qualified health professional.

Accessory Hazards

WARNING

- Disconnect the tool from the energy supply before fitting or changing the inserted tools or accessories.
- Use only accessories and consumables that are the sizes and types recommended by the manufacturer of this tool; do not use accessories or consumables of other types or sizes.
- Ensure that the dimensions of the abrasive product are compatible with this tool and that the abrasive product fits the spindle.
- Ensure that the thread type and size of the abrasive product exactly match the thread type and size of the spindle.
- Inspect the abrasive product before use. Do not use abrasive products which could (possibly) have been dropped or which are chipped, cracked or otherwise defective.
- Ensure that the abrasive product is correctly mounted and tightened before use and run this tool at no-load speed for at least 1 minute in a safe position; stop immediately if considerable vibration or other defects are detected and determine the cause of these defects.
- Prevent the spindle end from touching the bottom of the hole of cups, cones or plugs with threaded holes intended to be mounted on machine spindles, by checking their dimensions and other relevant data.
- Where abrasive products are supplied or used with reducing adaptors or bushings, the user shall ensure that the adaptor or bushing does not contact the face of the flange and that the clamping force provides sufficient rotational driving action to prevent the abrasive product from slipping.
- In cases where flanges are supplied for several types or sizes of abrasive, always fit the correct flanges for the abrasive being used.
- Avoid direct contact with the inserted tool during and after use, as it can be hot or sharp.
- Store and handle the abrasive product with care in accordance with the manufacturer's instructions.

Workplace Hazards

WARNING

- Slips, trips and falls are major causes of workplace injury. Be aware of slippery surfaces caused by the use of the tool and also of trip hazards caused by the air line or hydraulic hose.
- Proceed with care in unfamiliar surroundings. There can be hidden hazards, such as electricity or other utility lines.
- This tool is not intended for use in potentially explosive atmospheres and is not insulated against contact with electric power.
- Ensure that there are no electrical cables, gas pipes, etc., which can cause a hazard if damaged by the use of the tool.

Dust and Fume Hazards

WARNING

- Dust and fumes generated when using this tool can cause ill health (for example cancer, birth defects, asthma and/or dermatitis); risk assessment and implementation of appropriate controls for these hazards are essential.
- Risk assessment should include risks such as the dust created by the use of the tool and the potential for disturbing existing dust.
- Operate and maintain this tool as recommended in these instructions to minimize dust or fume emissions.
- Direct the exhaust so as to minimize disturbance of dust in a dust-filled environment.
- Where dust or fumes are created, the priority shall be to control them at the point of emission.
- All integral features or accessories for the collection, extraction or suppression of airborne dust or fumes should be correctly used and maintained in accordance with the manufacturer's instructions.
- Select, maintain and replace the consumable or inserted tool as recommended in the instruction handbook to prevent an unnecessary increase in dust or fumes.
- Use respiratory protection in accordance with the employer's instructions and as required by occupational health and safety regulations.
- Working with certain materials creates emissions of dust and fumes, causing a potentially explosive environment.

Noise Hazards

WARNING

- Exposure to high noise levels can cause permanent, disabling hearing loss and other problems, such as tinnitus (ringing, buzzing, whistling or humming in the ears). Therefore, risk assessment and implementation of appropriate controls for these hazards are essential.
- Appropriate controls to reduce the risk can include actions such as damping materials to prevent workpieces from “ringing”.
- Use hearing protection in accordance with the employer's instructions and as required by occupational health and safety regulations.
- Operate and maintain this tool as recommended in the instruction handbook to prevent an unnecessary increase in the noise level.
- If this tool has a silencer, always ensure it is in place and in good working order when the tool is being operated.
- Select, maintain and replace the consumable or inserted tool as recommended in the instruction handbook to prevent an unnecessary increase in noise.
- The noise-emission value in this manual is measured in accordance with ISO standards. Since the real value may change depending on the work condition, please use this tool with measurements in the actual condition. Please don't operate beyond the time set by the region where the tool is used.

Vibration Hazards

WARNING

- Exposure to vibration can cause disabling damage to the nerves and blood supply of the hands and arms.
- Wear warm clothing when working in cold conditions and keep your hands warm and dry.
- If you experience numbness, tingling, pain or whitening of the skin in your fingers or hands, stop using this tool, tell your employer and consult a physician.
- Operate and maintain this tool as recommended in the instruction handbook to prevent an unnecessary increase in vibration levels.
- Do not allow the inserted tool to chatter on the workpiece as this is likely to cause a substantial increase in vibration.
- An improperly mounted or damaged inserted tool can cause excessive vibration levels.
- Select, maintain and replace the consumable or inserted tool as recommended in the instructions handbook to prevent an unnecessary increase in vibration levels.
- Support the mass of the tool in a stand, tensioner or balancer, if possible.
- Hold the tool with a light but safe grip, taking account of the required hand reaction forces, because the risk from vibration is generally greater when the grip force is higher.
- Use blotters when using the bonded abrasive product.
- The vibration-emission value in this manual is measured in accordance with ISO standards. Since the real value may change depending on the work condition, please use this tool with measurements in the actual condition. Please don't operate beyond the time set by the region where the tool is used.

Additional Safety Instructions

WARNING

- **Air under pressure can cause severe injury:**
 - always shut off air supply, drain hose of air pressure and disconnect tool from air supply when not in use, before changing accessories or when making repairs;
 - never direct air at yourself or anyone else.
- Whipping hoses can cause severe injury. Always check for damaged or loose hoses and fittings.
- Whenever universal twist couplings (claw couplings) are used, lock pins shall be installed and whip check safety cables shall be used to safeguard against possible hose-to-tool or hose-to-hose connection failure.
- Do not exceed the maximum air pressure stated on the tool.
- Never carry an air tool by the hose.
- When a tool is taken permanently out of service, it is advised that the tool be disassembled and degreased, and parts be separated by material and recycled locally in the appropriate manner.

Product Specific Safety Rules

WARNING

- **Protect your body from chips.**

During grinding, hot chips scatter. Since it could cause blindness, respiratory disorders, burns or hearing impairment, when working, to protect your body use protective eyewear, a dust mask, earplugs, gloves (excluding knitted gloves), long-sleeved work clothes, etc. In addition, do not bring your face close to the tool.

- **Do not use a Grinding Wheel with an allowable rotational speed (indicated on the Grinding Wheel top label) lower than the actual rotational speed of the machine. Also, please make sure that the specified dimensions of the Grinding Wheel conform to the specifications of this machine.**

- **When attaching the Grinding Wheel, check that there are no abnormalities such as cracking, chipping, or excessive wear.**

Do not use the tool if there is a slight abnormality such as a Grinding Wheel containing moisture, damage, loss, etc. of the display label.

- **Use our genuine Outer Flange.**

Do not use Outer Flanges that are damaged, bent or severely worn out.
Also, do not use a substitute flange or flat washer.

- **Check that the Grinding Wheel is suitable for the Outer Flange.**

Tighten the Grinding Wheel moderately.

When aligning the Grinding Wheel to the Outer Flange do not use a reduced bushing unless the bushing to be used is supplied from the parts maker or is as specified.

- **When attaching the Grinding Wheel, make sure that the label on the top of the Grinding Wheel comes into contact with the mounting surface of the Spindle.**

For the label on top of the Grinding Wheel, use one with the same diameter as the outer diameter of the end face of the Spindle, or larger.

⚠ WARNING

- **Always inspect the Spindle's threaded part and Outer Flange for breakage, deformation and wear.**
If an abnormality is found, stop using the tool immediately.
- **Never use the side other than the usage surface of the Grinding Wheel.**
- **Be sure to install a Wheel Guard on the air grinder having a tip Grinding Wheel tool maximum diameter of 50 mm or more.**
- **Be sure to use the Wheel Guard provided with this machine.**
Use of equipment other than as specified could cause an accident.
- **Always replace damaged, deformed, or excessively worn Wheel Guards.**
Do not use a Wheel Guard that could cause damage to the Grinding Wheel.
- **The intake air pressure during operation of this tool should not exceed 0.6 MPa.**
- **Do not abruptly operate or stop the tool.**
When starting, be sure to open the Throttle Lever or Valve Ring gradually.
- **When performing any work, before attaching the Grinding Wheel be sure to use a tachometer to check the no-load rotation speed of the tool.**
Make sure the Valve Ring of the main unit is at the maximum rotation position and that the rotation speed at 0.6 MPa does not exceed the rotation speed stated on the Wheel Guard.
Also, when you use this unit after repair, check in the same way.
- **During trial operation, make sure that there is no one near the rotating Grinding Wheel.**
- **At startup, push the Grinding Wheel slowly against the workpiece until the Grinding Wheel gets warm.**
- **Always work at the correct angle of 15 to 30 degrees.**

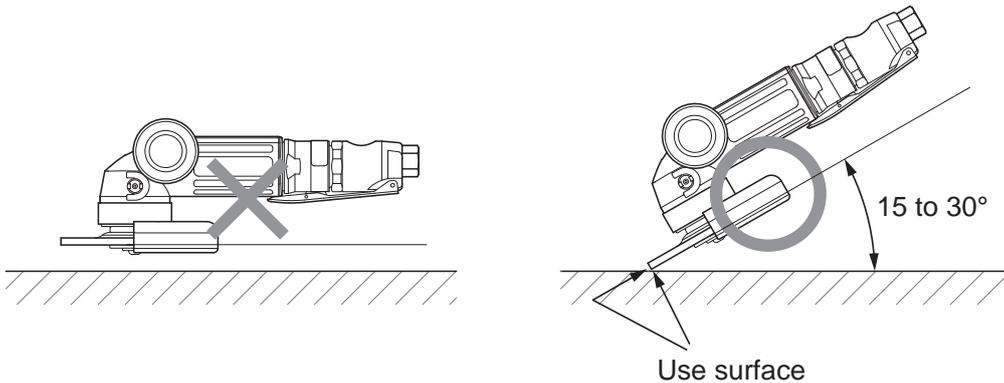

1 Application

This tool is a pneumatic hand-held grinder for grinding a workpiece using the Grinding Wheel shown below according to the shape of the Type 27 Depressed Center Grinding Wheel.

MYG-50

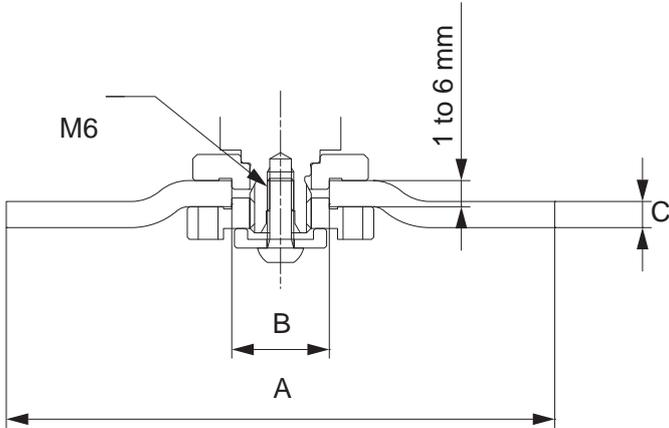

	MYG-50
A Depressed Center Grinding Wheel diameter	125 mm (5")
B Depressed Center Grinding Wheel hole diameter	22.2 mm (7/8")
C Depressed Center Grinding Wheel thickness	1 to 6 mm (3/64 to 1/4")

2 Checking Inside the Package

When you open the package box, check the contents of the package and also check for any damage that may have occurred during transportation.

If an abnormality is found, request service from the retailer where you purchased the tool or the nearest NITTO service member store.

	Package content and accessories	Quantity	Check
①	MYG-50 (main unit)	1	
②	Wheel Guard Ass'y	1	
③	Side Handle Ass'y	1	
④	4 mm Hex. Socket Screw Key	1	
⑤	6 mm Hex. Socket Screw Key	1	

	Package content and accessories	Quantity	Check
⑥	Pin Face Wrench	1	
⑦	Instruction Manual (this document)	1	
⑧	Caution for Use	1	
⑨	Bushing R 3/8 x NPT 3/8	1	
⑩	EC Declaration of Conformity	1	

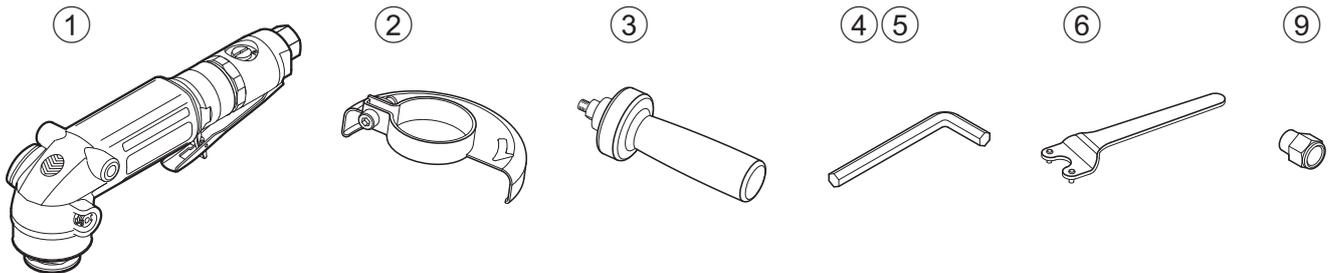

3 Part Names

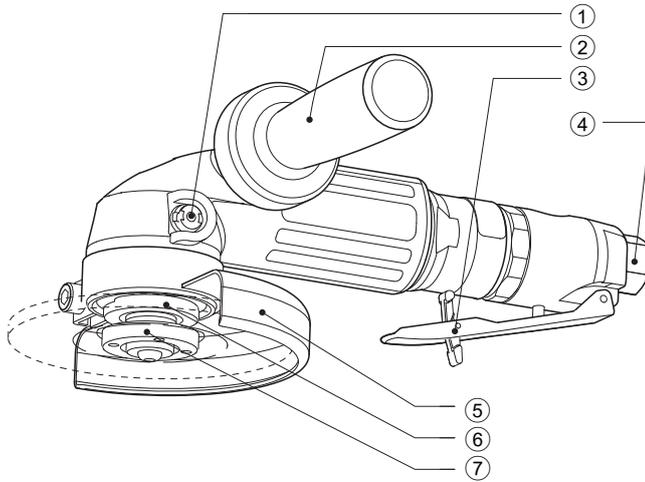

- ① Spindle Lock Button
- ② Side Handle Ass'y
- ③ Throttle Lever
- ④ Bushing
- ⑤ Wheel Guard
- ⑥ Driving Flange
- ⑦ Outer Flange

4 Air Supply

⚠ CAUTION

- Remove drainage before stating work.

When drainage enters the tool, the vicinity of the exhaust port freezes, which could cause a loss of power.

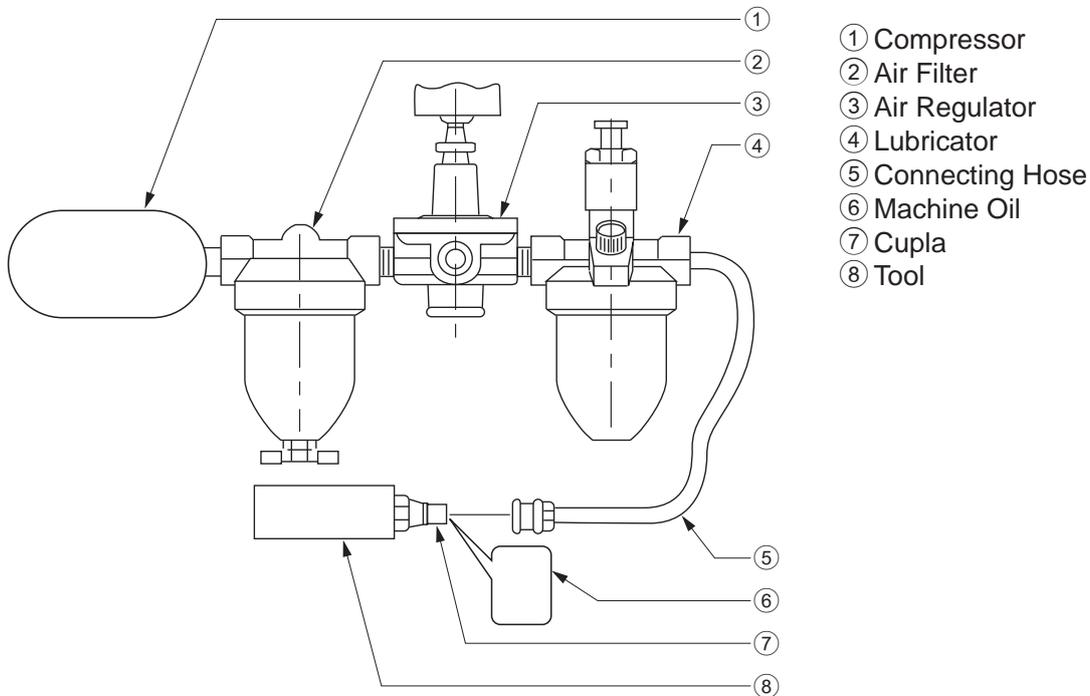

Air pressure used

Use the tool with air pressure at 0.6 MPa. If the pressure is too low, the tool cannot demonstrate the required performance. If it is too high, it could damage parts of the tool. Use an Air Regulator (③) to adjust the pressure to the appropriate level.

Air line

Use a Connecting Hose (⑤) with an internal diameter of 9.5 mm (3/8") between the Compressor (①) and the tool (⑧). Compressed air exits the Compressor and cools and moisture condenses. Some moisture could condense inside the Connecting Hose and get inside the tool, causing a malfunction. Install the Air Filter (②) and Lubricator (④) between the Compressor and the tool.

Machine oil

Install a Lubricator between the Compressor and the tool, and be sure to use machine oil (ISO VG-10).

Failure to do so could cause damage to the tool. Also, if lubricating oil with high viscosity is used, it could cause performance degradation.

Refueling

Each day before starting work detach the Connecting Hose and refill a few drops of machine oil (ISO VG-10) (⑥) from the Cupla (⑦) to the tool.

After refueling, connect the Connecting Hose and perform idle operation for a few seconds to allow the oil to blend in the entire tool.

5 Preparation

⚠ WARNING

- During work, be sure to wear eye protection, earplugs, a dust mask, and gloves (other than knitted gloves).
- When replacing or adjusting the Grinding Wheel or parts, be sure to detach the Connecting Hose from the tool.
- Never touch moving parts while the tool is running.
- After stopping work, the tip of the grinding tool will continue to rotate for a while.
Never touch moving parts until the tool completely stops.

Attaching the Wheel Guard Ass'y

⚠ WARNING

- Before replacing the Wheel Guard Ass'y, always turn OFF the Throttle Lever and detach the Connecting Hose from the tool.

1 Fit the Wheel Guard Ass'y (①) into the groove of the main unit (③)

2 Use the 6 mm Hex Socket Screw Key (④) to tighten the bolt (②) to secure the Wheel Guard Ass'y

Make sure to use the product after attaching the Wheel Guard Ass'y.

- ① Wheel Guard Ass'y
- ② Bolt
- ③ Groove on main unit
- ④ 6 mm Hex. Socket Screw Key

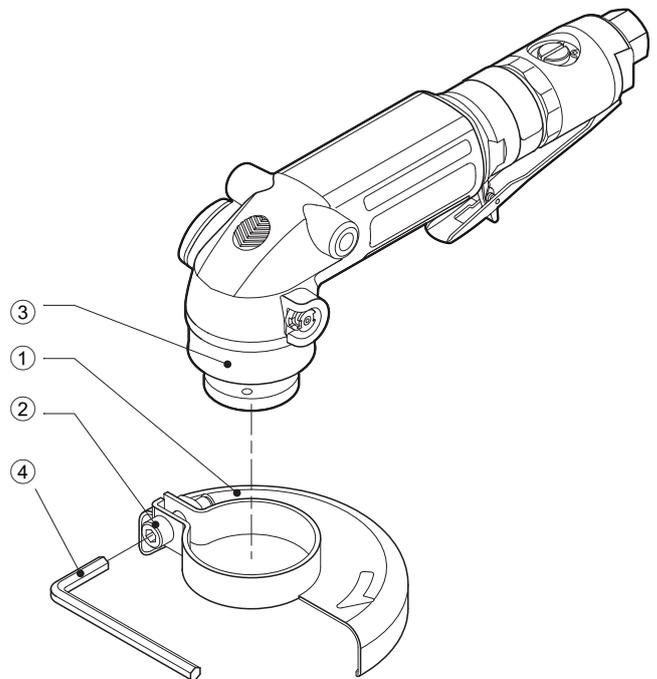

Attaching the Side Handle Ass'y

⚠ WARNING

- Before replacing the Side Handle Ass'y, always turn OFF the Throttle Lever and detach the Connecting Hose from the tool.

- 1 Screw into the Boss (2) at the front part of the main unit**
The Side Handle Ass'y (1) can be attached to either the left or right side.
Make sure to use the product after mounting the Side Handle Ass'y.

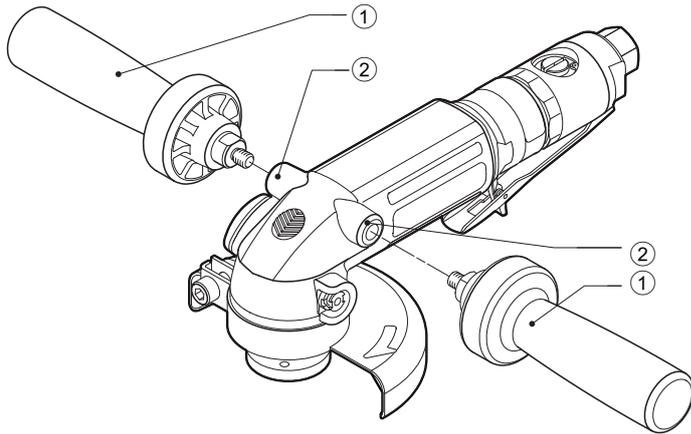

- ① Side Handle Ass'y
- ② Boss

Replacing the Grinding Wheel

⚠ WARNING

- Before replacing the Grinding Wheel, always turn OFF the Throttle Lever and detach the Connecting Hose from the tool.

Attaching

- 1 Hold the Spindle (2) with pushing the Spindle Lock Button (1)
- 2 Insert the Driving Flange (3) into the Spindle (2) to fit the convex on the Spindle (2) and groove of Driving Flange (3)
- 3 Insert the Grinding Wheel (4) and Outer Flange (5) into the Spindle (2)
- 4 In case the Grinding Wheel (4) is 4 mm or less, attach the Outer Flange (5) up side down
- 5 Secure it firmly to the Spindle (2) by tightening the Outer Flange (5) with Pin Face Wrench (6)
- 6 Secure Washer (7) and Hex. Socket Button Head Screw 6x15 (8) firmly to the Spindle (2) by tightening the Hex. Socket Button Head Screw 6x15 (8) with Hex. Socket Screw Key (9)

Removing

- 1 Hold the Spindle (2) with pushing the Spindle Lock Button (1)
- 2 Loosen the Hex. Socket Button Head Screw 6x15 with Hex. Socket Screw Key (9) and remove the Washer (7)
- 3 Loosen the Outer Flange (5) with the Pin Face Wrench (6)
This makes it possible to remove the Grinding Wheel.
- 4 Remove the Grinding Wheel

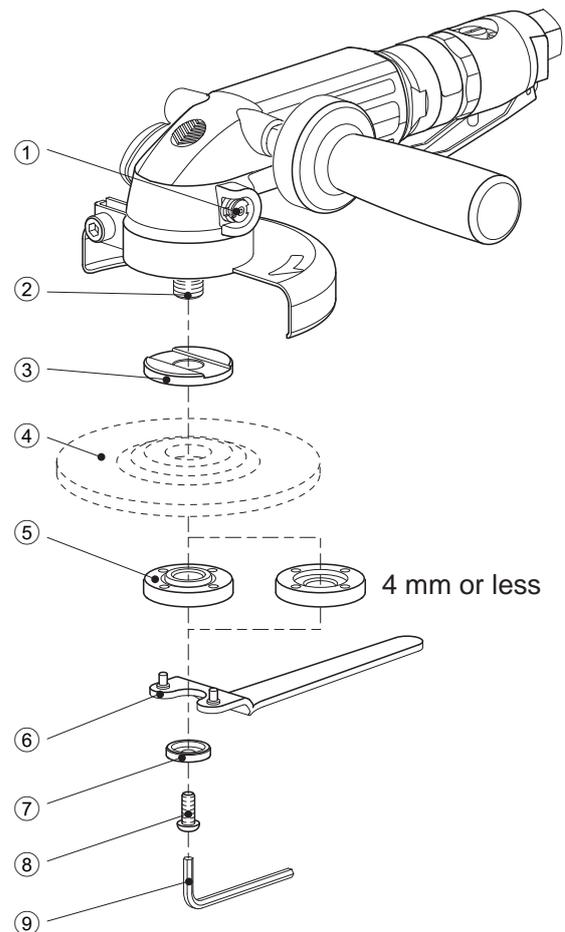

- ① Spindle Lock Button
- ② Spindle
- ③ Driving Flange
- ④ Grinding Wheel
- ⑤ Outer Flange
- ⑥ Pin Face Wrench
- ⑦ Washer
- ⑧ Hex. Socket Button Head Screw 6x15
- ⑨ 4 mm Hex. Socket Screw Key

Start and stop

Start

- 1 Check that the Throttle Lever is in the OFF status and insert the Connection Hose into the Cupla of this tool

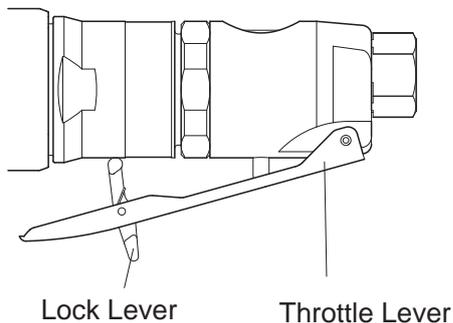

- 2 Hold the tool and while pressing the Lock Lever (①), press the Throttle Lever (②)
The tool starts.

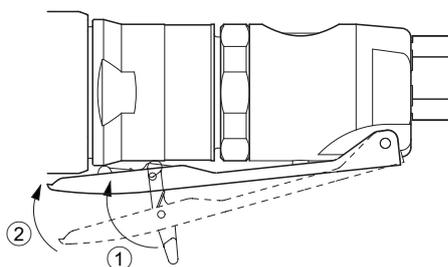

Stop

- 1 Release your hand from the Throttle Lever
The Throttle Lever automatically returns to the OFF status.

Adjusting the rotation speed

⚠ WARNING

- Never touch the tip of moving parts.

- 1 Use a flathead screwdriver to turn the Adjust Valve
The air flow rate changed that allows the rotation speed to be adjusted.
The maximum rotational position is when the screwdriver groove of the valve coincides with the axis center of the main unit. Adjust the position according to the purpose of use.

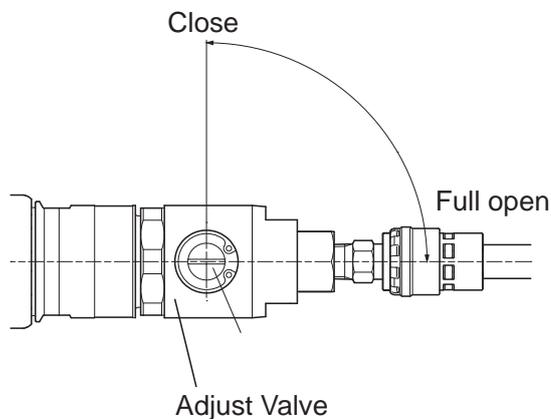

6 How to Use

Grinding work

⚠ CAUTION

- **Do not press the Grinding Wheel strongly against the working surface.**
Doing so could damage parts or damage the Grinding Wheel. Strongly pressing the tool against the working surface does not change work efficiency.

- 1 Hold the tool with your hand to start
- 2 Lightly touch the Grinding Wheel at an angle of 15 to 30 degrees against the working surface

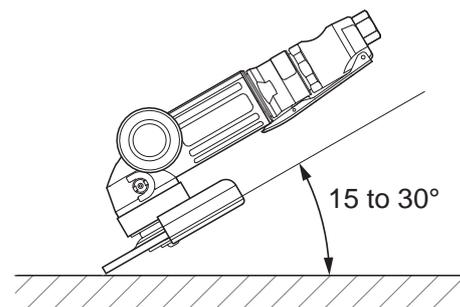

7 Maintenance and Inspection

Storing the tool

Store the tool according to the following warnings and cautions.

WARNING

- When the tool is not in use, store out of the reach of children.

CAUTION

- When the tool is not in use, store in a place with little humidity.
- After completing work, lubricate with machine oil (ISO VG-10) from the Cupla of the tool and operate a little before storing.
If the tool is left as is after use, moisture in the air could remain inside the main unit, likely causing rust to occur.

Storing the Grinding Wheel

Store the Grinding Wheel according to the following warnings.

WARNING

- Avoid moisture, and store the Grinding Wheel in a dry place. When storing or handling, observe the following items.
 - Do not expose to moisture
 - Do not drop
 - Do not expose to impacts
 - Do not throw
 - Do not step on
 - Do not roll

Maintenance and Inspection

WARNING

- For maintenance and inspection, be sure to detach the connecting hose from the tool.
- Use genuine parts.
- Never touch moving parts while the tool is running.

Replenishing grease

Apply grease (Sumitec 305) as needed to the inside of the main unit about once a month according to the following procedure.

At that time, use an air blower or the like to remove dirt adhering to the Exhaust Filter. Also, depending on dirt conditions, replace the Exhaust Filter as needed. If dirt adheres to the Exhaust Filter, it could cause a loss of power.

- 1 Loosen the + Countersunk Head Screw (①) of the Exhaust Cover and remove the Exhaust Cover (②), Spacer (③), Exhaust Filter (the ④1st Filter), Exhaust Plate (⑤), and Packing Cover (⑥)**

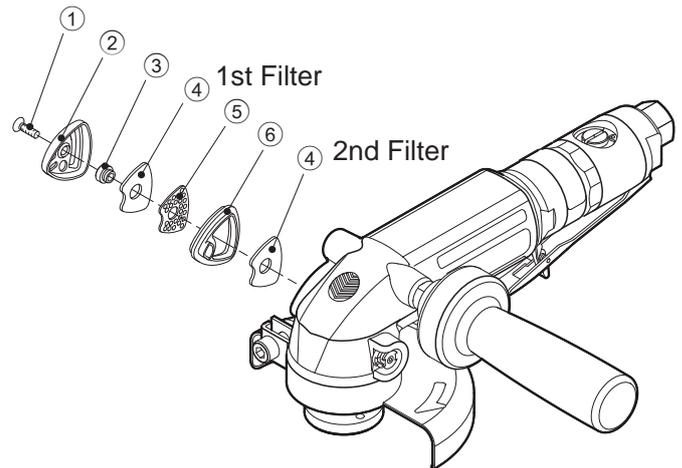

- ① + Countersunk Head Screw 4x14
- ② Exhaust Cover
- ③ Spacer
- ④ Exhaust Filter
- ⑤ Exhaust Plate
- ⑥ Packing Cover
- ⑦ Grease Inlet

- 2 Use a grease gun to inject grease (Sumitec 305) into the Grease Inlet (⑦)**

Use a grease gun nozzle with a tip outer diameter of less than 3 mm.

The nozzle for a grease nipple cannot be used for injection.

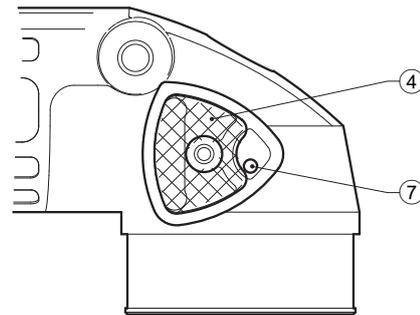

- 3 Perform a trial run and wipe off extra grease that seeps out**

Attach a Connecting Hose to the Cupla of the tool and operate the tool.

At that time, grease may scatter from the exhaust part and Grease Inlet, so use with care.

Stop the tool in a few seconds and always detach the tool from the Connecting Hose, then wipe off any grease that seeps from the periphery of the Spindle.

- 4 Assembling the Exhaust Cover**

Assemble the Exhaust Cover by performing the disassembly procedure in reverse.

MYG-50 uses two Exhaust Filters (④). Insert the Exhaust Filter (the ④2nd Filter) under the Packing Cover so that there is no clearance in the housing.

When assembling, use care for the orientation of the Exhaust Cover (②), Exhaust Filters (④), Exhaust Plate (⑤), and Packing Cover (⑥).

Disposal

- Separate the tool, accessories, and packing materials for environmentally-friendly recycling.
- When disposing of the tool, follow the rules of each municipality.

8 Exploded View/Parts List

MYG-50 Exploded View/Parts List

⚠ CAUTION

- Users should never perform disassembly of the tool.

This illustration is for reference only.

For repair or replacement of the tool, request service from the retailer where you purchased the tool or the nearest NITTO service member store.

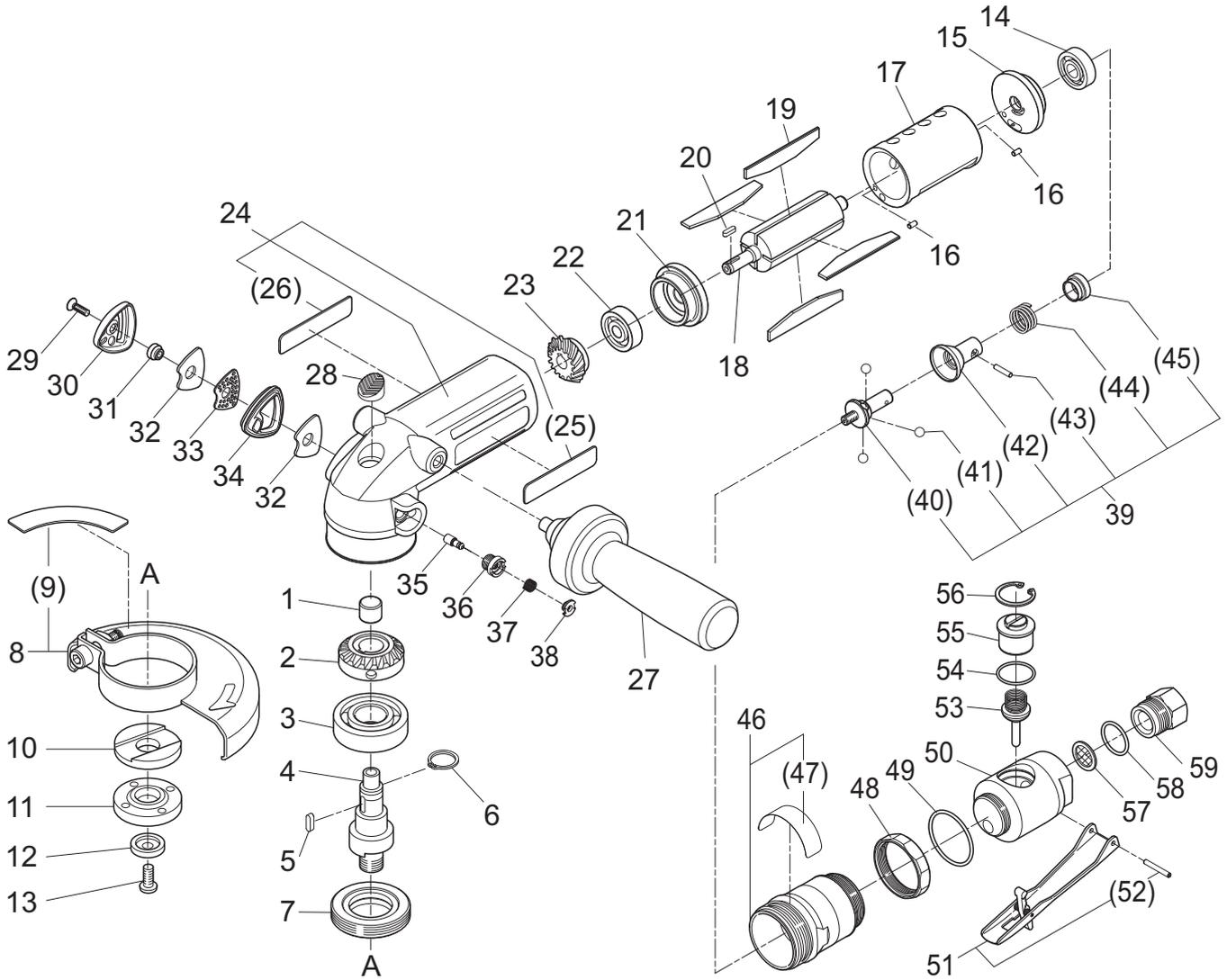

*1 indicates a consumable item, *2 indicates a commercial item. Parts inside () are components of the above assembly.

No.	Part no.	Part name	Quantity
*1 *2	1	TQ12088 Needle Bearing BK1012	1
*1	2	TQ14290 Gear	1
*1 *2	3	TP04138 Ball Bearing 6204ZZ	1
	4	TQ14289 Spindle	1
	5	TP09933 Parallel key Both Ends Round 4x4x12	1
	6	TP18356 External Retaining Ring C-14	1
	7	TB08263 Bearing Set Screw Ass'y	1 set
	10	TQ04123 Driving Flange	1
	11	TQ04124 Outer Flange	1
	12	TQ04139 Washer	1
	13	TP14688 Hex. Socket button head Screw 6x15	1

No.	Part no.	Part name	Quantity	
*1 *2	14	TP06242	Ball Bearing 629ZZ	1
	15	TQ12063	End Plate A	1
	16	TP04061	Spring Pin 3x6 AW	2
	17	TQ12062	Cylinder	1
	18	TQ14928	Rotor	1
*1	19	TB08555	Blade Ass'y (4pcs.)	1 set
	20	TP10130	Parallel key Both Ends Round 3x3x10	1
	21	TQ12064	End Plate B	1
*1 *2	22	TQ12087	Ball Bearing 638ZZ	1
*1	23	TQ14288	Pinion	1
	24	TB10179	Housing Sub Ass'y	1 set
	(25)	(TQ15043)	Label Model	1
	(26)	(TQ15216)	Label Warning	1
	28	TQ14980	Plug 70	1
	29	TQ14946	+ Countersunk Head Screw 4x14	1
	30	TQ15090	Exhaust Cover 70	1
	31	TQ15140	Spacer	1
*1	32	TQ15143	Exhaust Filter 70	2
	33	TQ15142	Exhaust Plate 70	1
	34	TQ15141	Packing Cover	1
	35	TQ14863	Lock Pin	1
	36	TQ14865	Pin Guide	1
	37	TQ14864	Spring 0.6x6.9x8	1
	38	TQ14866	Lock Button	1
	39	TB10092	Governor Ass'y	1 set
	(40)	(TQ12813)	Base	1
	(41)	(TP01566)	Steel Ball Ø6	3
	(42)	(TQ12067)	Sleeve	1
	(43)	(TQ12090)	Needle Roller 2.5x13.8	1
	(44)	(TQ12069)	Spring 1.4x15.5x14.2	1
	(45)	(TQ12068)	Stopper	1
	46	TB10526	Valve Holder Ass'y	1 set
	(47)	(TQ15044)	Label Specification	1
	48	TP17452	Lock Ring	1
	49	TP17445	O-ring S-35.5	1
	50	TQ12662	Valve Body	1
	51	TB08669	Lever Ass'y	1 set
	(52)	(TP13893)	Spring Pin 3x22 AW	1
	53	TB09001	Valve Stem Ass'y	1 set
	54	TP10714	O-ring S-22	1
	55	TQ12668	Adjust Valve	1
	56	TP10448	Internal Retaining Ring C-24	1
	57	TP01658	Filter	1
	58	CP25821	O-ring JASO-1020	1
	59	TQ12671	Bushing M23xRc 3/8	1

Accessories

No.	Part no.	Part name	Quantity
8	TB10400	Wheel Guard Ass'y	1 set
(9)	(TQ15046)	Label Warning for Wheel Guard	1
27	TB09680	Side Handle Ass'y (M8)	1
	TQ02350	Bushing R 3/8xNPT 3/8	1
	TP01939	4 mm Hex. Socket Screw Key	1
	TP00170	6 mm Hex. Socket Screw Key	1
	TQ04125	Pin Face Wrench	1
	TQ15279	Instruction Manual	1



■ Overseas Affiliates / Offices

NITTO KOHKI U.S.A., INC.

46 Chancellor Drive, Roselle, IL 60172, U.S.A.
Tel: +1-630-924-9393 Fax: +1-630-924-0303

NITTO KOHKI EUROPE GMBH

Gottlieb-Daimler-Str. 10, 71144 Steinenbronn, Germany
Tel: +49-7157-989555-0 Fax: +49-7157-989555-40

NITTO KOHKI EUROPE GMBH UK BRANCH

Unit A5, Langham Park Industrial Estate, Maple Road, Castle
Donington, Derbyshire DE74 2UT, U.K.
Tel: +44-1332-653800 Fax: +44-1332-987273

NITTO KOHKI AUSTRALIA PTY.LTD.

77 Brandl Street, Eight Mile Plains, Queensland 4113, Australia
Tel: +61-7-3340-4600 Fax: +61-7-3340-4640

NITTO KOHKI (SHANGHAI) CO., LTD.

Room1506, Suite C, Orient International Plaza, No.85
Loushanguan Road, Shanghai 200336, China
Tel: +86-21-6415-3935 Fax: +86-21-6472-6957

NITTO KOHKI (SHANGHAI) CO.,LTD. Shenzhen Branch

2005C Shenzhen ICC Tower, Fuhuasanlu 168, Futian District,
Shenzhen, Guangdong 518048, China
Tel: +86-755-8375-2185 Fax: +86-755-8375-2187

NITTO KOHKI CO., LTD., Singapore Branch

10 Ubi Crescent #01-62, Ubi Techpark Lobby D, Singapore
408564
Tel: +65-6227-5360 Fax: +65-6227-0192

NITTO KOHKI CO., LTD., Bangkok Representative Office

M&A Business Center, Q-House Convent Bldg., 38 Convent
Rd., Silom, Bangrak, Bangkok 10500, Thailand
Tel: +66-2632-0307 Fax: +66-2632-0308

NITTO KOHKI CO.,LTD. India Liaison Office

3rd Floor, Building No.9-A DLF Cyber City, Phase-III,
Gurgaon, Haryana 122002, India
Tel: +91-124-454-5031 Fax: +65-6227-0192

NITTO KOHKI CO.,LTD. Mexico Representative Office

OF1109 Torre Corporativo 1 Piso 11 Central Park Armando
Birlain Shaffler #2001 Col Centro Sur, Queretaro, Qro,
C.P.76090, Mexico
Tel: +52-442-290-1234