

# ***INSTRUCTION MANUAL***

## **PNEUMATIC FILE**

Please read this manual carefully before you attempt to use your tool so that you may use it properly and safely.

## **SUPER HAND LIGHT Model SHL-40 PROFESSIONAL TOOL**



### **Specifications**

<b>Model</b>	<b>SHL-40</b>	
Max Operating Pressure	MPa	0.6
Air Consumption (No Load)	m <sup>3</sup> /min	0.07
Stroke Speed (No Load)	min <sup>-1</sup>	9000
Stroke Length	mm	4
Shank O.D.	mm	3
Mass (Weight)	Kg	0.4
Sound Pressure Level	dB(A)	75
Sound Power Level	dB(A)	72
Vibration Level	m/s <sup>2</sup>	≤2.5
Air Inlet Size		Rc 1/4

Due to continuous product development/improvement the specifications and configurations in this document are subject to change without prior notice.



Manufactured by :

**NITTO KOHKI Co., Ltd.**

2-9-4, Nakaikegami, Ohta-ku,  
Tokyo, 146-8555, Japan

Tel : (81)-3-3755-1111

Fax : (81)-3-3753-8791

E-mail : [overseas@nitto-kohki.co.jp](mailto:overseas@nitto-kohki.co.jp)

URL : [www.nitto-kohki.co.jp](http://www.nitto-kohki.co.jp)

**Keep the manual handy – so you can use it whenever necessary.**

Original Instructions

Thank you very much for your purchase of this **Nitto Kohki products**.

Before using your tool, please read this manual carefully so that you may use it properly to get the most out of it.

**Please keep the manual handy - so you can use it whenever necessary.**

- **English** : Please ask your dealer or distributor for instruction manual in local language(s).
- **German** : Bitte fragen Sie Ihren Händler nach eine Betriebsanleitung in Landessprache.
- **French** : S'il vous plait, veuillez demandez á votre fournisseur de manuel instruction en langue locale.
- **Spanish** : Por favor, contacte con su distribuidor para el manual de instrucciones en español.
- **Portuguese** : Por favor pessa ao seu agente ou distribuidor o manual de instruções em linguagem local.
- **Italian** : Per Manuale Istruzioni in lingua locale Vi preghiamo di rivolgerci al rivenditore o distributore.
- **Dutch** : Vraag uw handelaar om een nederladstalige gebruiksaanwijzing.
- **Swedish** : Be er lokala Åtreförsäljare eller distributör om manualer på svenska.
- **Danish** : Venligst henvend Dem til den danske distributør for instructions manualer.
- **Polish** : Proszę pytać swojego dealera lub dystrybutora o instrukcje obsługi w języku localnym.
- **中文** : 請向當地供應商或經銷商詢問中文使用說明書

<b>CONTENTS</b>	<b>page</b>
IMPORTANT SAFETY INSTRUCTIONS .....	2
GENERAL: TOOLS .....	2
GENERAL: PNEUMATIC TOOLS .....	3
INSTRUCTIONS FOR THIS TOOL .....	4
1. USAGE .....	4
2. CHECK THE CONTENTS OF THE PACKAGE .....	4
3. NAME OF PARTS .....	4
4. AIR SUPPLY .....	5
5. OPERATION .....	5
6. STORING TOOL .....	6
7. ORDERING SERVICE PARTS .....	6
8. OPTIONAL PARTS .....	6
9. EXPLODED DIAGRAM : SHL-40 .....	7

### PICTOGRAM



Warning: It might be dangerous to operate the tool if the instructions supplied are not followed.



Using this tool improperly could result in serious injury. Read the instruction manual before using.



Always wear suitable eye protection.



Always wear suitable hearing protection.



Always wear respiratory protective equipment.



Always wear protective gloves for protection of hands from Vibration and Shock

The following Safety notations are used throughout the manual to highlight safety precautions for the user and for the tool.



#### **WARNING:**

Indicates a potentially hazardous situation which, if not avoided by following the instructions given, could result in death or serious injury.



#### **CAUTION:**

Indicates a potentially hazardous situation which, if not avoided by following the instructions given, could result in injury or material damage.

Please note, however, that failure to observe safety precautions under the “**Caution**” category could result in a serious occurrence depending on the situation: please observe all safety precautions in the manual.

**Caution:** Important precautions for tool setup, operation and maintenance.

# IMPORTANT SAFETY INSTRUCTIONS

When using the tool, please observe the safety precautions below to prevent possible accident or injury.

## GENERAL: TOOLS

### WARNING

#### TO OPERATORS

- **Wear proper clothing for the type of work being done.**  
Take care so that clothing, ties, hair, etc. will not become entangled with the moving parts. If items become entangled it will cause the operator to be pulled towards the tool and lead to possible cause of accident or injury.
- **Always wear suitable eye protection.**  
Vision correction glasses are not safety glasses. Always wear appropriate safety glasses when doing your job.
- **Always wear suitable hearing protection.**
- **Wear respiratory protective equipment (PPE).**  
Wear respiratory protective equipment (PPE) when working in an environment where dust particles are generated in operation.
- **Avoid working posture that is too stressful.**  
Always ensure a firm footing and well balanced posture.
- **Do not operate the tool if you are too tired.**
- **Never touch any moving parts of the tool when running.**

#### ABOUT WORK AREA

- **Keep the work area clean.**  
Cluttered work areas (e.g. workbench) invite accidents.
- **Carefully select the work area.**  
Do not expose tool to rain.  
Do not use tool in a wet or soaked area.  
See that the work area is adequately illuminated.
- **Never work near inflammable liquid or in a potentially explosive atmosphere.**
- **Keep children away from the work area.**  
Keep children and unauthorized people away from the work area to avoid accident or injury.
- **Some tools generate high noise levels.**  
Check to be sure that the use of this tool conforms to all local noise regulations.

#### BEFORE OPERATION

- **Inspect tool before use.**  
Before using, check that screws are securely tightened, that any protective cover or guard is securely in place, other parts are free from damage and that the tool runs as it should.  
Check that moving parts are properly adjusted for positioning and tightened, that parts are free from damage and properly mounted, and that all other parts are in good condition for normal operation.  
Should you find any damage to the protective cover or other part, replace it in accordance with the Instruction Manual. If there are no instructions in the Manual, please contact the sales agent through which you have purchased your tool or an authorized dealer near you for repair.  
Likewise, if a switch failure occurs, contact sales agent through which you have purchased your tool or an authorized dealer near you for repair. .  
Do not use the tool if it does not start or stop with the start/stop switch.
- **Securely mount file.**  
An improperly mounted file may fly out, causing possible damage to the tool or injury to the operator.
- **Always remove spanner, wrench, etc., once adjustment has been made with them.**
- **Use a tool appropriate for the application.**  
Avoid heavy-duty application that is beyond the capacity of tool.
- **Do not use the tool for purposes other than what it is designed for.**
- **Do not abuse tool.**  
Use tool in accordance with the specifications: you'll get the most out of it while ensuring safety.
- **Securely fasten workpiece in place.**  
Use a vice or clamp to securely fasten the workpiece in place. It is much safer this way than holding it in your hand, allowing you to operate the tool with both hands.

#### ABOUT HANDLING

- **How to store tool.**  
When the tool is not used, store it in a dry area and out of reach of children.
- **How to carry tool.**  
Do not touch the start switch while the tool is being carried.
- **Do not leave the tool unattended while it is running.**  
Turn off the start switch and disconnect the tool from power source. Do not leave the work area until the tool comes to a complete stop.

## MAINTENANCE/SERVICE

- **Do not take apart or modify tool.**

Disassembly or modification carried out without the supervision of a qualified or authorized service engineer could result in an accident or injury.

- **Inspect cutting tool and accessories, etc.**

Always check to see that cutting tool and accessories, etc. are in good operating condition without damage or deterioration before you mount them on the tool. Should you find any damage to an accessory or part, please contact sales agent through which you have purchased your tool or an authorized dealer near you for repair.

- **Check parts for damage.**

When you have found damage to accessory or other part, carefully check the damaged part to determine the extent of influence it has upon the functions of the tool – that is, determine whether it can still perform its normal functions.

Check to see that moving parts are securely mounted is OK, that all parts are OK without damage, that they are properly mounted, and that the tool functions normally. Should you find any damage to an accessory or part that may hamper proper functioning of the tool, please contact sales agent through which you have purchased your tool or an authorized dealer near you for repair.

- **Have your tool repaired at an authorized Nitto Service Center.**

For repair or parts replacement, please contact the sales agent through which you have purchased your tool or an authorized dealer near you.

- **Use only Nitto genuine parts.**

Use of improper parts may result in serious an unexpected accident.

To obtain a Nitto genuine part, consult this Manual or contact the sales agent from which you have purchased your tool directly.

- **Do not detach label or nameplate from tool.**

When a label/nameplate gets damaged, worn or becomes missing, contact the sales agent through which you have purchased your tool or Nitto Kohki Co., Ltd. directly for a replacement.

## DISPOSAL

- When a tool is taken permanently out of service, it is advised that the tool is disassembled, degreased and parts separated by material and recycled locally in the appropriate manner.

## GENERAL:PNEUMATIC TOOLS

### WARNING

- **Use appropriate air pressure.**

Excessively high air pressure will increase the number of revolutions or strokes causing not only potential premature failure/breakage but could also lead to an unexpected accident or injury.

- **Connect tool to air supply line.**

There are various types of pipes running in a factory in addition to the pneumatic line (such as oxygen, nitrogen, gas and water). For this reason, always ensure that you are connecting to the pneumatic line.

- **Start tool properly.**

Turn the start switch OFF before connecting to the air supply line.

- **Always disconnect the tool from the air supply line before putting on/taking off any accessory and prior to carrying out any maintenance work.**

- **Avoid exposure to exhaust air.**

Pneumatic tool exhaust air contains oil and contaminated moisture. Make sure the exhaust air is not directed towards your face or anyone else within the work area.

- **Keep tool off electricity.**

This pneumatic tool is not electrically insulated. To avoid a potential electric shock do not use where there is a possibility of coming into contact with live electricity.

### CAUTION

- **Handle tool carefully.**

Abusive use of tool could invite failure or accident. Do not throw, drop or shock the tool.

- **Handle connecting hose carefully.**

Do not carry the tool by the air hose. Do not pull the air hose to disconnect.

# INSTRUCTIONS FOR THIS TOOL

## About Your Tool

### WARNING

- **Wear protective glasses and a dustproof mask.**  
Operation generates chips and dust particles, etc. which may cause eye and/or respiratory injury: Always use PPE (Personal Protective Equipment) for eye and respiratory protection.

### CAUTION

- **Insert the shank of the file into the holder as deep as possible before using the tool.**  
Imperfect insertion of the file shank not only damages the main body but also causes the file to jump out and may cause accidents.
- **Do not use the file with the shank other than 3mm.**  
The use of the file with the shank other than 3mm may damage the main body, cause the file to fly out and result in accidents.
- **Use NITTO genuine parts files.**
- **Whenever you replace or adjust the file or any component, be sure to detach the tool from the air.**
- **Never touch the moving parts while in operation.**

## 1. USAGE

This tool is for filing the workpieces using the exclusive file.

## 2. CHECK THE CONTENTS OF THE PACKAGE

Check the contents and make sure that the tool does not have any damage which may have occurred during transportation. The contents should correspond to the list as follows. In case of damage/missing parts, please contact the sales agent from whom you purchased the tool.

Package Contents	Q'ty	check
SUPER HAND LIGHT SHL-40	1set	
Flat File LF-13	1	
Hex. Socket Screw Key 2	1	
Bushing R1/4 × NPT1/4	1	
Instruction Manual	1	
Attention for Start-up	1	
Caution for Use	1	
Declaration of Conformity	1	

## 3. NAME OF PARTS

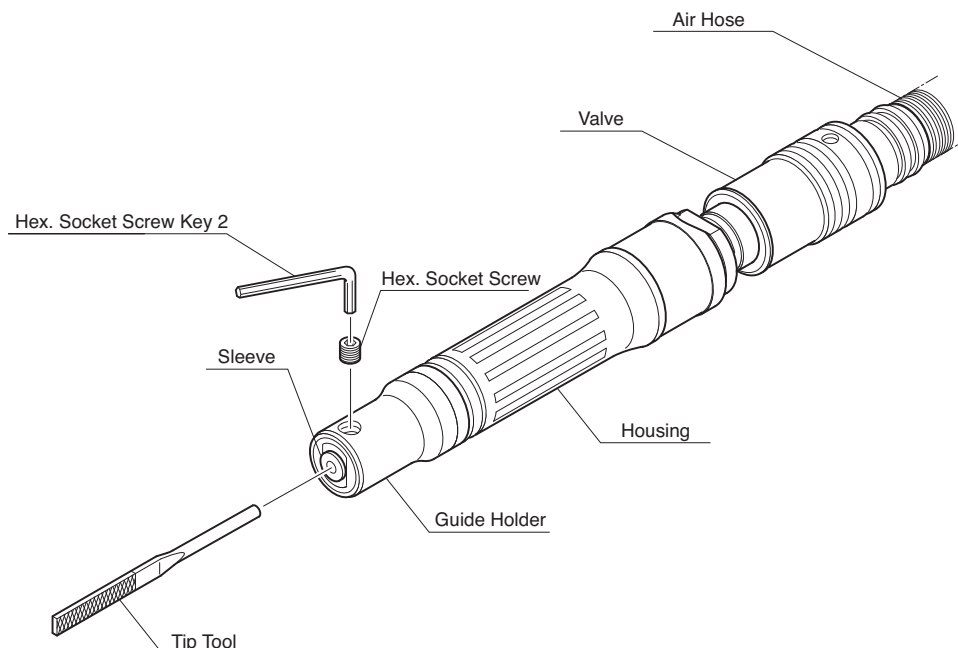

Fig.1

## 4. AIR SUPPLY

### ⚠ CAUTION

- Draw off drain before starting operation. If the drain enters into the tool, it can freeze around the exhaust port of the tool and result in output power reduction.

#### 4-1. Air Pressure

Adjust air pressure to 0.6MPa (or 6 kgf/cm<sup>2</sup>) with the air regulator. Lower pressure may result in insufficient performance. Higher pressure may result in premature worn out of parts. It is important to maintain the proper pressure with pressure regulator on air line.

#### 4-2. Air Line (Fig.1)

Use a 9.5 mm (3/8") I.D. air hose between the compressor and the tool. Compressed air comes to be cooled down and its drain be separated, as soon as the air leaves the compressor. The drain, however, is condensed in the piping, and can enter into the tool mechanism, and may cause malfunction. So, install an air filter and an oiler between the compressor and the tool.

#### 4-3. oiler

Install an oiler between the compressor and the tool. Use machine oil ISO VG-10 for lubrication and rust prevention. Negligence of the oil supply may cause damages on the tool. Lubricating the tool with high viscosity oil reduces the tool performance.

#### 4-4. Lubrication (Fig.2)

Before starting the tool, disconnect air hose from the tool and supply a few drops of machine oil ISO VG-10 to the air inlet port of the tool. Then reconnect and make idle running for a few seconds so that the oil should reach every part in the tool.

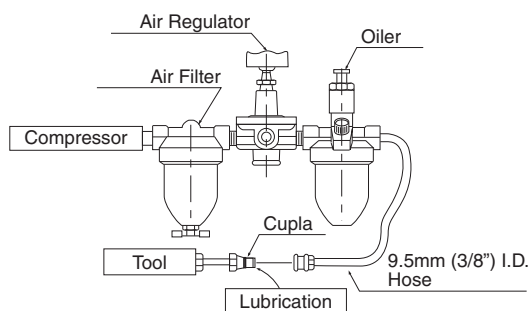

Fig. 2

## 5. OPERATION

### 5-1. How to Mount/Remove the file (Fig.3)

### ⚠ WARNING

- Move the Valve to OFF and disconnect the air hose before replacing the file.
- Inspect the file for chips or cracks prior to mounting.

Do not use the file that is chipped or cracked or otherwise damaged.

- Do not operate the tool without mounting the file. It may cause damage and loss of fixed parts.
- When removing the file, do not loosen the Hex. Socket Set Screw excessively. It may cause the sleeve to come off and lead to losing it.

#### Mounting

Insert the file shank into the sleeve and tighten a Hex. Socket Set Screw with a Hex. Socket Screw Key 2 until the file is securely fixed.

#### Removing

Loosen the Hex. Socket Set Screw with the Hex. Socket Screw Key 2 and take the file out.

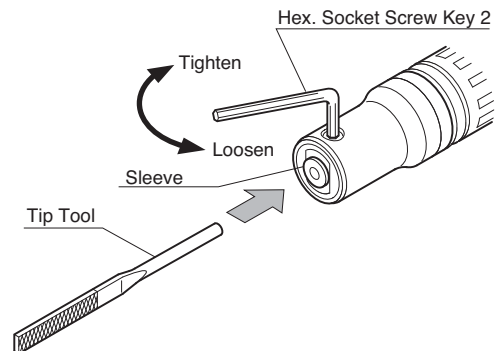

Fig.3

### 5-2. Start and Stop (Fig.5)

### ⚠ WARNING

- If the tool does not start after moving the Valve to ON,

(1) Move the Valve to OFF and disconnect the air hose from the supply line.

(2) Move the file in and out several times with your hand.(Fig.4)

(3) Dispense 5 drops of ISO VG-10 machine tool oil in the tools air hose.

(4) Reconnect to the air supply hose and move the Valve to ON.

Make sure the Valve is moved to OFF before connecting the air hose to the Cupla of this tool.

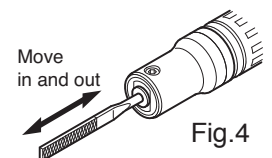

Fig.4

Start: Moving the Valve to the Housing side starts the tool. (Valve ON)  
 Stop: Moving the Valve to the Exhaust hose side stops the tool. (Valve OFF)

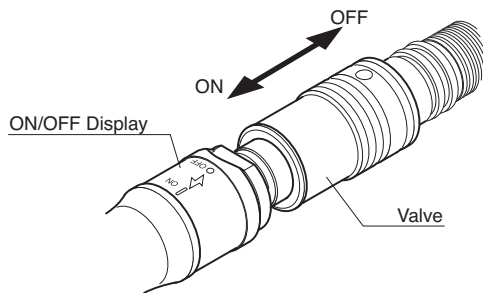

Fig.5

### 5-3. Filing operations

#### **! WARNING**

- Be sure to wear appropriate safety glasses and a dustproof mask during operation.
- Do not apply unnecessarily strong force. It may cause breakage of the file.

Start the tool, lightly press the File against the workpiece, and carry out the operation. Applying unnecessarily strong force to the File does not improve the work efficiency.

In addition, unnecessary force applied to the file may cause breakage of the File.

### 6. STORING TOOL

#### **! WARNING**

- When tool is not used, store it out of reach of children.

When the tool is not used, store it in a dry area. If the tool is left alone as it has been used without preparation for storage, ambient moisture will remain inside the tool, which will leave it susceptible to rusting. After finishing your work, add the machine oil ISO VG-10 through the Air Hose and run the tool for a while before storage.

### 7. ORDERING SERVICE PARTS

For further operational and handling information or for replacement of parts and components, contact the company from whom you purchased the tool or an authorized dealer.

In ordering parts and components give each part number, part name and quantity required.

Use only NITTO genuine parts.

## 8. OPTIONAL PARTS

Part No.	Description	Q'ty
TB09651	Flat File LF-13	1set (3 pcs.)
TB09652	Rat-Tail File LF-10	1set (3 pcs.)
TB09653	Half Round File LF-12	1set (3 pcs.)
TB09654	Triangular Taper File LF-11	1set (3 pcs.)

## 9. EXPLODED DIAGRAM : SHL-40

### WARNING

This diagram is for your reference only. Do not attempt to service or repair the Tool. Do not take the Tool apart. Contact an authorized Nitto dealer for all service and repair of the Tool. Improper service and repair can cause accidents and service injuries. Never attempt to modify the Tool. Never attempt service or repair the Tool.

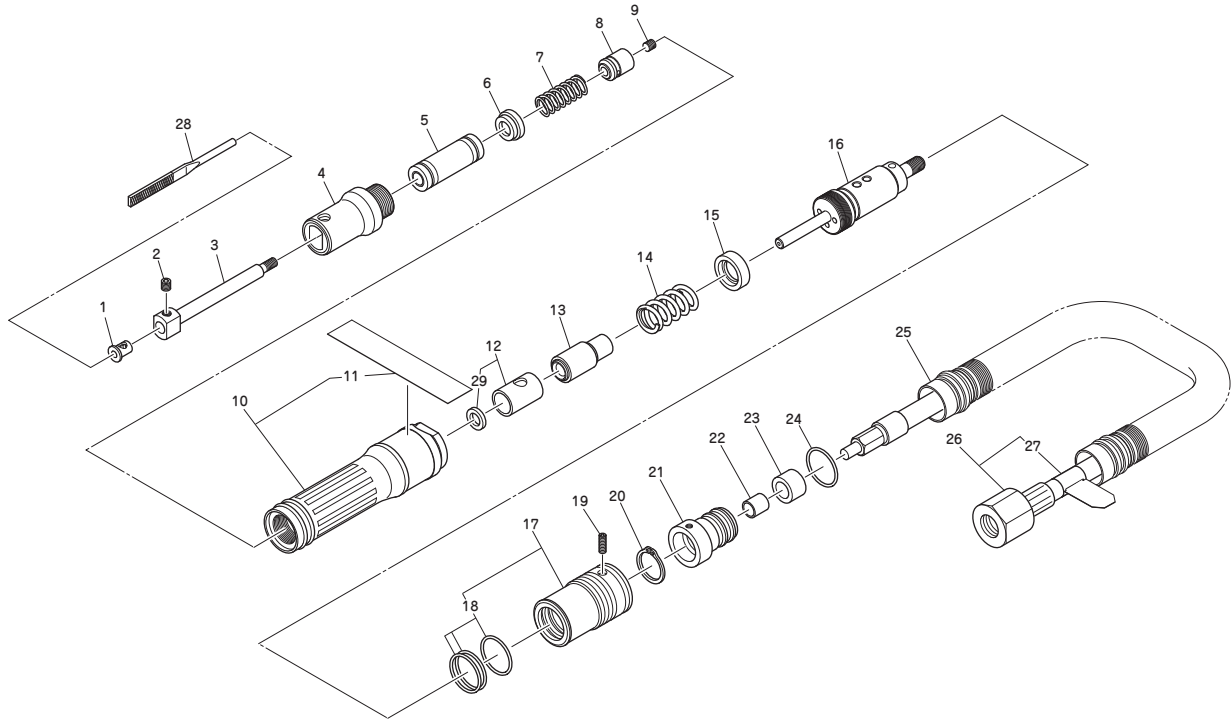

The part numbers with ( ) are included in the Ass'y parts written above them.

No.	Parts No.	Parts Name	Qty
1	TQ11133	Sleeve I.D. 3	1
2	TP04123	Hex. Socket Set Screw with Cup Point 4x4	1
3	TQ14037	Guide Shaft	1
4	TB09649	Guide Holder Sub Ass'y	1set
5	TQ11134	Slide Bearing	1
6	TQ14252	Spring Set Collar F	1
7	TQ11130	Spring 1x8x26	1
8	TQ11122	Piston	1
9	TP00639	Hex. Socket Set Screw with Flat Point 4x3	1
10	TB09710	Housing Ass'y	1set
11	(TQ14339)	Model Number Label	1
12	TB09646	Cylinder Ass'y	1set
29	(TQ13918)	Bushing	1
13	TB07500	Counter Weight Sub Ass'y	1set
14	TQ14253	Spring 1.3x11.2x22	1
15	TQ14038	Spring Set Collar R	1
16	TB07454	Valve Body Ass'y	1set
17	TB07455	Valve Sub Ass'y	1set

No.	Parts No.	Parts Name	Qty
18	(CP25836)	O-ring JASO-1016	3
19	TQ11158	Hex. Socket Set Screw with Cup Point 3x6	1
20	TP17226	External Retaining Ring ISTW-14	1
21	TQ11126	Hose Holder	1
22	TQ11127	Silencer Bushing	1
24	CP28152	O-ring JASO-1012	1
25	TQ04367	Exhaust Hose	1
26	TB08131	Air Hose K Ass'y	1set
27	(TQ11519)	Label Lubrication	1

#### Accessories

No.	Parts No.	Parts Name	Qty
	TP13892	Hex. Socket Screw Key 2	1
28	—	Flat File LF-13	1
	TQ14340	Instruction Manual	1
	TQ10966	Caution for Use	1
	TP02236	Bushing R1/4xNPT1/4	1
	TQ14341	Declaration of Conformity	1
	TQ11487	Attention for Start - up	1







## Overseas Affiliates / Offices

### NITTO KOHKI U.S.A., INC.

46 Chancellor Drive, Roselle, IL 60172 U.S.A.

Tel:(1)-630-924-9393 Fax:(1)-630-924-0303

### NITTO KOHKI EUROPE CO., LTD.

Unit 21, The Empire Centre Imperial Way,  
Watford Herts, WD24 4TS, U.K.

Tel:(44)-1-923-239668 Fax:(44)-1-923-248815

### NITTO KOHKI DEUTSCHLAND GMBH

Lerchenstr.47 D-71144 Steinenbronn, Germany

Tel:(49)-7-157-22436 Fax:(49)-7-157-22437

### NITTO KOHKI CO., LTD., SINGAPORE BRANCH

10 UBI CRESCENT #01-62,  
UBI TECHPARK LOBBY D, SINGAPORE 408564,

Tel:(65)-6227-5360 Fax:(65)-6227-0192

### NITTO KOHKI AUSTRALIA PTY. LTD.

77 Brandl St., Brisbane Technology Park,  
Eight Mile Plains QLD 4113 Australia

Tel:(61)-7-3340-4600 Fax:(61)-7-3340-4640

### NITTO KOHKI CO., LTD.,

#### BANGKOK REPRESENTATIVE OFFICE

M&A Business Center 38Q. House Convent Bldg.,  
7th Floor, Unit 7A, Convent Rd., Silom, Bangrak,  
Bangkok 10500 Thailand

Tel:(66)-2-632-0307 Fax:(66)-2-632-0308

### NITTO KOHKI (SHANGHAI) CO., LTD.

Room1506, suite C, Orient International Plaza,  
NO85 LouShanGuan Road, Shanghai, 200336, CHINA

Tel: (86)-21-6415-3935 Fax:(86)-21-6472-6957

### NITTO KOHKI CO., LTD.,

#### SHENZHEN REPRESENTATIVE OFFICE

2005C Shenzhen ICC Tower, Fuhuasanlu 168, Futian District,  
Shenzhen, Guangdong, 518048 China

Tel: (86)-755-8375-2185 Fax:(86)-755-8375-2187

## EC DECLARATION OF CONFORMITY

We hereby declare that the following our product conforms with the essential health and safety requirements of EU Directives.

Product: PORTABLE PRECISION FINISHING FILE

Model: SUPER HAND LIGHT:SHL-40

Serial No: In the case of 6 digits serial number.

X X X X X X

→ Consecutive numbers (00001~99999)

→ Last digit (0-9) of year (A.D.)

In the case of 7 digits serial number.

X X X X X X X

→ Consecutive numbers (00001~99999)

→ Last two digits (00-99) of year (A.D.)

Manufacturer: NITTO KOHKI Co., Ltd.

2-9-4, Nakaikagami, Ohta-ku, Tokyo, 146-8555, Japan

Authorised person to prepare the technical construction file(TCF) in the community:

Masatoshi Ogue

President

NITTO KOHKI EUROPE Co., Ltd.

Unit21, Empire Centre, Imperial Way, Watford Hertfordshire,  
WD24 4TS, UK

Tel:(44)-01923-239668 Fax:(44)-01923-248815

Directive: 2006/42/EC Machinery Directive

The above product has been evaluated for conformity with above directives using the following European standards. The technical construction file (TCF) for this product is retained at the above manufacturer's location.

Machinery Directive: EN ISO12100:2010, EN ISO11148-9:2011, others

Sound Pressure/Power Level: EN ISO15744:2008, EN ISO4871:1996

Vibration Level: EN28927-8:2009

Signature: \_\_\_\_\_

Date/Place: \_\_\_\_\_ /Tokyo, Japan

Name: K.Kishi

Title: GENERAL MANAGER MACHINE TOOLS DIV.

NITTO KOHKI Co., Ltd.

2-9-4, Nakaikagami, Ohta-ku, Tokyo, 146-8555, Japan

Being the responsible person appointed and employed the manufacturer.