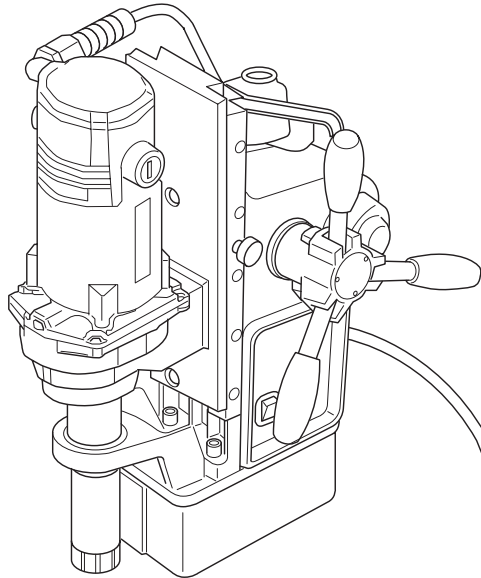

INSTRUCTION MANUAL

ATRAACE

Model: WA-5500

For One-touch Type Annular Cutter Only

[Specifications]

Model	WA-5500
Power Source	220-240 V AC 50/60 Hz
Rated Power Consumption	1040 W
No-load Speed	520 min ⁻¹
Max. Magnet Holding Power	9800 N (1000 kgf ^{*1})
Magnet Dimensions	101×203 mm
MASS (weight)	22 kg (excluding Power cord and Sub handle)

Cutter		Plate Thickness	Hole Diameter
JETBROACH One-touch Type	25L	9 to 25 mm	17.5 to 35 mm dia.
	35L	9 to 35 mm ^{*2}	17.5 to 40 mm dia.
	50L	9 to 50 mm ^{*2}	20 to 50 mm dia.
		9 to 35 mm ^{*2}	17.5 to 19.5 / 51 to 55 mm dia.
	75L	9 to 75 mm ^{*2}	20 to 50 mm dia.
		9 to 35 mm ^{*2}	17.5 to 19 mm dia.
HI-BROACH One-touch Type	25L	9 to 50 mm ^{*2}	51 to 55 mm dia.
		9 to 25 mm	14 to 50 mm dia.
	50L	9 to 50 mm ^{*2}	20 to 40 mm dia.
		9 to 35 mm ^{*2}	16 to 19 / 41 to 50 mm dia.

^{*1} The value in kgf is for reference only.

^{*2} Be sure to use the Chip Breaker when drilling holes with a plate thickness of 35 mm or more.

- Please read this manual carefully before you attempt to use your tool so that you may use it properly and safely.
- Keep the manual handy - so you can use it whenever necessary.

- Due to continuous product development/improvement, the specifications and configurations in this document are subject to change without prior notice.

Manufactured by.

NITTO KOHKI CO., LTD.

 2-9-4, Nakaikegami, Ota-ku, Tokyo 146-8555, Japan
 Tel : +81-3-3755-1111 Fax : +81-3-3753-8791

If you have any questions, contact us below.



Instructions



Thank you very much for your purchase of this NITTO KOHKI product.

Before using your tool, please read this manual carefully so that you may use it properly to get the most out of it.

Please keep the manual handy - so you can use it whenever necessary.

- English : Please ask your dealer or distributor for instruction manual in local language(s).
- German : Bitte fragen Sie Ihren Händler nach eine Betriebsanleitung in Landessprache.
- French : S'il vous plait, veuillez demandez á votre fournisseur de manuel instruction en langue locale.
- Spanish : Por favor, contacte con su distribuidor para el manual de instrucciones en español.
- Portuguese : Por favor pessa ao seo agente ou distribuidor o manual de instrucces ih linguagen local.
- Italian : Per Manuale Istruzioni in lingua locale Vi preghiamo di rivolgervi al rivenditore o distributore.
- Dutch : Vraag uw handelaar om een nederladstalige gebruiksaanwijzing.
- Swedish : Be er lokala Åtreförsäljare eller distributör om manualer på svenska.
- Danish : Venligst henvend Dem til den danske distributør for instructions manualer.
- Polish : Proszę pytać swojego dealera lub dystrybutora o instrukcje obsługi w języku localnym.
- 中文 : 請向當地供應商或經銷商詢問中文使用說明書

The following Safety notations are used throughout the manual to highlight safety precautions for the user and for the tool.

	DANGER:	Indicates an imminently hazardous situation which, if not avoided by following the instructions given, will result in death or serious injury.
	WARNING:	Indicates a potentially hazardous situation which, if not avoided by following the instructions given, could result in death or serious injury.
	CAUTION:	Indicates a potentially hazardous situation which, if not avoided by following the instructions given, could result in injury or material damage.

* Please note, however, that failure to observe safety precautions under the " CAUTION" category could result in a serious occurrence depending on the situation.

Please observe all safety precautions in the manual.

CAUTION: Important precautions for tool setup, operation and maintenance.

About pictograms



WARNING: It might be dangerous to operate the tool if the instructions supplied are not followed.



Read the instruction manual before use.



Always wear suitable eye protection.



Always wear suitable hearing protection.



Always wear respiratory protective equipment (PPE).

Sound Pressure Level (LPA)	81 dB (A) According to EN 62841-1
Sound Power Level (LWA)	92 dB (A) According to EN 62841-1
Uncertainty K	0.71 dB (A) Operating Condition: No load
Vibration Emission Value ah	0.75 m/s ² According to EN 62841-1 Location: Rod Handle
Storage Temperature	-10°C to 60°C (no freezing)
Storage Humidity	Max. 90% at 25°C (no dewing)
Operating Temperature	5°C to 40°C
Operation Altitude	1000 m Max.
Operating Humidity	Max. 90% at 25°C
Over-voltage Category	Category II According to IEC60664-1
Pollution Degree	Degree 3 According to IEC60664-1
International Protection	IP20 According to IEC60529

Contents

Precautions on Use (Make sure to follow the instructions given).....	2	7 Troubleshooting.....	26
General Power Tool Safety Warnings.....	2	8 Maintenance and Inspection.....	27
Drill Safety Warnings.....	4	Keeping the Drill Motor at the Lifted-Up Position.....	27
General Safety Warnings.....	4	Periodic Application of Grease to Sliding Surface.....	27
Power Tool Safety.....	7	Adjustment of Loose Slide Board.....	27
Product Specific Safety Rules.....	8	Bracket Inspection.....	27
1 Application.....	13	Keeping the Tip of Pilot Pin Sharp.....	27
2 Checking Inside the Package.....	13	Recovery Measures When Pilot Pin Gets Jammed.....	28
3 Part Names.....	14	Cutter Regrinding.....	28
4 Function of Electronic Control.....	15	Carbon Brushes Inspection and Replacement...28	
Load Detection Function.....	15	Storing the tool.....	28
Cycle Stop Function.....	15	Disposal.....	28
Lower Limit Stop Function.....	15	9 Optional Parts.....	29
Motion Detection Function.....	15	NITTO KOHKI Brand Cutting Oil.....	29
Fail-safe Restart Function.....	15	Supporting Magnet Ass'y.....	29
Magnet Open-circuit Sensor.....	15	Sleeve 6.5 Ass'y Twist Drills.....	29
5 Preparation.....	16	Pilot Pin.....	29
Accessory Installation.....	16	Cutter.....	30
Using Cutter.....	16	10 Ordering Parts.....	31
Combination of Cutter and Pilot Pin.....	16	11 Exploded View/Parts List.....	32
Attachment and Detachment of Cutter.....	17	WA-5500 Exploded View/Parts List.....	32
Preparation of Chip Breaker.....	18		
Preparation of Cutting Oil / Cutting Oil Safety Precautions.....	19		
Connecting the Power Supply Plug to Power Source.....	20		
6 Basic Operation.....	21		
Starting and Stopping.....	21		
Drilling Procedure.....	22		
Drilling Oblong Hole.....	25		
Using Manual Feed for Drilling Laminated Plates.....	25		

California Proposition 65

WARNING

Some dust created by power sanding, sawing, grinding, drilling, and other construction activities contains chemicals known [to the State of California] to cause cancer birth defects or other reproductive harm. Some examples of these chemicals are:

- Lead from lead-based paints,
- Crystalline silica from bricks and cement and other masonry products, and
- Arsenic and chromium from chemically-treated lumber.

Your risk from these exposures varies, depending on how often you do this type of work. To reduce your exposure to these chemicals: work in a well ventilated area, and work with approved safety equipment, such as those dust masks that are specially designed to filter out microscopic particles.

Precautions on Use (Make sure to follow the instructions given)

Before using your tool, to avoid personal injury always take the basic precautions explained in later sections.

General Power Tool Safety Warnings

WARNING

- **Read all safety warnings, instructions, illustrations and specifications provided with this power tool.**
Failure to follow all instructions listed below may result in electric shock, fire and/or serious injury.
- **Save all warnings and instructions for future reference.**
The term "power tool" in the warnings refers to your mains-operated (corded) power tool or battery-operated (cordless) power tool.

(1) Work area safety

- **Keep work area clean and well lit.**
Cluttered or dark areas invite accidents.
- **Do not operate power tools in explosive atmospheres, such as in the presence of flammable liquids, gases or dust.**
Power tools create sparks which may ignite the dust or fumes.
- **Keep children and bystanders away while operating a power tool.**
Distractions can cause you to lose control.

(2) Electrical safety

- **Power tool plugs must match the outlet. Never modify the plug in any way. Do not use any adapter plugs with earthed (grounded) power tools.**
Unmodified plugs and matching outlets will reduce the risk of electric shock.
- **Avoid body contact with earthed or grounded surfaces, such as pipes, radiators, ranges and refrigerators.**
There is an increased risk of electric shock if your body is earthed or grounded.
- **Do not expose power tools to rain or wet conditions.**
Water entering a power tool will increase the risk of electric shock.
- **Do not abuse the cord. Never use the cord for carrying, pulling or unplugging the power tool. Keep cord away from heat, oil, sharp edges or moving parts.**
Damaged or entangled cords increase the risk of electric shock.
- **When operating a power tool outdoors, use an extension cord suitable for outdoor use.**
Use of a cord suitable for outdoor use reduces the risk of electric shock.
- **If operating a power tool in a damp location is unavoidable, use a residual current device (RCD) protected supply.**
Use of an RCD reduces the risk of electric shock.

(3) Personal safety

- **Stay alert, watch what you are doing and use common sense when operating a power tool. Do not use a power tool while you are tired or under the influence of drugs, alcohol or medication.**
A moment of inattention while operating power tools may result in serious personal injury.

WARNING

- **Use personal protective equipment. Always wear eye protection.**
Protective equipment such as a dust mask, non-skid safety shoes, hard hat or hearing protection used for appropriate conditions will reduce personal injuries.
- **Prevent unintentional starting. Ensure the switch is in the off-position before connecting to power source and/or battery pack, picking up or carrying the tool.**
Carrying power tools with your finger on the switch or energizing power tools that have the switch on invites accidents.
- **Remove any adjusting key or wrench before turning the power tool ON.**
A wrench or a key left attached to a rotating part of the power tool may result in personal injury.
- **Do not overreach. Keep proper footing and balance at all times.**
This enables better control of the power tool in unexpected situations.
- **Dress properly. Do not wear loose clothing or jewelry. Keep your hair and clothing away from moving parts.**
Loose clothes, jewelry or long hair can be caught in moving parts.
- **If devices are provided for the connection of dust extraction and collection facilities, ensure these are connected and properly used.**
Use of dust collection can reduce dust-related hazards.
- **Do not let familiarity gained from frequent use of tools allow you to become complacent and ignore tool safety principles.**
A careless action can cause severe injury within a fraction of a second.
- **Keep handles and grasping dry, clean and free from oil and grease.**
Slippery handles and grasping surfaces do not allow for safe handling and control of the tool in unexpected situations.

(4) Power tool use and care

- **Do not force the power tool. Use the correct power tool for your application.**
The correct power tool will do the job better and safer at the rate for which it was designed.
- **Do not use the power tool if the switch does not turn it ON and OFF.**
Any power tool that cannot be controlled with the switch is dangerous and must be repaired.
- **Disconnect the plug from the power source and/or remove the battery pack, if detachable, from the power tool before making any adjustments, changing accessories, or storing power tools.**
Such preventive safety measures reduce the risk of starting the power tool accidentally.
- **Store idle power tools out of the reach of children and do not allow persons unfamiliar with the power tool or these instructions to operate the power tool.**
Power tools are dangerous in the hands of untrained users.
- **Maintain power tools and accessories. Check for misalignment or binding of moving parts, breakage of parts and any other condition that may affect the power tool's operation. If damaged, have the power tool repaired before use.**
Many accidents are caused by poorly maintained power tools.
- **Keep cutting tools sharp and clean.**
Properly maintained cutting tools with sharp cutting edges are less likely to bind and are easier to control.
- **Use the power tool, accessories and tool bits etc. in accordance with these instructions, taking into account the working conditions and the work to be performed.**
Use of the power tool for operations different from those intended could result in a hazardous situation.
- **Keep handles and grasping surfaces dry, clean and free from oil and grease.**
Slippery handles and grasping surfaces do not allow for safe handling and control of the tool in unexpected situations.

(5) Service

- **Have your power tool serviced by a qualified repair person using only identical replacement parts.**
This will ensure that the safety of the power tool is maintained.

Drill Safety Warnings

⚠ WARNING

- Do not wear gloves. Gloves may be entangled by the rotating parts or chips leading to personal injury.
- Keep your hands out of the drilling area while the tool is running. Contact with rotating parts or chips may result in personal injury.
- Never remove chips from the drilling area while the tool is running. To remove chips, move the accessory away from the workpiece, switch off the tool and wait for the accessory to stop moving. Use tools such as a brush or hook to remove chips. Contact with rotating parts or chips may result in personal injury.

General Safety Warnings

Personal safety

⚠ WARNING

- **Dress properly.**
Do not wear loose clothing or jewelry. There is a danger of being caught in moving parts. Wear a pair of non-slip shoes. If your hair is long, wear a protective hair covering to contain your hair.
- **Always wear eye protection.**
Corrective glasses are not considered eye protection. Always wear appropriate eye protection.
- **Wear a dust mask.**
When dust is generated in the workplace, wear a dust mask.
- **Use a dust collector or dust collection equipment correctly.**
If a dust collector or dust collection equipment are being used, check that these are connected and used properly. Use of a dust collector can reduce risk caused by dust.
- **When loud noise is generated in the workplace, wear earplugs.**
- **Do not overreach.**
Keep proper footing and balance at all times.
- **Be on your guard when working.**
Do not use the tool when you are tired.
When you use the tool, be sure about the handling method, how to work and pay sufficient attention to the surrounding environment.
- **Never touch the tip of moving parts when the tool is running.**
Also, do not direct the tip of moving parts toward people or animals.
- **Be aware of tool vibration and recoil. Some tools can cause a considerable amount of vibration.**
Depending on how the product is operated, the type of tool setting, and the length of operation, it could place a tremendous burden on your hands, arms and body. The tool could cause a vibration injury or tendonitis. Avoid long-term use and take appropriate breaks. Consult a doctor if you experience any discomfort or pain while operating the tool.

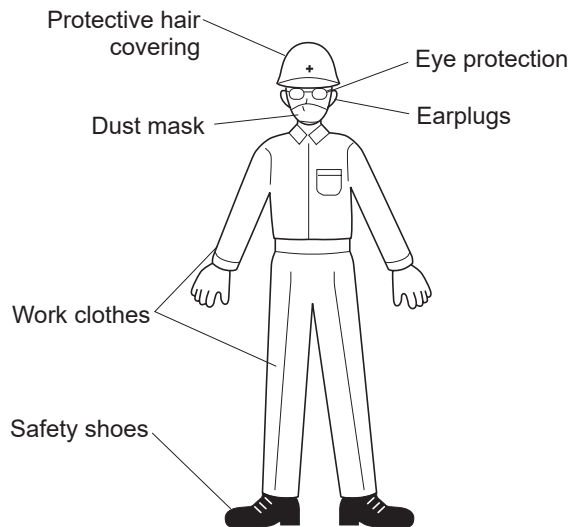

Work area safety

⚠ WARNING

- **Do not use the tool at home.**
This is a professional tool (industrial or work tool for business). Do not bring the tool home and use it there.
- **Keep the work area clean.**
Working in a messy work area or work table could cause an accident.
- **Be cautious about the work area.**
Do not expose the tool to rain.
Do not use the tool in a damp or wet place.
Keep the work area well lit.
- **Do not operate the tool in an explosive atmosphere, such as in the presence of flammable liquids (thinner, lacquer, gasoline, etc.) or gas.**
- **Do not let children come close to the work area.**
Keep children and bystanders away while operating the tool.
- **Some tools generate loud noise.**
Check that the noise regulations of each area are complied with.
- **When work has to be done in high locations, make sure there is nobody underneath the work area.**
If the tool or material is dropped, it could cause an accident or injury.
- **Before starting operation, make sure that there is no conduit, water pipe or gas pipe by your work area.**
If a tool touches a buried object, it could cause electrical shock or leakage, which could cause an accident.



Before starting to work

⚠ WARNING

- **Perform inspection before using the tool.**
Before using the tool, check for loose screws on the tool and for damage on the protective cover or other parts, and make sure that the tool operates normally and demonstrates prescribed functions.
Check the position adjustment and tightening status of moving parts, parts damage, attachment status, and all other locations for issues that could affect operation.
For parts replacement and repair, follow the instructions indicated in the instruction manual.
If there are no instructions in the instruction manual, contact the retailer where you purchased the tool or the nearest NITTO KOHKI's overseas affiliates/offices (see the back cover of this manual).
Do not use the power tool if the switch does not turn it ON and OFF.
- **Make sure to properly attach the tip tool.**
If the tip tool is not attached properly, there is a risk of jumping out or damage, which could result in injury.
- **After adjustment, be sure to remove tools such as spanners, wrenches, etc.**
- **Use appropriate tools.**
Do not force small tools to do the job of a heavy-duty tool. Do not use tools for purposes not intended.
- **Do not use tools in an unreasonable manner.**
When the specifications are followed, tools can be used efficiently and safely.
- **Secure workpieces.**
Where possible use clamps or a vise to hold the work. It is safe to hold the workpieces by clamps or a vise since both hands can be used for operation.

Handling tools

WARNING

- **Store the tool in an appropriate location.**
When the tool is not used, store the tool in a dry location. Also, store the tool out of the reach of children. For some tools, the storage temperature and humidity are specified.
- **Be cautious about how the tool is carried.**
Do not carry the tool with your hand touching the operation switch.
- **Do not leave the tool while the tool is still running.**
Do not leave the work area until you turn OFF the operation switch, remove the power source and the tool completely stops.
- **Do not allow the following chemicals to come into contact with the tool, as parts could deteriorate.**
Acetone, benzine, thinner, ketone, ether, trichloroethylene and other similar chemicals.

Maintenance and inspection

WARNING

- **Do not disassemble or alter the tool.**
Using the tool after disassembling or remodeling it could cause an accident or injury.
- **Inspect tip tools and accessories.**
Always inspect tip tools and accessories for damage or deterioration before attaching them to the tool. If damage or deterioration is found, request repair from the retailer where you purchased the tool or the nearest NITTO KOHKI's overseas affiliates/offices (see the back cover of this manual).
- **Inspect for damaged sections.**
Sufficiently check for damage on accessories or other parts, that the tool operates normally, and that work can be performed appropriately.
If there are accessories or parts that have been damaged or could hinder work, request repair from the retailer where you purchased the tool or the nearest NITTO KOHKI's overseas affiliates/offices (see the back cover of this manual).
- **Request repair from a dedicated store.**
For repair or replacement of parts, request service from the retailer where you purchased the tool or the nearest NITTO service member store.
Repair requires special knowledge and skills. If repair is performed at a place other than a specialty store, the tool may not demonstrate its full performance or it could lead to an accident or injury.
Request repair with the failed status kept intact. When requesting a repair, do not throw away damaged parts. It could be important information for investigating the failure cause so do not change the status.
- **Use genuine parts.**
If inappropriate parts are used, it could cause an accident or injury.
Genuine parts are listed in the instruction manual or brochure. Inquire at the retailer where you purchased the tool or the nearest NITTO KOHKI's overseas affiliates/offices (see the back cover of this manual).
- **Do not remove the labels or plates on the tools.**
If labels or plates are broken or peeling, for a replacement label or plate contact the retailer where you purchased the tool or the nearest NITTO KOHKI's overseas affiliates/offices (see the back cover of this manual).

Power Tool Safety

WARNING

- **Always use a power supply that provides the power displayed on the label or nameplate.**
Using other than the displayed power supply could result in an accident or injury due to failure or abnormal operation.
- **Use a sine wave power supply with a power fluctuation rate within $\pm 10\%$ of the rated power supply and a frequency of 50/60 Hz.**
- **Make sure the tool has been properly grounded.**
If the tool is not properly grounded, it could result in an electric shock.
- **Make sure there is no problem in the ground clip and ground wire.**
If a tester or insulation resistance meter is available, perform a conductivity check between the ground clip and the metal part of the tool. The specialized knowledge of a qualified electrical engineer is required to connect a wiring including the installation of a ground rod or plate on the ground. The customer must not try connecting the wiring on their own. Contact the nearest electrical engineering company.
- **Do not connect the ground wire to the gas piping.**
This could result in explosion or serious injury, or even death.
- **Be cautious about electric shock.**
Do not touch the power plug with wet hands. Doing so could cause an electric shock. While using the tool, make sure that your body does not touch any grounded objects. (For example, the exterior of factory piping, heating equipment, microwave oven, refrigerator, etc.)
- **Before using the tool, make sure an earth leakage circuit breaker for the prevention of electric shock has been attached to the power supply to which the tool is to be connected, according to the requirements of the Ordinance on Industrial Safety and Health and/or the Technical Standards for Electrical Equipment.**
Not using an earth leakage circuit breaker could result in an electric shock.
- **Do not start the tool suddenly.**
Before connecting the power plug to the power supply, confirm that the switch is turned OFF.
- **When performing preparation, maintenance and inspection, turn OFF the switch and disconnect the power plug from the power supply.**
Not disconnecting the connection to the power supply during preparation, inspection, or maintenance could result in an accident or serious injury.
- **Do not handle the power cord in a rough manner.**
Do not carry the tool by holding the power cord or pull on the power cord to disconnect it from the outlet. Do not damage the power cord, such as by modifying it, bending it to an excessive degree, using it close to high-temperature objects, placing heavy objects on it, pinching the cord between objects, or hanging the cord on metal objects. Do not pull, twist, or tightly wrap the cord.
- **Do not store the power cord by wrapping it around the main unit.**
Doing so could damage the power cord.
- **Periodically inspect the power cord and power plug for damages, and if damage is found, stop using the tool.**
Using a damaged power cord or power plug could cause a fire or electric shock.
- **Do not modify commercially available power cords and power plugs and attach them to the tool.**
Use only the genuine power cord and power plug. To replace the power cord, contact the dealer where you purchased the tool, or the nearest authorized seller.
- **Make sure the power plug does not have any dust or metal material adhering to it.**
If dust or metal material is found on the power plug, disconnect the power plug and wipe it away with a dry cloth. If the tool is used without removing such material, it could cause a fire or electric shock.
- **Plug in the power plug securely all the way into the outlet.**
An improperly connected power plug could overheat, and dust adhering to the plug could cause a fire or electric shock. Metal pieces adhering to an improperly connected power plug could also result in a fire or electric shock.
- **Do not connect the power plug to a loose outlet.**
Doing so could cause a fire or electric shock.
- **When exchanging the tip tool, ensure that the power plug is disconnected.**
- **When connecting the tool to wiring equipment (extension cord, coil drum etc.) or electric equipment, follow the instruction manual for the equipment.**

⚠ WARNING

- **When using an extension cord, inspect it periodically.**
If the extension cord is damaged, replace it.
- **If using the tool outdoor, use an extension cord intended for outdoor use.**
- **If the tool is dropped or hit, check to ensure there is no breakage, cracking, or deformation.**
Breakage, cracking, or deformation could cause electric shock or injury.
- **When the tool becomes overheated or you notice anything abnormal, stop using the tool immediately and request that the tool be repaired.**
- **The noise-emission value in this manual is measured in accordance with the ISO standards.**
The value may be also used for comparing this tool with another and in a preliminary assessment of exposure. However, since the real value may change depending on the work condition, perform measurements in the actual usage condition when using the tool. Do not operate the tool beyond the time set by the region where the tool is used.
- **The vibration value in this manual is measured in accordance with the ISO standards.**
The value may be also used for comparing this tool with another and in a preliminary assessment of exposure. However, since the real value may change depending on the work condition, perform measurements in the actual usage condition when using the tool. Do not operate the tool beyond the time set by the region where the tool is used.

Product Specific Safety Rules

⚠ DANGER

- **Do not use your tool on the ceiling.**
Use of the tool on the ceiling is dangerous. The tool could fall. The falling tool could cause severe injuries or death.

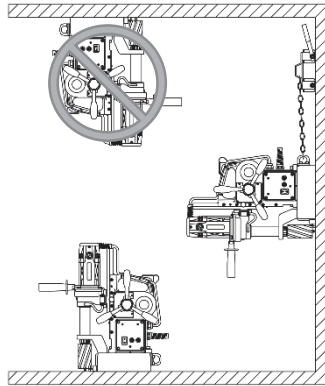

⚠ WARNING

- **Do not use the Magnet for more than five hours.**

More than five hours of uninterrupted operation may cause a fire. Five hours of uninterrupted operation generates extreme heat in the Magnet and permanently damage the internal coils. Do not touch the Magnet when the Magnet is hot. Touching it will cause a severe burn injury. When you are not using the Magnet, turn the switch to the OFF position and unplug the tool.

- **Do not use the Drill Motor for over 30 minutes.**

Uninterrupted operation of the Drill Motor for over 30 minutes generates heat. This heat can cause a fire. When you are not using the Drill Motor, turn the switch to the OFF position and unplug the tool.

- **Use only on magnetic materials.**

Your tool cannot be used on non-magnetic materials, such as aluminum, stainless steel, copper or alloys. The Magnet will not adhere on non-magnetic materials. Attempting to use the Magnet on non-magnetic materials could cause an accident.

- **Use caution during wall operation.**

When using your tool on a wall, always use caution.

Never stand under the tool.

* Never allow anyone to stand under the tool.

* Never put any part of your body under the tool.

* If the tool falls, it could result in severe injury or death.

Always remove Cutting Oil from the Tank before using the tool on a wall. You must manually apply Cutting Oil to the cutting tool.

- **Always use a workpiece that is at least 9 mm thick.**

The workpiece must be at least 9 mm thick. If a workpiece is too thin, the magnetic power of your tool will decrease.

This will cause the tool to move during operation. This could result in an accident.

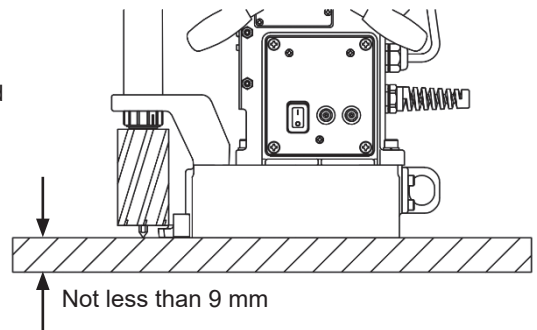

⚠ WARNING

- **Use an iron back-up plate.**

If the workpiece is less than 9 mm thick, you must use an iron back-up plate that is more than 10 mm in thickness. The surface area of the iron back-up plate must be greater than the surface area of the magnet. An appropriate back-up plate is necessary to boost the holding power of the Magnet. Use of an inappropriate back-up plate can result in an accident. If the back-up plate is not thick enough or big enough, the tool will come loose during operation. This can result in an accident and severe injuries.

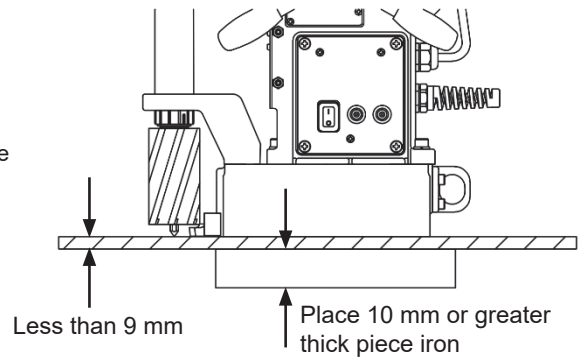

- **Always keep surfaces clean.**

Always keep the Magnet surface clean. Always keep the workpiece surface clean. If there are any foreign objects between the Magnet and the workpiece surfaces, this will reduce magnetic power. This could cause the tool to move during operation. This can result in an accident. Keep all surfaces clean of rust, chips or other foreign material.

- **Do not place the tool over a hole.**

Do not attempt to position the Magnet over a hole. Attempting to straddle a hole will reduce the power of the Magnet. This will cause the workpiece to come loose during operation and can cause an accident.

- **Always use a chain to secure the tool.**

If the tool falls, it can cause severe injuries. There is always a possibility that magnetic power can be lost or reduced because of a power failure. Magnetic power can be lost on rough surfaces. You must take precautions to prevent the tool from falling.

This tool comes with a chain. The chain is to be used to fasten the tool to the workpiece. If you do not use the chain, it is possible that the tool may fall.

If use of the chain is not possible because of the size of the workpiece, you must use another method of securing the tool. Use a Supporting Magnet Ass'y to prevent the tool from falling. The use of a Supporting Magnet Ass'y is shown in the figure.

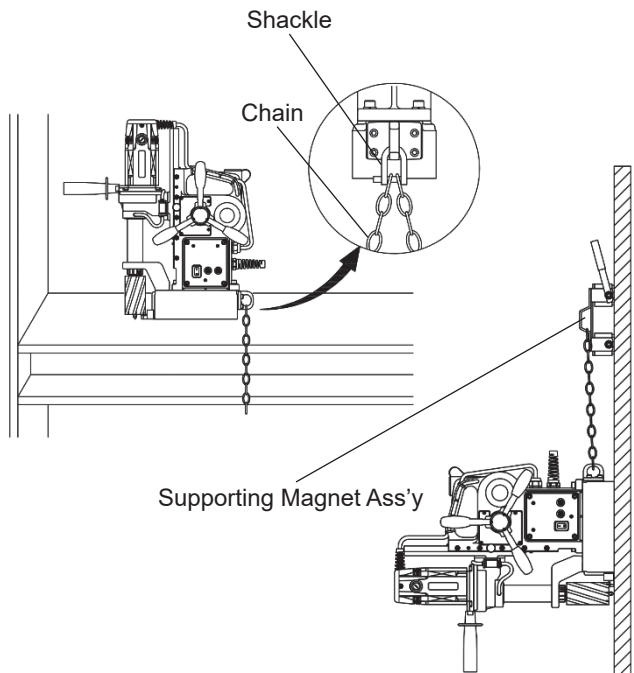

⚠ WARNING

- **Always set the Magnet in the proper position.**

Always set the Magnet parallel to the longitudinal direction of the material. Failure to set the Magnet in the proper position may result in reduced magnetic power. This can cause the tool to move in operation. This can cause an accident resulting in severe injuries. When using on H-section steel, as shown in the figure on the right, set the Magnet in a direction parallel to the longitudinal direction of the material. This will ensure that the Magnet is in the best position for magnetic attraction. Poor magnetic power may result in damage to the Cutter or damage to the workpiece.

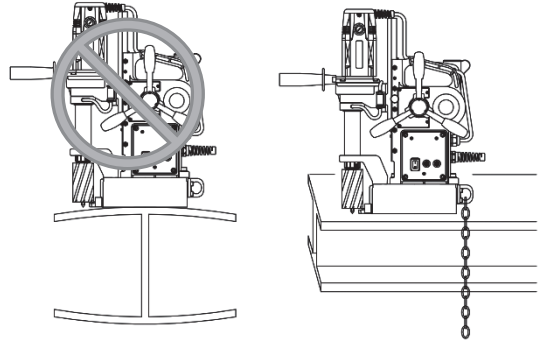

- **Be careful about chips.**

Keep your hands away from the cutting area at all times. During drilling, there will be chips. The chips are sharp. The chips are rotating with the Cutter. Any contact with the chips can cause severe injuries.

- **Do not touch the Slug.**

The Slug is very hot and sharp. It will cause severe burns. Make sure that no one touches the Slug. Make sure that there is no one below the work area during operation. Hot Slugs will fall. Hot Slugs can cause severe burns, other severe injuries, or even death. Always wear protective equipment, including protective headgear, eye protection, hearing protection, and gloves. Do not allow any person without protective equipment to come near the tool.

- **Do not use your hands to remove chips.**

Chips have sharp edges. Use a screwdriver to remove chips. If you use your hands to remove chips, you can be injured, even if you are wearing gloves. Do not use your hands to remove chips under any circumstances.

- **The cutting edge is sharp.**

Always wear gloves when changing the Cutter. The cutting edge is sharp. If you do not wear gloves, you will be cut. Attempting to change the Cutter can result in severe injuries.

- **Do not use Cutting Oil for other purposes.**

Cutting Oil should be used only for drilling. Please refer to Section 5 Cutting Oil Safety Precautions of this manual for further warnings and instructions about Cutting Oil.

- **Stop the work and inspect the tool when abnormal spark is observed with the carbon brushes of the tool.**

⚠ CAUTION

- **Always use a compatible Pilot Pin.**

The Pilot Pin must be compatible with the Cutter. An improper Pilot Pin may result in an accident. See Section 5 Combination of Cutter and Pilot Pin to identify compatible Pilot Pins and Cutters. The proper Pilot Pin to be used will vary, depending on the type of Cutter, the diameter of the Cutter, and the length of the Cutter.

- **Do not use power that is generated by an engine-driven welder.**

The use of an engine-driven welder as a power source may cause your tool to malfunction. Power from an engine-driven welder can damage the electronic circuits in your tool.

- **Do not use an extension cord that is too thin. Do not use an extension cord that is too long. Do not use an extension cord that is wound on a drum. Do not share an extension cord with other motor-driven tools.**

These uses can cause voltage to drop and can reduce the holding power of the magnetic base, causing the tool to move during operation. This can decrease performance and may cause damage to the tool.

- **Use a Proper extension cord.**

Max length	Size (nominal cross-section area of the conductor)
10 m	1.25 mm ² or more
15 m	2.00 mm ² or more
30 m	3.50 mm ² or more

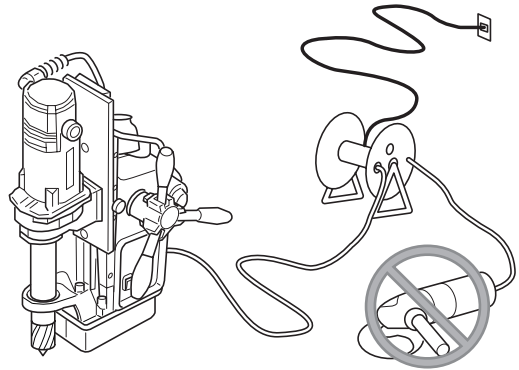

- **Do not use this tool on the steel material being electrically welded.**

When the electric welder is not properly grounded, electricity will run through the tool via its Magnet and Power cord, causing possible failure or malfunctioning, which in turn may cause an accident.

- **Do not force to feed Cutter when drilling manually.**

Because the HI-BROACH and JETBROACH have rather thin cutting edges with less cutting pressure resistance as compared to twist drill, do not force to feed the Cutter when drilling manually.

If you feed it with too much force, the Cutter may break or end up with shorter life.

- **Lower the Drill Motor when not using to store the tool.**

The main unit may turn over when the Drill Motor is kept in lifted position.

- **Do not switch from manual to automatic operation while drilling holes.**

If you wish to drill a hole using automatic feed, start with automatic feed. If you are drilling a hole with manual feed and switch to automatic feed in the middle, the Drill Motor may stop.

- **When the automatic feed is ON, do not feed manually.**

With automatic feed ON (with the Rod Handles pushed towards the body), do not put additional feed pressure on the Rod Handles.

1 Application

This is a portable drilling machine with a Magnet, geared to drill mild steel (mild steel or equivalent). The tool will be mounted on the workpiece to be drilled with the Magnet securely fastening the tool to the workpiece while drilling takes place.

2 Checking Inside the Package

When you open the package box, check the contents of the package and also check for any damage that may have occurred during transportation.

If an abnormality is found, request service from the retailer where you purchased the tool or the nearest office of Nitto Kohki Group.

	Package Contents	Qty	Check
①	WA-5500 (main unit)	1	
②	Cutting Oil 0.5L Ass'y	1	
③	Pilot Pin 08050	1	
④	Hex. Socket Screw Key 3	1	
⑤	Hex. Socket Screw Key 4	1	
⑥	Spanner 8×10	1	
⑦	Sub Handle	1	
⑧	Guard	1	
⑨	Chain	1	
⑩	Instruction Manual	1	
⑪	Carrying Case Ass'y	1	

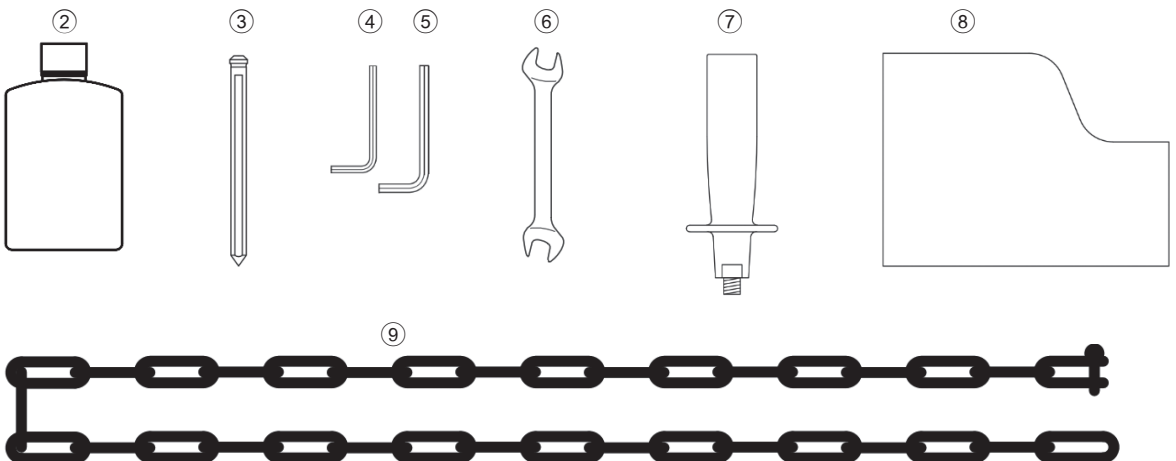
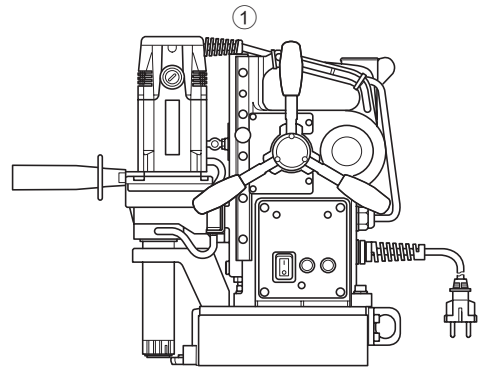

3 Part Names

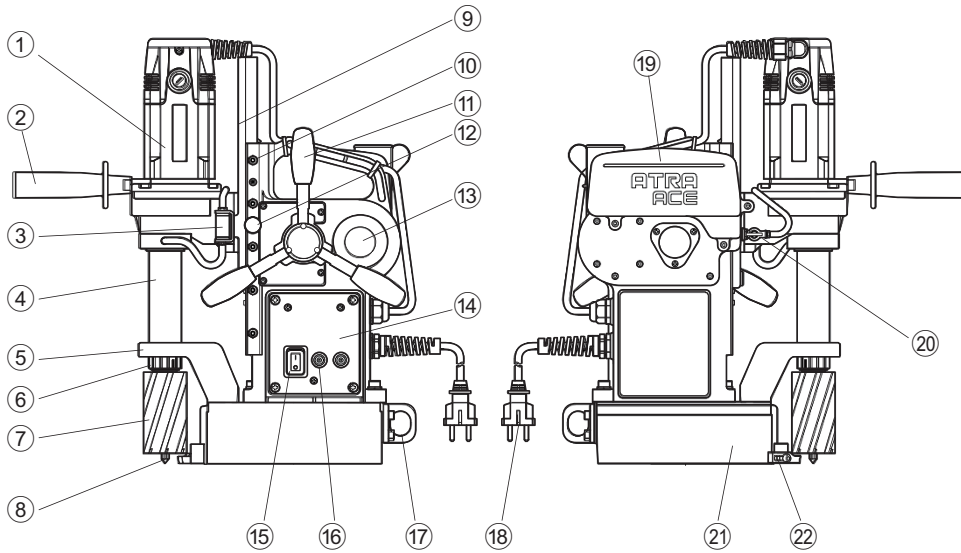

- | | |
|---------------------------------|-----------------|
| ① Drill Motor | ⑫ Set Screw |
| ② Sub Handle | ⑬ Body |
| ③ Oil Dropper | ⑭ Switch Plate |
| ④ Arbor Body | ⑮ Magnet Switch |
| ⑤ Bracket | ⑯ Motor Switch |
| ⑥ Sleeve | ⑰ Chain Guide |
| ⑦ Cutter | ⑱ Plug |
| ⑧ Pilot Pin | ⑲ Oil Tank |
| ⑨ Slide Board | ⑳ P-Valve |
| ⑩ Slide Board Adjustment Screws | ㉑ Magnet |
| ⑪ Rod Handle | ㉒ Blade |

4 Function of Electronic Control

Load Detection Function

The tool automatically operates functions described below when excessive load is applied in drilling. Do not use the tool with an engine generator as the power source or when the voltage of the power source is too high or low since the load detection function may not operate properly.

Function Name	Description
Automatic Feed Control Function	This system automatically controls the feed rate where several seconds after start-up of the drilling. The system automatically slows down the feed and the rate varies depending on the load condition of the Drill Motor. The feed rate is also automatically regulated according to the Cutter diameter.
Overload Stop Function	Both the drilling and feeding operations stop automatically whenever there is an excessive load on the Drill Motor, preventing the Drill Motor and Cutter from break. If the Cutter is dull, however, breakage may be inevitable.

Cycle Stop Function

After the cut has finished, a detector responds to the reduction in load and both the Drill Motor and the feed motor automatically stop.

Lower Limit Stop Function

Even when the Drill Motor fails to automatically stop downward feed at the end of drilling, both the Drill Motor and the feed are stopped when the stroke reaches the lower limit.

Motion Detection Function

If the Magnet slides off while drilling holes, the Drill Motor will stop and the feed will stop.

Fail-safe Restart Function

- When a power failure has occurred while the tool was being used, the restart prevention function operates when the power is restored.
- Even when the Drill Motor stops during operation because of the interruption of the power supply or accidental unplugging of the power supply and the power supply resumes, or is plugged, the indicator lamps are lit and the magnet regains its attracting power, but the Drill Motor does not rotate.
- To resume work, set the Magnet Switch to ON and then the Motor Switch to ON, and the Drill Motor will start.

Magnet Open-circuit Sensor

When the Magnet fails, the Drill Motor will not start. To repair defective Magnet, please contact the retailer where you purchased the tool or the nearest office of Nitto Kohki Group.

5 Preparation

⚠ WARNING

- When setting up tool, turn OFF the Magnet Switch and disconnect the power supply plug from power source.

Accessory Installation

The Sub Handle, an Accessory, should be mounted on the Drill Motor. When you carry the tool to other spots, please hold up the tool with the grip of the tool and the Sub Handle of the Drill Motor.

Using Cutter

⚠ CAUTION

- Cutters other than One-touch Type cannot be used.
- For better workability and safety, do not use worn or damaged Cutters.

When you need One-touch Type Cutters or accessories, see 9 Optional Parts.





Combination of Cutter and Pilot Pin

⚠ CAUTION

- Do not use any other combinations than those shown in the compatibility table.

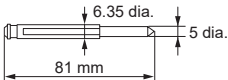
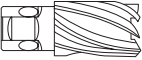
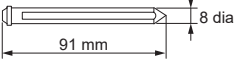
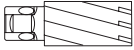
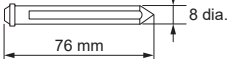
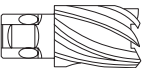
Use a Pilot Pin appropriate for the Cutter.

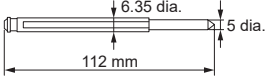
A Pilot Pin to be used varies depending on the Cutter type, diameter, length (depth). A wrong combination of Cutter and Pilot Pin would not allow Slug to be ejected at the end of drilling and/or prevent Cutting Oil from reaching the cutting point, resulting in cutting tool damage.

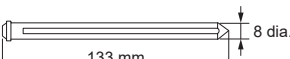
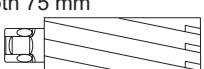
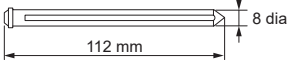
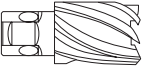
Pilot Pin	HI-BROACH Cutters	Pilot Pin	JETBROACH Cutters
06025 PN:TK01167 	Cutter dia. 14 to 17 mm Depth 25 mm 	08035 PN:TK01487 	Cutter dia. 17.5 to 40 mm Depth 35 mm 
08025 PN:TK01486 	Cutter dia. 17.5 to 50 mm Depth 25 mm 	08050 PN:TK01488 	Cutter dia. 17.5 to 50 mm Depth 50 mm 
06050 PN:TK01166 	Cutter dia. 14 to 18 mm Depth 50 mm 	08075 PN:TJ17436 	Cutter dia. 17.5 to 50 mm Depth 75 mm 
08050 PN:TK01488 	Cutter dia. 19 to 50 mm Depth 50 mm 		

Attachment and Detachment of Cutter

⚠ WARNING

- Turn the Magnet Switch OFF and unplug the power plug when replacing the Cutter.
- Do not use any combination of the Pilot Pin and Cutter not indicated in the combination compatibility table.

⚠ CAUTION

- Pay attention not to let cutting chips enter in the Cutter insertion area.
If cutting chips have entered the Cutter insertion area, remove the cutting chips completely before attaching the Cutter.

Raise the Drill Motor by turning the Rod Handles (①) in the clockwise direction.

Attachment of Cutter

- 1 Take the Pilot Pin (②) which suits the size of Cutter (③) to be used and insert the Pilot Pin (②) in the Cutter (③).

- 2 Align the depression in the Cutter (③) with the white line on the Sleeve (⑤) at the tip of the Spindle Arbor (④) and insert the Cutter (③).
When the Cutter (③) is pushed right in, the Sleeve (⑤) can be turned to the right and will lock into place with a click.

* If the Cutter (③) will not go in, turn the Sleeve (⑤) to the left and try again.

Pull down out of the body

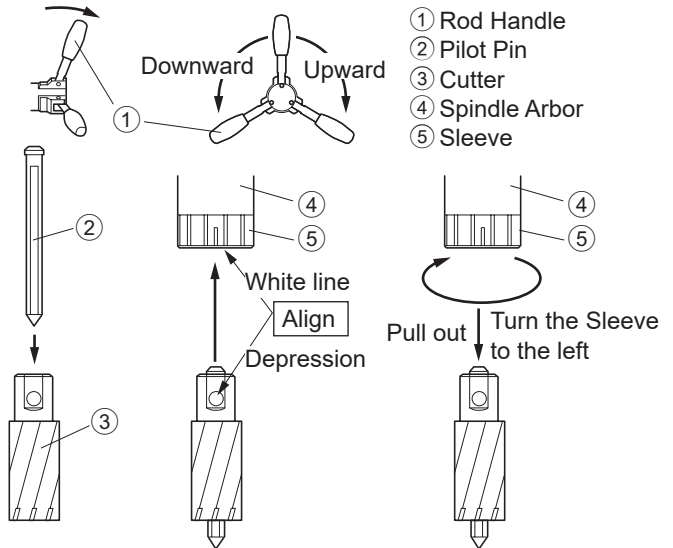

Detachment of Cutter

- 1 To remove the Cutter (③), turn the Sleeve (⑤) to the left and pull out the Cutter (③).

Preparation of Chip Breaker

Be sure to use the Chip Breaker when drilling holes with a plate thickness of 35 mm or more. If you do not use the Chip Breaker the machinability will deteriorate, the Blade will be damaged, and the service life will be shortened.

⚠ CAUTION

- When setting the Chip Breaker, see that the tip of Blade may not come into contact with the Cutter.

Use the attached Chip Breaker if the cutting chips are tangled with the Cutter or the plate thickness is thick and cutting chips are clogged. Chip Breaker shreds cutting chips generated in the drilling into small pieces and facilitates chips smooth discharging.

1 Install the Cutter.

Loosen the Hex. Socket Head Cap Screw 5×12 (④) and retract the Blade (③) in the arrow direction until it cannot be retracted any further, and then install the Cutter.

2 Fix the Blade (③).

Secure with a Hex. Socket Head Cap Screw 5×12 (④) to the Blade Base (②) so that the skimmer of the Blade (③) and Cutter is about 0.3 to 0.5 mm.

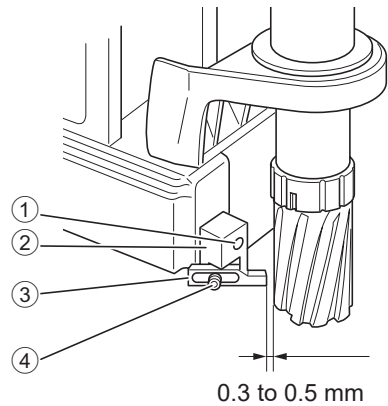

- ① Hex. Socket Head Cap Screw 6×10
- ② Blade Base
- ③ Blade
- ④ Hex. Socket Head Cap Screw 5×12

Preparation of Cutting Oil / Cutting Oil Safety Precautions

WARNING

(1) Use

- Use Cutting Oil for cutting purpose only. Do not use it for household purposes.

(2) Handling Precautions

- The Cutting Oil contains amine. Do not mix it up with rust inhibitor, etc. containing nitrite.
- Wear safety glasses for eye protection when handling Cutting Oil. Eye injury may result if Cutting Oil gets into your eyes.
- Wear protective gloves for hand protection when handling Cutting Oil. Skin injury may result if Cutting Oil comes into contact with your skin.
- Wear respirator when exposure to respiratory hazards with oil mist or vapor is anticipated. Inhalation of oil mist or vapor may make you feel sick.
- When diluting Cutting Oil, follow the instructions in the Operation Manual.
- Keep Cutting Oil out of reach of children.
- Do not drink Cutting Oil.

(3) First Aid

- If Cutting Oil gets into your eyes, immediately open your eyelids with your fingers and wash your eyes with plenty of water for at least 15 minutes. If your eyes feel irritated, consult with a medical doctor for medical instructions.
- If Cutting Oil comes into contact with your skin, immediately wash it away with plenty of water and soap. Take off contaminated clothes. Clean the clothes if you need to wear it again. If your skin feels irritated, consult with a medical doctor for medical instructions.
- If someone inhales oil mist or vapor, immediately take him/her to an area where fresh air is abundant and wrap up his/her body with a blanket, etc. to keep body temperature. Have him/her take a rest and consult with a medical doctor for medical instructions.
- If someone drinks Cutting Oil, immediately make him/her drink plenty of water and vomit it. Consult with a medical doctor for medical instructions. When unconscious, do not pour water into his/her mouth nor induce him/her to vomit.

(4) Instructions in Case of Fire

- If fire breaks out in the vicinity, wear PPE (personal protective equipment) and use foam, powder or CO₂ fire extinguisher to put the fire out from the windward.

(5) Storage

- When storing Cutting Oil after use, put into a container with a tight sealing lid to prevent contamination from dust or moisture.
- Avoid direct sunlight, rainwater or the like and store Cutting Oil in a dim cool area.

(6) Disposal

- For disposal of concentrate solution and used fluid, request a waste-disposal company to dispose them as industrial waste in accordance with the local laws and regulations.
- Treat flushing water through pH adjustment, condensation/sedimentation, activated sludge process, activated carbon adsorption, etc., and discharge it in accordance with the regulations of your local municipal bylaw.
- Residual dross will remain in an emptied container. Be careful when handling an empty container.

(7) Others

- When Cutting Oil is poured into another container for use, post chemical and label information at the site where it is kept. At the same time, keep the Operation Manual handy so that the manual can be referred to whenever necessary.
- For further details, contact us for product safety data sheet.
- All the information and descriptions that have been provided are based on the currently available documents and information, which may be revised upon our new recognition and/or discovery.
- The precautions provided apply to regular handling. If special handling method is used, take safety measures that are suitable for your applications and usage.

The information contained herein is for your reference purpose only, to which we make no warranty of any kind and for which we shall not be held responsible.

⚠ CAUTION

- When drilling large-diameter, deep holes, it is difficult for the Cutting Oil to reach the cutting edge, so make sure to use plenty of Cutting Oil.

Preparation of Cutting Oil

- 1 Use Nitto genuine blue.**
Cutting performance and life may be reduced when other Cutting Oils are used.
- 2 Dilute the Cutting Oil in the proportion of eight to ten times with tap water. Do not use well water for dilution.**
- 3 Remove Rubber Cap from Oil Tank. Fill in Oil Tank with Cutting Oil to the sideline on the Tank. Be careful not to spill on the tool.**

Oil Flow Control

The Cutting Oil flow is controlled by adjusting the P-Valve observing the Oil Dropper (①) on the side of the Drill Motor. As a guide for the oil feed rate it is generally recommended that the Slugs (chips) be kept constantly wet during the drilling and free from discoloration due to burning etc. The flow rate adjustment should be performed during the drilling or when the Pilot Pin is depressed after lowering the Drill Motor. The P-Valve should be closed when operations are interrupted for a long period of time.

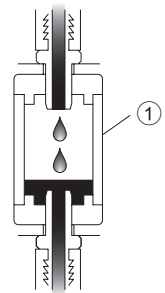

① Oil Dropper

Connecting the Power Supply Plug to Power Source

Turn the power switch OFF before plugging the power plug.

Always use appropriate voltage for the power source. Pay attention to voltage drop when using an extension cord.

6 Basic Operation

⚠ WARNING

- **Do not wear gloves.**
Wearing gloves has the risk of involving hands in rotating knives and chips.
- **Always wear eye protection.**
- **Always wear earplugs.**
- **Wear respiratory protective equipment.**
- **In case of high-altitude work, please confirm that there are no people below.**
The tool body may fall. Also, there is a possibility that Slugs will pop out after drilling. Please confirm that there are no people in the range considering the fall of the Slug.

⚠ CAUTION

- **Do not use hard material such as a screwdriver, to operate the Motor Switch.**
This may damage the panel and switch, which would lead to tool failure.

Starting and Stopping

Motor Switch will not operate and the Drill Motor will not rotate unless the Magnet Switch is turned ON.

Starting

- 1 Turn the Magnet Switch ON.**
When the Magnet Switch is turned ON, the Switch lamp will turn green and the Magnet will be activated.
- 2 Turn the Motor Switch ON.**
When the Motor Switch is turned ON, the Drill Motor will start to rotate.

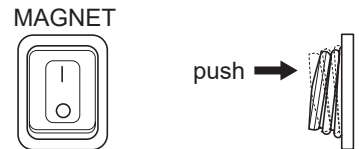

Stopping

- 1 Turn the Motor Switch OFF.**
When the Motor Switch is turned OFF, the Drill Motor will stop to rotate.
- 2 Turn the Magnet Switch OFF.**
When the Magnet Switch is turned OFF, the Switch lamp will turn OFF and the Magnet will be deactivated.

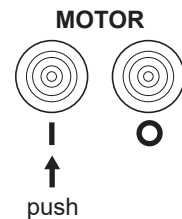

Drilling Procedure

1 Stamp a Punch Mark.

A large Punch Mark should always be stamped quite vertical to the workpiece. Be careful to get the precise position for the Punch Mark since it serves as the drilling center guide.

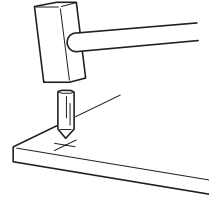

2 Align with the Punch Mark.

Turn the Rod Handle to slightly lower the Cutter and align the tip of Pilot Pin to the Punch Mark.

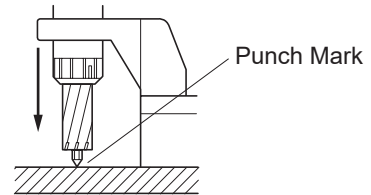

3 Turn the Magnet Switch ON.

⚠ WARNING

- There is a risk of the main unit to sway when abnormal objects such as cutting chips are caught between the attaching surface of the Magnet and the workpiece.

Make sure to keep it clean by preventing entry of abnormal objects such as cutting chips and checking that no uneven surface or rust is observed on the surface. The magnetic force will be weak when there is a gap between the attaching surface of the Magnet and the work piece.

MAGNET



push →



When the Magnet Switch is turned ON, the Switch lamp will turn green and the Magnet will be activated. Check that the Magnet is attached by the magnetic force.

4 Mount the Guard as shown in the figure.

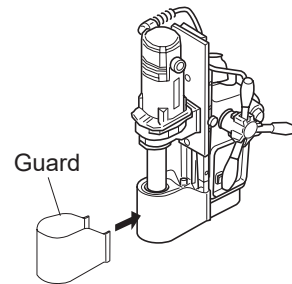

5 Adjust the flow rate of Cutting Oil.

⚠ CAUTION

- For feeding of the Cutting Oil, check the flow rate with the oil dropper before start drilling.
- Securely insert the oil tank in the oil tank bracket.

The Pilot Pin will be pushed up and the Cutting Oil will start to flow by turning the P-Valve, turning the Rod Handle and lowering the Drill Motor. Tighten the P-Valve when the work is completed.

6 Turn the Motor Switch ON.

⚠ WARNING

- Do not touch any rotating parts.

When the Motor Switch is turned ON, the Drill Motor will start to rotate.

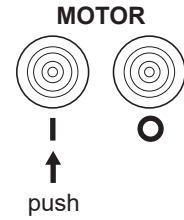

7 Start automatic feed drilling.

⚠ CAUTION

- Once it has started feeding, do not touch the Rod Handles until the drilling is finished.
- Do not use automatic feed if the finish side is slanted.

Push the Rod Handles (①) towards the body to activate the automatic feeding.

The feed in the first stage of cutting operation is automatically slow and manual feed is not required. When putting a hole through workpiece with a tapered bottom surface or bottom surface with a radius, such as angle, channel, H-section steel, etc., use manual feed at the start as well as toward the end of drilling operation where the likelihood of tool chipping high.

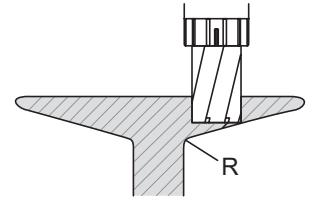
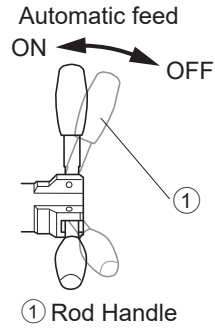

8 Finish drilling the hole.

⚠ WARNING

- Beware of ejecting Slug at the finish with the hole. Never touch the Slug with bare hands since it is hot and sharp.

When the drilling is finished, the Drill Motor will stop to rotate.

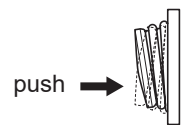

9 When it has stopped, pull the Rod Handles to outside and turn to clockwise and lift up the Drill Motor to the upper limit.

10 Quickly set the Magnet Switch to OFF.

If you fail to do this, the Magnet is kept activated and shorten its life.

11 Remove the Slug.

⚠ WARNING

- **Do not start the next drilling with a Slug remaining on the Cutter.**
The tool has automatic slug discharge system. But when the Slug would not come out by turning the feed handle to lift up the Cutter, do not try to turn the Handle forcefully. This will result in tool or Cutter damage.

Upon drilling complete, Slug (2) will be ejected automatically by the spring-operated Pilot Pin (1).

If the Slug (2) left is choked inside the Cutter (3), turn the Handle to lift up the Cutter (3) to eject the Slug (2) forcefully. When even turning the Handle with the same force as in the feed for cutting a hole, you cannot eject the Slug (2), do not turn the Handle forcefully anymore. Remove the Slug (2) from inside the Cutter (3) by tapping the Collar (5) of the Slug (2) with a Needle (4) stick or alike.

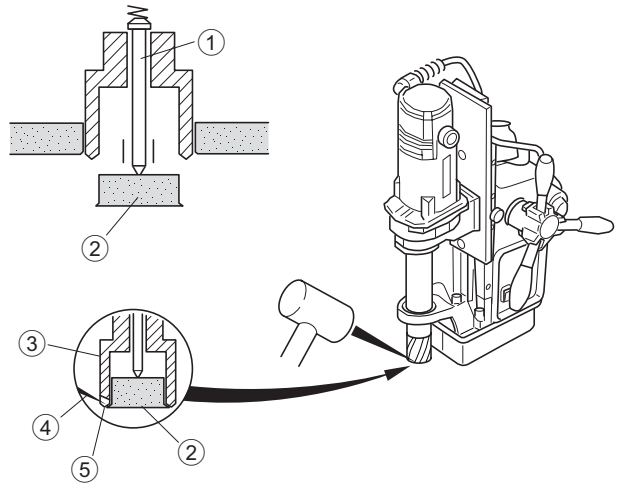

- ① Pilot Pin
- ② Slug
- ③ Cutter
- ④ Needle
- ⑤ Collar

Drilling Oblong Hole

⚠ WARNING

- Avoid drilling oblong hole with automatic feed since it may cause the Cutter to break or cause unexpected accidents.
- Always use manual feed for making oblong hole and work slowly.
- When making oblong hole, be sure to have the Pilot Pin positioned on the workpiece before cutting next holes.

- 1 Drill oblong hole in the order of ①, ②, ③.**
For the steps ② and ③, take care so that the Cutter may not be fed into the workpiece with too much force. Arrange spacing between each step of drilling operations so that the Pilot Pin will always hit the material yet to be machined.

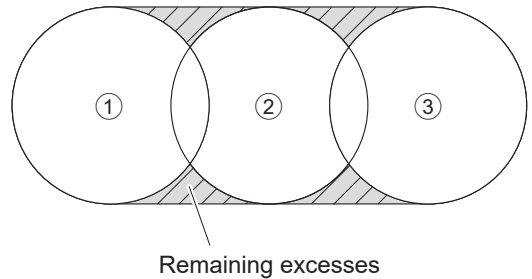

- 2 File away any remaining excesses.**

Using Manual Feed for Drilling Laminated Plates

⚠ WARNING

- Always use manual feed for drilling laminated plates and work slowly.
- Laminations must be clamped together securely.
- When drilling laminated plates, raise the Cutter after the top plate has been drilled and remove the Slug from the hole. Then drill the lower plate.
- Leaving the Slug will cause the Cutter to slide around and eventually lift the Magnet off.

7 Troubleshooting

WARNING

- Never attempt to repair tool yourself. Injury or damage to equipment may result.
- Please feel free to consult the retailer where you purchased the tool or the nearest office of Nitto Kohki Group, when the following symptoms appear or when you have any questions about our products.

The tool has electronic control. Be sure to turn OFF all the switches, raise up the Drill Motor, and then check the tool, when the operator come across to the following situations such as.

Problem	Causes	Solutions
The lamp does not light up even when Magnet Switch is turned ON.	Power line of the tool is not connected to the wall outlet securely.	Connect power line.
Drill Motor does not start even when Magnet Switch is turned ON and the lamp lights up.	Electromagnet does not have the holding power (somehow, the coil is cut off).	Replace the Magnet part.
The tool drifts away when it starts cutting.	Workpiece is too thin and does not have enough magnet holding power.	Put back-up steel plate.
	Chip or swarf is held between Magnet and workpiece.	Clean the sole of Magnet.
Drill Motor stops during the cutting operation.	The Cutter is heavily worn out or broken.	Replace with a new Cutter.
	Non-Nitto brand Cutter is used.	Replace with a Nitto Cutter.
	Chip or swarf does not come out due to deep holes (thick Plate).	Set up the Chip Breaker.
	Cutting Oil flow is poor.	Adjust to supply enough Cutting Oil.
	Non-Nitto Cutting Oil is used.	Change to Nitto Cutting Oil.
	Changed to manual feed in the middle of auto operation. *1	Start with auto feed.
	Cutting is done with manual feed.	Slow down the manual feed speed.
Drill Motor does not stop after the hole cut is finished.	Cutting is resumed towards the end of the operation.	O.K. with the tool. *2
	Cutting is done with twist drill.	Cut with manual feed.
Stopped in the middle of the cutting, and restarted but does not cut into and stop again.	Chips in the hole prevents the Cutter edge come into contact with workpiece.	Take out the chips from the hole and resume cutting.

Note: *1 The circuit detects load during manual feed, and then no-load in the next short period until the clutch is engaged for auto feed and thus it considers the cutting is finished.

*2 The cutting after reset does not give the circuit enough load signal and thus it considers still being in cutting mode and Drill Motor is kept feeding down. But do not worry as the Limit will turn OFF the Drill Motor at the bottom position.

8 Maintenance and Inspection

⚠ WARNING

- Be sure to turn the switch OFF and remove the power plug from power supply during maintenance and inspection.
- Perform periodic inspection to check for loosening of the attachment screws for each part. Retighten loose screws as required.

Keeping the Drill Motor at the Lifted-Up Position

Keep the Drill Motor at the lifted-up position while not in use, or for the purpose of safety, when you do not use the tool even for a while if it has a Cutter mounted. The Pilot Pin and/or Cutter may have the risk to be damaged if you keep the Cutter at the low position while carrying around.

Periodic Application of Grease to Sliding Surface

Apply grease periodically to the sliding surface of the main unit and the sliding board.

Adjustment of Loose Slide Board

⚠ CAUTION

- When tightening the adjustment screw to adjust the looseness of the slide board, check that the slide board is at the position of the Slide Board Adjustment Screw.

The drilling accuracy will deteriorate and the service life of the Cutter will be significantly short when looseness exists at the main unit and the slide board. When looseness is observed, adjust it by evenly tightening five Slide Board Adjustment Screws on the side of the main unit to a degree in which the tool does not go down by its weight.

Bracket Inspection

Among other things, drilling accuracy hinges on the Bracket that supports the Arbor Body. See that the Bracket mounting bolts are tight, from time to time.

Keeping the Tip of Pilot Pin Sharp

When the tip of Pilot Pin (①) gets dull, it sometimes fails to seat properly in punched hole, and results inaccurate hole position. See that the tip is sharp enough from time to time. If you find otherwise, regrind with care or replace as required. Grinding with too much force makes the tip rather dull or soften the pin material to such a degree that it is no longer usable.

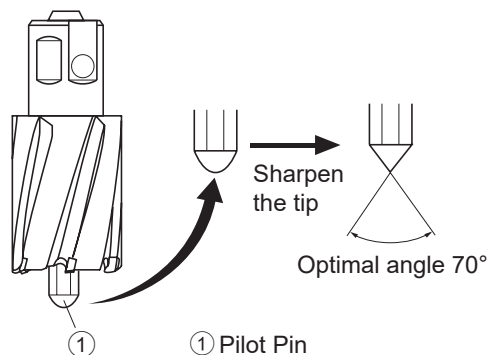

Recovery Measures When Pilot Pin Gets Jammed

To replace the Cutter, dismantle the Cutter from Arbor Body and remove the Pilot Pin from the old Cutter and insert it into the new replacement Cutter. The Pilot Pin serves as the guide for the Cutter centering. However, there are cases the pin would not come off easily because cutting chips in the clearance between the Cutter and Pilot Pin, cause jamming. In such, tap the tip of the Pilot Pin with a WOODEN hammer or alike to push it out.

Cutter Regrinding

When you need to regrind our Cutters, please contact the retailer where you purchased the tool or the nearest office of Nitto Kohki Group.

Carbon Brushes Inspection and Replacement

⚠ CAUTION

- Unplug the tool.
- Replace two carbon brushes at the same time.
- After replacing the Carbon Brush, operate the unit for about ten minutes with no load.

Check Carbon Brushes for wear periodically. When the length of Carbon Brushes gets as short as 6 mm, replace it with a new one, for, if you do not, risks are that you will have a rectification problem which may cause tool failure.

- 1 Remove the Brush Cap with a straight slot screwdriver.**
- 2 Remove the worn-out Carbon Brush and replace it with a new one. Then reattach the Brush Cap.**

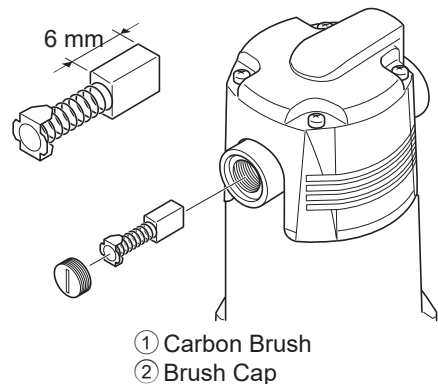

Storing the tool

Store the tool according to the following warnings and cautions.

⚠ WARNING

- When the tool is not in use, store out of the reach of children.

⚠ CAUTION

- When the tool is not in use, store in a place with low humidity.

Disposal

- Separate power tools, accessories, and packing materials for environmentally friendly recycling.
- Do not dispose of the power tool as household garbage.
- When disposing of electric tools, hand them over to Nitto Kohki or your dealer.



9 Optional Parts

NITTO KOHKI Brand Cutting Oil

⚠ CAUTION

- Use NITTO KOHKI Brand Cutting Oil for ATRA ACE.

Part No.	Part Name
TB01507	Cutting Oil 2 L (Light Blue)

Supporting Magnet Ass'y

Part No.	Part Name
TB04374	Supporting Magnet Ass'y

Sleeve 6.5 Ass'y Twist Drills

Part No.	Part Name
TB02536	Sleeve 6.5 Ass'y

- ① Sleeve 6.5 Ass'y
- ② Hex. Socket Set Screw with Cup Point 6×5

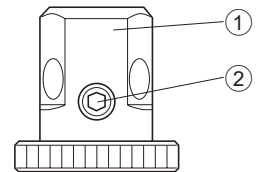

Pilot Pin

⚠ CAUTION

- Whenever you buy a Cutter, you should also buy a Pilot Pin to suit.

Part No.	Part Name	Applicable Cutter (mm)	Max. Plate Thickness (mm)
TK01167	Pilot Pin 06025	HI-BROACH 14 to 17 dia.	25
TK01486	Pilot Pin 08025	HI-BROACH 17.5 to 50 dia.	
TK01487	Pilot Pin 08035	JETBROACH 17.5 to 40 dia.	35
TK01166	Pilot Pin 06050	HI-BROACH 14 to 18 dia.	50
TK01488	Pilot Pin 08050	HI-BROACH 19 to 50 dia.	
		JETBROACH 17.5 to 55 dia.	
TJ17436	Pilot Pin 08075	JETBROACH 17.5 to 55 dia.	75

Cutter

JETBROACH One-touch Type 25 mm Depth

(metric sizes)

Part No.	Diameter × Depth	Part No.	Diameter × Depth	Part No.	Diameter × Depth	Part No.	Diameter × Depth
TK01711	17.5 × 25	TK01718	21 × 25	TK01725	24.5 × 25	TK01732	29 × 25
TK01712	18 × 25	TK01719	21.5 × 25	TK01726	25 × 25	TK01733	30 × 25
TK01713	18.5 × 25	TK01720	22 × 25	TK01727	25.5 × 25	TK01734	31 × 25
TK01714	19 × 25	TK01721	22.5 × 25	TK01728	26 × 25	TK01735	32 × 25
TK01715	19.5 × 25	TK01722	23 × 25	TK01729	26.5 × 25	TK01736	33 × 25
TK01716	20 × 25	TK01723	23.5 × 25	TK01730	27 × 25	TK01737	34 × 25
TK01717	20.5 × 25	TK01724	24 × 25	TK01731	28 × 25	TK01738	35 × 25

JETBROACH One-touch Type 35 mm Depth

(metric sizes)

Part No.	Diameter × Depth	Part No.	Diameter × Depth	Part No.	Diameter × Depth	Part No.	Diameter × Depth
TK01249	17.5 × 35	TK01258	22 × 35	TK01267	26.5 × 35	TK01276	35 × 35
TK01250	18 × 35	TK01259	22.5 × 35	TK01268	27 × 35	TK01277	36 × 35
TK01251	18.5 × 35	TK01260	23 × 35	TK01269	28 × 35	TK01278	37 × 35
TK01252	19 × 35	TK01261	23.5 × 35	TK01270	29 × 35	TK01279	38 × 35
TK01253	19.5 × 35	TK01262	24 × 35	TK01271	30 × 35	TK01280	39 × 35
TK01254	20 × 35	TK01263	24.5 × 35	TK01272	31 × 35	TK01281	40 × 35
TK01255	20.5 × 35	TK01264	25 × 35	TK01273	32 × 35		
TK01256	21 × 35	TK01265	25.5 × 35	TK01274	33 × 35		
TK01257	21.5 × 35	TK01266	26 × 35	TK01275	34 × 35		

JETBROACH One-touch Type 50 mm Depth

(metric sizes)

Part No.	Diameter × Depth	Part No.	Diameter × Depth	Part No.	Diameter × Depth	Part No.	Diameter × Depth
TK01282	17.5 × 50	TK01294	24 × 50	TK01306	33 × 50	TK01318	45 × 50
TK01283	18 × 50	TK01295	24.5 × 50	TK01307	34 × 50	TK01319	46 × 50
TK01284	19 × 50	TK01296	25 × 50	TK01308	35 × 50	TK01320	47 × 50
TK01285	19.5 × 50	TK01297	25.5 × 50	TK01309	36 × 50	TK01321	48 × 50
TK01286	20 × 50	TK01298	26 × 50	TK01310	37 × 50	TK01322	49 × 50
TK01287	20.5 × 50	TK01299	26.5 × 50	TK01311	38 × 50	TK01323	50 × 50
TK01288	21 × 50	TK01300	27 × 50	TK01312	39 × 50	TK01324	51 × 50
TK01289	21.5 × 50	TK01301	28 × 50	TK01313	40 × 50	TK01325	52 × 50
TK01290	22 × 50	TK01302	29 × 50	TK01314	41 × 50	TK01326	53 × 50
TK01291	22.5 × 50	TK01303	30 × 50	TK01315	42 × 50	TK01327	54 × 50
TK01292	23 × 50	TK01304	31 × 50	TK01316	43 × 50	TK01328	55 × 50
TK01293	23.5 × 50	TK01305	32 × 50	TK01317	44 × 50		

JETBROACH One-touch Type 75 mm Depth

(metric sizes)

Part No.	Diameter × Depth	Part No.	Diameter × Depth	Part No.	Diameter × Depth	Part No.	Diameter × Depth
TK01350	17.5 × 75	TK01361	26.5 × 75	TK01372	37 × 75	TK01383	48 × 75
TK01351	18 × 75	TK01362	27 × 75	TK01373	38 × 75	TK01384	49 × 75
TK01352	19 × 75	TK01363	28 × 75	TK01374	39 × 75	TK01385	50 × 75
TK01353	20 × 75	TK01364	29 × 75	TK01375	40 × 75	TK01386	51 × 75
TK01354	21 × 75	TK01365	30 × 75	TK01376	41 × 75	TK01387	52 × 75
TK01355	22 × 75	TK01366	31 × 75	TK01377	42 × 75	TK01388	53 × 75
TK01356	23 × 75	TK01367	32 × 75	TK01378	43 × 75	TK01389	54 × 75
TK01357	24 × 75	TK01368	33 × 75	TK01379	44 × 75	TK01390	55 × 75
TK01358	24.5 × 75	TK01369	34 × 75	TK01380	45 × 75		
TK01359	25 × 75	TK01370	35 × 75	TK01381	46 × 75		
TK01360	26 × 75	TK01371	36 × 75	TK01382	47 × 75		

HI-BROACH One-touch Type 25 mm Depth**(metric sizes)**

Part No.	Diameter × Depth	Part No.	Diameter × Depth	Part No.	Diameter × Depth	Part No.	Diameter × Depth
TK00700	14 × 25	TK01398	22 × 25	TK01410	30 × 25	TK01421	41 × 25
TK00701	15 × 25	TK01399	22.5 × 25	TK01411	31 × 25	TK01422	42 × 25
TK00702	16 × 25	TK01400	23 × 25	TK01412	32 × 25	TK01423	43 × 25
TK00703	17 × 25	TK01401	23.5 × 25	TK01413	33 × 25	TK01424	44 × 25
TK01391	17.5 × 25	TK01402	24 × 25	TK01414	34 × 25	TK01425	45 × 25
TK01392	18 × 25	TK01403	24.5 × 25	TK01415	35 × 25	TK01426	46 × 25
TK01393	19 × 25	TK01404	25 × 25	TK01416	36 × 25	TK01427	47 × 25
TK01394	19.5 × 25	TK01405	26 × 25	TK01417	37 × 25	TK01428	48 × 25
TK01395	20 × 25	TK01407	27 × 25	TK01418	38 × 25	TK01429	49 × 25
TK01396	21 × 25	TK01408	28 × 25	TK01419	39 × 25	TK01430	50 × 25
TK01397	21.5 × 25	TK01409	29 × 25	TK01420	40 × 25		

HI-BROACH One-touch Type 50 mm Depth**(metric sizes)**

Part No.	Diameter × Depth	Part No.	Diameter × Depth	Part No.	Diameter × Depth	Part No.	Diameter × Depth
TK00723	14 × 50	TK00733	24 × 50	TK00743	34 × 50	TK00753	44 × 50
TK00724	15 × 50	TK00734	25 × 50	TK00744	35 × 50	TK00754	45 × 50
TK00725	16 × 50	TK00735	26 × 50	TK00745	36 × 50	TK00755	46 × 50
TK00726	17 × 50	TK00736	27 × 50	TK00746	37 × 50	TK00756	47 × 50
TK00727	18 × 50	TK00737	28 × 50	TK00747	38 × 50	TK00757	48 × 50
TK00728	19 × 50	TK00738	29 × 50	TK00748	39 × 50	TK00758	49 × 50
TK00729	20 × 50	TK00739	30 × 50	TK00749	40 × 50	TK00759	50 × 50
TK00730	21 × 50	TK00740	31 × 50	TK00750	41 × 50		
TK00731	22 × 50	TK00741	32 × 50	TK00751	42 × 50		
TK00732	23 × 50	TK00742	33 × 50	TK00752	43 × 50		

10 Ordering Parts

For replacement of parts and components, contact the retailer where you purchased the tool or the nearest office of Nitto Kohki Group.

In ordering parts and components give each part number, part name and quantity required.

Use only NITTO genuine parts.

11 Exploded View/Parts List

WA-5500 Exploded View/Parts List

⚠ CAUTION

- Users should never perform disassembly of the tool.

This illustration is for reference only.

For repair or replacement of the tool, request service from the retailer where you purchased the tool or the nearest office of Nitto Kohki Group.

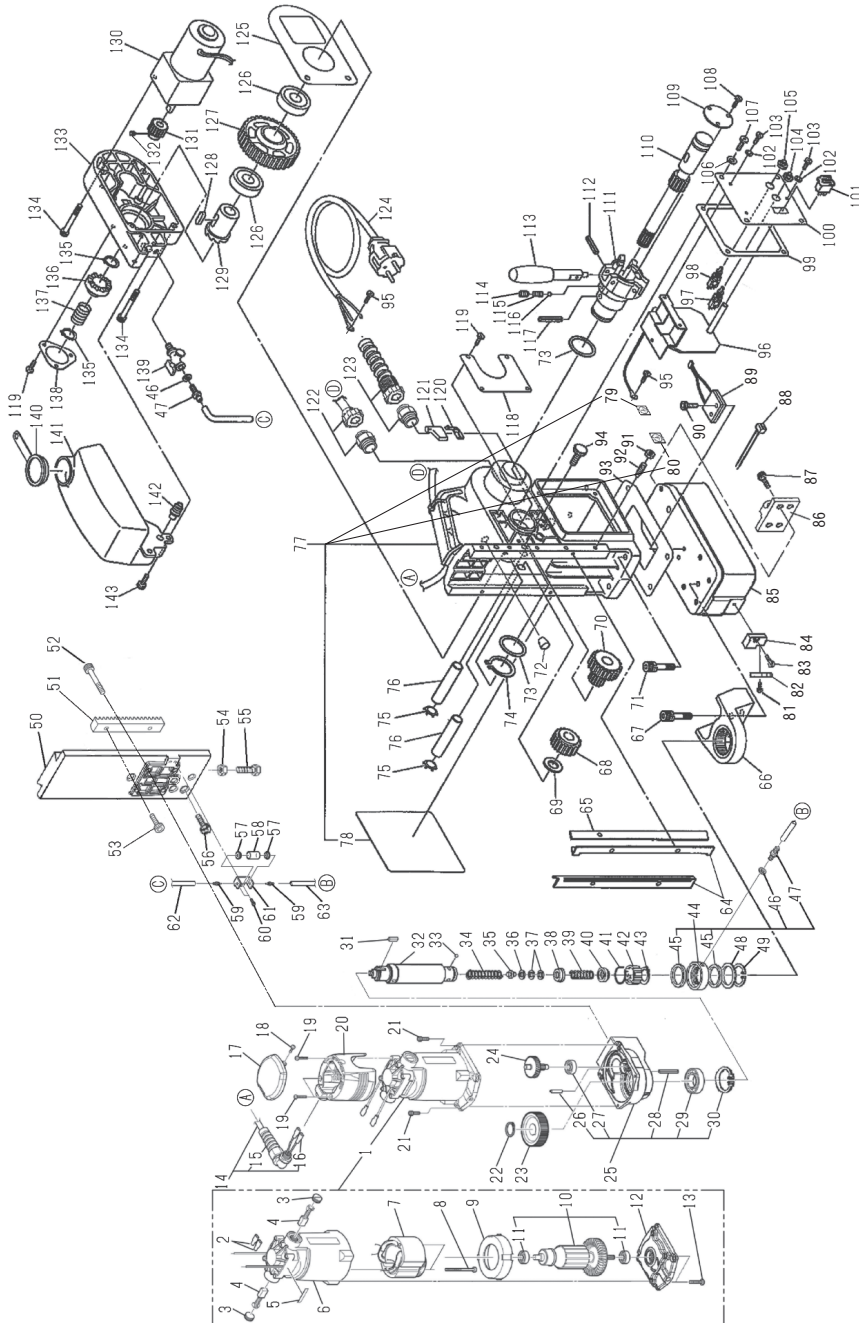

Parts inside () are components of the above assembly.

No.	Part No.	Part Name	Qty
1	TB10497	Drill Motor Assy	1 set
2	(TQ12299)	Male Terminal TMEDN630809-MA	2
3	(TQ11581)	Brush Cap	2
4	(TB08186)	Carbon Brush Assy	1 set
5	(TQ11585)	Label Voltage 230V	1
6	(TB07723)	Motor Case Assy	1 set
7	(TQ11583)	Stator 230V	1
8	(TQ11584)	Pan Head Tapping Screw 5x60	2
9	(TQ11582)	Fan Case	1
10	(TB07724)	Armature Assy 230V	1 set
11	(TQ11925)	Ball Bearing 608LLB	2
12	(TB10263)	Motor Flange Assy	1 set
13	(TQ11337)	Pan Head Tapping Screw 5x25	4
14	TB10265	Connecting Cable Assy A	1 set
15	(TQ06824)	Cord Protector	1
16	(TQ11503)	Female Terminal TMEDN630820-FA	2
17	TQ13797	Motor Head Cover B	1
18	TP14489	Pan Head Tapping Screw 4x10	1
19	TQ13101	Pan Head Tapping Screw 4x25	4
20	TQ13796	Motor Head Cover A	1
21	TP01945	Hex. Socket Head Cap Screw 5x12	4
22	CQ02200	External Retaining Ring C-25	1
23	TQ15119	Spur Gear 0.8x83	1 set
24	TB10264	Gear Shaft Assy	1 set
25	TB10222	Gear Box Sub Assy	1 set
26	(TQ12425)	Knock-pin MS5-15	1
27	(TP12419)	Ball Bearing 628ZZ	1
28	(TP03261)	Spring Pin 4x26 AW	1
29	(TQ15116)	Ball Bearing 6005LLU	1
30	(CP20569)	Internal Retaining Ring C-47	1
31	TQ15120	Parallel Key 6x6x20	1
32	TQ15117	Spindle Arbor	1
33	TB01672	Ball 5/16 Assy	1 set
34	TQ10649	Spring 1.4x16.2x149	1
35	TQ01895	Pilot Spacer	1
36	TP15848	Spacer 10.5x19x5	1
37	TP13905	Internal Retaining Ring RTW-19	2
38	TB01348	Washer Assy	1 set
39	TQ01898	Spring 0.8x12x31	1
40	TB01349	Push Ring Assy	1 set
41	TQ01896	Rotating Spring	1
42	TQ01897	Sleeve	1
43	TP15239	External Retaining Ring C-28	1
44	TB00713	Oil Ring Assy	1 set
45	(TP14499)	Oil Seal GD38x48x4	2
46	(CP21947)	Packing S-4.7x8x0.8	2
47	(TP14500)	Hose Nipple	2
48	TP12773	Washer 38.5x54x1	1
49	TP14969	External Retaining Ring ISTW-38	1
50	TQ15927	Slide Board	1
51	TQ02496	Rack	1
52	TP04532	Hex. Socket Head Cap Screw 5x30	4
53	TP14178	Hex. Socket Head Cap Screw 6x10	2

No.	Part No.	Part Name	Qty
54	TP08584	Hex. Nut M8	1
55	TP04857	Hex. Bolt 8x25	1
56	TP14174	Hex. Socket Head Cap Screw 10x25	1
57	TQ00671	Dropper Packing	2
58	TQ00670	Dropper Pipe	1
59	TQ00672	Dropper Nipple	2
60	TP06342	Hex. Socket Head Cap Screw 4x10	2
61	TQ13696	Dropper Holder	1
62	TB01098	Tube 4x7x3000 Assy (250mm)	1 set
63	TB01098	Tube 4x7x3000 Assy (120mm)	1 set
64	TP12777	Slide Plate	2
65	TQ06773	Gib	1
66	TB05407	Bracket Assy	1 set
67	TQ03346	Hex. Socket Head Cap Screw 8x30 with Spring Washer	3
68	TQ11730	Spur Gear 1.5x26	1
69	TQ06779	Washer 12.2x28x1	1
70	TQ11729	Spur Gear 1.5x14x29	1
71	TQ03345	Hex. Socket Head Cap Screw 8x25 with Spring Washer	4
72	TQ10791	Rubber Stopper	1
73	TQ06780	Washer 32.2x42x2	2
74	TQ06781	External Retaining Ring ISTW-32	1
75	TQ04715	Internal Retaining Ring CRTW-12	2
76	TQ06776	Shaft	2
77	TB10852	Body Sub Assy	1 set
78	(TQ12858)	Label Warning	1
79	(TQ11282)	Label Earth	1
80	(TQ16412)	Label Functional Grounding	1
81	TP01945	Hex. Socket Head Cap Screw 5x12	1
82	TQ10787	Blade	1
83	TP14178	Hex. Socket Head Cap Screw 6x10	1
84	TQ10695	Blade Base	1
85	TB07185	Square Pole Assy (220V-240V)	1 set
86	TP17985	Chain Guide	1
87	TP01644	Hex. Socket Head Cap Screw 6x12	4
88	TB00573	D Cord Assy	1 set
89	TQ01363	Side Slip Detection Function Assy	1 set
90	TQ10600	Hex. Socket Head Cap Screw 4x18	2
91	TP07419	Hex. Nut Type3 M6	5
92	TQ00730	Hex. Socket Set Screw with Dog Point 6x20	5
93	TQ06794	Packing Pole	1
94	TQ02931	Set Screw	1
95	LQ00190	Pan Head Screw 4x8	2
96	TB10871	Control Board Assy (220V-240V)	1 set
97	TB07055	Switch SW3 Assy	1 set
98	TB07054	Switch SW2 Assy	1 set
99	TQ06787	Packing Body	1
100	TQ15928	Switch Plate	1
101	TQ07306	Rocker Switch	1
102	TQ00258	Seal Washer M4	3
103	TQ01526	Pan Head Screw 4x10	3
104	TQ10085	Waterproofing Cap Black	1
105	TQ10467	Waterproofing Cap Red	1
106	TQ01331	Seal Washer M6	4

No.	Part No.	Part Name	Qty
107	TP02419	Pan Head Screw 6x10	4
108	TP08598	Pan Head Screw 3x5	3
109	TQ06762	Plate Automatic Feeder	1
110	TQ06760	Gear Shaft	1
111	TQ06761	Handle Stem	1
112	TP12821	Spring Pin 5x26 AW Double	3
113	TQ00680	Rod Handle	3
114	TP06397	Hex. Socket Set Screw with Cup Point 6x8	3
115	TP06396	Spring	3
116	CP01123	Ball 3/16	3
117	TQ06759	Spring Pin 8x40 AW	3
118	TQ15929	Plate Spec. (220V-240V)	1
119	TP12819	Pan Head Screw 4x6	7
120	TQ07308	Terminal #250 42232-3	2
121	TQ07309	Sleeve 170891-1	2
122	TQ07097	Cable Connector 3217	1
123	TQ11075	Cable Connector 3247	1
124	TB05896	Cable Cord Assy	1 set
125	TQ06782	Packing Gear Box	1
126	TQ06786	Ball Bearing 6906ZZ	2
128	TQ06764	Spur Gear 1x88	1
128	TQ06765	Parallel Key Both Ends Round 8x7x20	1
129	TQ06783	Clutch B	1
130	TQ06767	Geared Motor	1
131	TQ06768	Spur Gear 1x23	1
132	CP26427	Hex. Socket Set Screw with Cup Point 5x6	1
133	TQ06769	Gear Box	1
134	TQ06770	Hex. Socket Head Cap Screw 4x35	8
135	TP06387	External Retaining Ring GV-16	2
136	TP12325	Clutch A	1
137	TP06374	Spring	1
138	TQ06777	Cover Plate	1
139	TP14495	P-Valve PT1/8	1
140	TQ06785	Rubber Cap	1
141	TQ06784	Oil Tank	1
142	TQ06786	Rubber Plug	1
143	TP04715	Hex. Socket Head Cap Screw 4x8	3

ACCESSORIES

No.	Part No.	Part Name	Qty
—	TP04696	Hex. Socket Screw Key 3	1
—	TP01939	Hex. Socket Screw Key 4	1
—	TP17014	Spanner 8x10	1
—	TJ16019	Pilot Pin 08050	1
—	TQ01051	Pin 8x10	1
—	TQ12007	Guard	1
—	TQ15933	Instruction Manual	1
—	TA99027	Chain Assy	1 set
—	—	Cutting Oil 0.5L Assy	1 set
—	TB10866	Carrying Case Assy	1 set

