

# ***INSTRUCTION MANUAL***

## **ELECTRIC CHAMFERING TOOL**

Please read this manual carefully before you attempt to use your tool so that you may use it properly and safely.

## **CIRCUIT BEVELER Model ECB-0203** **PROFESSIONAL TOOL**



### **Specifications**

Model		ECB-0203	
Power Source (Single Phase)		230 V ~	
Rated Power Consumption		450 W	
Rated Time		30 minute	
Rated Speed (No Load)		10,000 min <sup>-1</sup>	
Chamfering Capacity	Stainless Steel	0 - 1.5C, 2R	
	Mild Steel	0 - 3C, 2R, 3R	
Chamfer Angle		45°	
Mass (Weight)		2.5 kg	
Sound Pressure Level	No Load	83 dB(A)	
	Load	87 dB(A)	
Sound Power Level	No Load	96 dB(A)	
	Load	100 dB(A)	
Vibration Level	No Load	Motor	2.5 m/s <sup>2</sup>
		Knob	2.9 m/s <sup>2</sup>
	Load	Motor	5.1 m/s <sup>2</sup>
		Knob	4.4 m/s <sup>2</sup>

Due to continuous product development/improvement the specifications and configurations in this document are subject to change without prior notice.



Manufactured by :

**NITTO KOHKI Co., Ltd.**

2-9-4, Nakaikegami, Ohta-ku,  
Tokyo, 146-8555, Japan

Tel : (81)-3-3755-1111

Fax : (81)-3-3753-8791

E-mail : overseas@nitto-kohki.co.jp

URL : www.nitto-kohki.co.jp

**Keep the manual handy – so you can use it whenever necessary.**

Original Instructions

Thank you very much for your purchase of this **Nitto Kohki products**.

Before using your tool, please read this manual carefully so that you may use it properly to get the most out of it.

**Please keep the manual handy - so you can use it whenever necessary.**

- **English** : Please ask your dealer or distributor for instruction manual in local language(s).
- **German** : Bitte fragen Sie Ihren Händler nach eine Betriebsanleitung in Landessprache.
- **French** : S'il vous plait, veuillez demandez à votre fournisseur de manuel instruction en langue locale.
- **Spanish** : Por favor, contacte con su distribuidor para el manual de instrucciones en español.
- **Portuguese** : Por favor pessa ao seu agente ou distribuidor o manual de instruções em linguagem local.
- **Italian** : Per Manuale Istruzioni in lingua locale Vi preghiamo di rivolgerci al rivenditore o distributore.
- **Dutch** : Vraag uw handelaar om een nederladstalige gebruiksaanwijzing.
- **Swedish** : Be er lokala Åtreförsäljare eller distributör om manualer på svenska.
- **Danish** : Venligst henvend Dem til den danske distributør for instructions manualer.
- **Polish** : Proszę pytać swojego dealera lub dystrybutora o instrukcje obsługi w języku lokalnym.
- **中文** : 請向當地供應商或經銷商詢問中文使用說明書

<b>CONTENTS</b>	<b>page</b>
IMPORTANT SAFETY INSTRUCTIONS .....	2
GENERAL: TOOLS .....	2
GENERAL: POWER TOOLS .....	3
INSTRUCTIONS FOR THIS TOOL .....	4
1. USAGE .....	4
2. CHECK THE CONTENTS OF THE PACKAGE .....	4
3. PREPARATIONS .....	5
4. HOW TO OPERATE THE TOOL .....	5
5. HOW TO REPLACE INDEXABLE INSERT AND GUIDE SLEEVE .....	6
6. MAINTENANCE AND INSPECTION .....	7
7. CONDITION FOR USE .....	7
8. ORDERING SERVICE PARTS .....	7
9. OPTIONAL PARTS .....	8
10. EXPLODED DIAGRAM : ECB-0203 .....	9

### PICTOGRAM



Warning: It might be dangerous to operate the tool if the instructions supplied are not followed.



Using this tool improperly could result in serious injury. Read the instruction manual before using.



Always wear suitable eye protection.



Always wear suitable hearing protection.



Always wear respiratory protective equipment (PPE).



Always wear protective gloves for protection of hands from Vibration and Shock.

Storage Temperature	: -10°C – 60°C (no freezing)
Storage Humidity	: Maximum 90% at 25°C (no dewing)
Operating Temperature	: 5°C – 40°C
Operating Humidity	: Maximum 90% at 25°C (no dewing)
Altitude	: 1000m Max.
Over-voltage Category	: Category II according to IEC60664-1
Pollution Degree	: Degree 3 according to IEC60664-1

The following Safety notations are used throughout the manual to highlight safety precautions for the user and for the tool.



#### **WARNING:**

Indicates a potentially hazardous situation which, if not avoided by following the instructions given, could result in death or serious injury.



#### **CAUTION:**

Indicates a potentially hazardous situation which, if not avoided by following the instructions given, could result in injury or material damage.

Please note, however, that failure to observe safety precautions under the “**Caution**” category could result in a serious occurrence depending on the situation: please observe all safety precautions in the manual.

**Caution:** Important precautions for tool setup, operation and maintenance.

# IMPORTANT SAFETY INSTRUCTIONS

When using the tool, please observe the safety precautions below to prevent possible accident or injury.

## GENERAL: TOOLS

### WARNING

#### TO OPERATORS

- **Wear proper clothing for the type of work being done.**  
Take care so that clothing, ties, hair etc. will not become entangled with the moving parts. If items become entangled it will cause the operator to be pulled towards the tool and lead to possible cause of accident or injury.
- **Always wear suitable eye protection.**  
Remember, regular glasses are not safety glasses. The lenses are only shock resistant, which will not give you sufficient eye protection you may need in your working environment.
- **Always wear suitable hearing protection.**
- **Wear respiratory protective equipment (PPE).**  
Wear respiratory protective equipment (PPE) when working in an environment where dust particles are generated in operation.
- **Avoid working posture that is too stressful.**  
Always ensure a firm footing and well balanced posture.
- **Do not operate the tool if you are too tired.**
- **Never touch any moving parts of the tool when running.**

#### ABOUT WORK AREA

- **Keep the work area clean.**  
Cluttered work areas (e.g. workbench) invite accidents.
- **Carefully select the work area.**  
Do not expose tool to rain.  
Do not use tool in a wet or soaked area.  
See that the work area is adequately illuminated.
- **Never work near inflammable liquid or in a potentially explosive atmosphere.**
- **Keep children away from the work area.**  
Keep children and unauthorized people away from the work area to avoid accident or injury.

#### BEFORE OPERATION

- **Inspect tool before use.**  
Before using, check that screws are securely tightened, that any protective cover or guard is securely in place, other parts are free from damage and that the tool runs as it should.  
Check that moving parts are properly adjusted for positioning and tightened, that parts are free from damage and properly mounted, and that all other parts are in good condition for normal operation.  
Should you find any damage to the protective cover or other part, replace it in accordance with the Operation Manual. If there are no instructions in the Manual, please contact the sales agent through which you have purchased your tool or an authorized dealer near you for repair.  
Likewise, if a switch failure occurs, contact sales agent through which you have purchased your tool or an authorized dealer near you for repair.  
Do not use the tool if it does not start or stop with the start/stop switch.
- **Securely mount cutter**  
An improperly mounted cutter may fly out, causing possible damage to the tool or injury to the operator.
- **Always remove spanner, wrench, etc., once adjustment has been made with them.**
- **Use a tool appropriate for the application.**  
Avoid heavy-duty application that is beyond the capacity of tool.
- **Do not use the tool for purposes other than what it is designed for.**
- **Do not abuse tool.**  
Use tool in accordance with the specifications: you'll get the most out of it while ensuring safety.
- **Securely fasten workpiece in place.**  
Use a vice or clamp to securely fasten the workpiece in place. It is much safer this way than holding it in your hand, allowing you to operate the tool with both hands.

#### ABOUT HANDLING

- **How to store tool.**  
When the tool is not used, store it in a dry area and out of reach of children.
- **How to carry tool.**  
Do not touch the start switch while the tool is being carried.
- **Do not leave the tool unattended while it is running.**  
Turn off the start switch and disconnect the tool from power source. Do not leave the work area until the tool comes to a complete stop.

## MAINTENANCE/SERVICE

- **Do not take apart or modify tool.**

Disassembly or modification carried out without the supervision of a qualified or authorized service engineer could result in an accident or injury.

- **Inspect cutting tool and accessories, etc.**

Always check to see that cutting tool and accessories, etc. are in good operating condition without damage or deterioration before you mount them on the tool. Should you find any damage to an accessory or part, please contact sales agent through which you have purchased your tool or an authorized dealer near you for repair.

- **Check parts for damage.**

When you have found damage to accessory or other part, carefully check the damaged part to determine the extent of influence it has upon the functions of the tool - that is, determine whether it can still perform its normal functions.

Check to see that the linkage of the moving parts is OK, that all parts are OK without damage, that they are properly mounted, and that the tool functions normally. Should you find any damage to an accessory or part that may hamper proper functioning of the tool, please contact sales agent through which you have purchased your tool or an authorized dealer near you for repair.

- **Have your tool repaired at an authorized Nitto Service Center.**

For repair or parts replacement, please contact the sales agent through which you have purchased your tool or an authorized dealer near you.

- **Use only Nitto genuine parts.**

Use of improper parts may result in serious accident. To obtain a Nitto genuine part, consult this Manual or contact the sales agent from which you have purchased your tool directly.

- **Do not detach label or nameplate from tool.**

When a label/nameplate gets damaged, worn or becomes missing, contact the sales agent through which you have purchased your tool or Nitto Kohki Co. Ltd, directly for a replacement.

## DISPOSAL

- When a tool is taken permanently out of service, it is advised that the tool is disassembled, degreased and parts separated by material and recycled locally in the appropriate manner.

## GENERAL: POWER TOOLS

### WARNING

- **Always use power source per specifications on the nameplate.**
- **Never connect the earthing conductor to a gas Pipe: if you do so explosion may result.**
- **Check to see that there is no abnormality in earth- clipping or earthing conductor.**

Conduct continuity check between the earth clip and a metal portion of the machine with a tester or insulation resistance tester, if you have one. Wiring connections involving the installation of earth bar or plate into the ground will call for the expertise of a qualified electrician. Please contact your local electrical contractor.
- **Don't abuse cord.**

Don't carry tool with a cord in your hands; don't pull a cord to disconnect it from the socket. Don't give damage to cord by abusive use, such as, reworking, forced bending, exposure to heat, pulling, twisting, bundling, application of weight, pinching, hanging from metal hardware, etc.
- **Before using the tool, ensure that ground-fault circuit interrupter for electrical shock guard is installed in the power source to which the tool will be connected, as required by the Ordinance on Labor Safety and Hygiene and/or the Technical Standard for Electrical Installation.**
- **Avoid abrupt, unintentional start.**

Before connecting a power supply plug to power source, make sure that the switch is turned off.
- **Turn off the switch and disconnect the power supply plug from power source before setting up for operation or getting down to inspection or maintenance work.**
- **Do not replace the supply cord.**

When replacing the supply cord, please contact the sales agent through which you have purchased your tool or an authorized dealer near you.

# INSTRUCTIONS FOR THIS TOOL

## About Your Tool

### WARNING

- Use of power is limited to the power source specified by the rating plate.
- Operate under the power source the voltage fluctuating rate of which is within  $\pm 10\%$  of the rated voltage, and the frequency of which is 50/60Hz of sinusoidal wave.

- Before using the tool, make sure the power source to which it will be connected is fitted with an earth leakage breaker to prevent electric shock.

- Extension cord should be selected after ensuring the diameter is compatible with the length of the extension.

Beware of extremely long power cord (particularly wound up thin cords) as they may cause drops in voltage which weaken the magnetism, adversely affecting the performance and function of the unit. Do not share the extension cord with any other electric machine tools.

Extension Cord	
Max. Length	Nominal cross-sectional area
10 m	1.25 mm <sup>2</sup> or more
15 m	2.00 mm <sup>2</sup> or more
30 m	3.50 mm <sup>2</sup> or more

- When performing maintenance, inspection, replacement or adjustment of parts, make sure to disconnect the attachment plug from the receptacle.

- To replace the Indexable Insert after using, do not touch with bare hands as the Indexable Insert and holder are heated at high temperature.

- Protect your body from cutting chips.

The heated chips can be spread out when cutting. Wear the safety goggle, working gloves, and long sleeve working cloths and safety shoes to protect your body. Also keep away your face.

- Use our original Indexable Inserts.

- Do not use the worn or damaged Indexable Insert.

- The service life of Indexable Insert can be shortened depending on the surface finishing conditions of the stainless plate.

(e.g. : The life of Indexable Insert for No.2B finishing material is about half of the BA finishing material.)

- For machining the thin plate, if non-chamfered portion is below than 1.5 mm, the plate can be placed between the Indexable Insert and the guide sleeve, thereby the chamfering amount can be greatly varied. Adjust the chamfering amount so that the non-chamfered portion can be surely larger than 1.5 mm. (Fig.1)

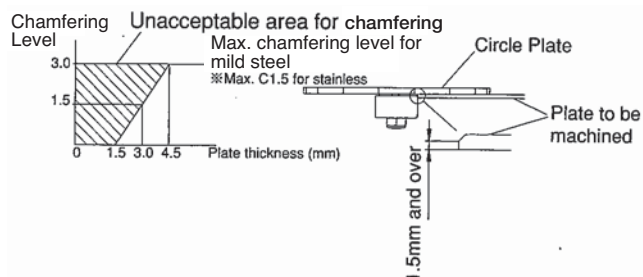
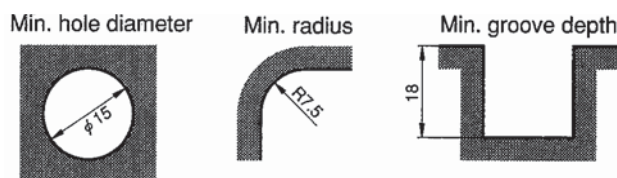

Fig.1

- Size of material which can be chamfered.



The value minimum hole diameter and minimum radius are obtainable when the O.D. 22 guide sleeve is replaced with the accessory Ball Bearing 687ZZ.

Fig.2

## 1. USAGE

This tool is for chamfering workpieces with a Indexable Insert.

## 2. CHECK THE CONTENTS OF THE PACKAGE

Check the contents and make sure that the tool does not have any damage which may have occurred during transportation. The contents should correspond to the list as follows. In case of damage/missing parts, please contact the sales agent from whom you purchased the tool.

Package Contents	Qty	check
CIRCUIT BEVELER ECB-0203	1set	
Sub-handle	1	
Grip guard	1	
Indexable Insert with hole 12.7	1	
Indexable Insert Set Screw 4 x 7	1	
Hex. Socket Screw Key 5	1	
Spanner T-15D	1	
Spanner 8 x 10	1	
Ball Bearing 687ZZ	1	
Gauge C3	1	
Instruction Manual	1	
Declaration of Conformity	1	
Caution for Use	1	

### 3. PREPARATIONS

#### ⚠ WARNING

- Be Sure to turn the switch OFF and remove the power plug from power supply whenever setting up the tool.

Mount the attached sub-handle on the bearing case through the Grip Guard. (Fig.3)

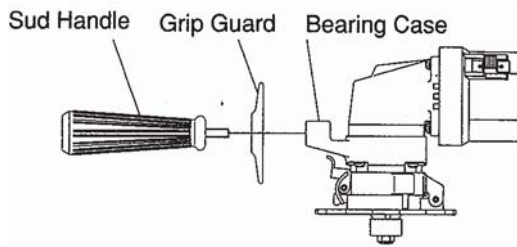

Fig. 3

### 4. HOW TO OPERATE THE TOOL

#### ⚠ WARNING

- During work, always wear safety goggles. If the workplace generates a lot of dust, use a dust mask.

#### 4-1. Start and Stop

#### ⚠ CAUTION

- Always be sure the unit is in the OFF position before plugging the power cord into an outlet.

As shown in Fig.4, placing the switch in the ON position (indicated by the arrow) initiates operation. Turn the switch to the OFF side (indicated by the arrow) to stop operation. (Fig.4)

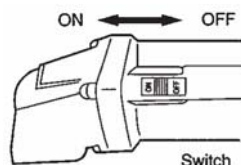

Fig.4

#### 4-2. How to Adjust Chamfering Levels

#### ⚠ WARNING

- Be sure to turn the switch OFF and remove the power plug from power supply whenever adjusting chamfering levels.

- The max. chamfering capacity

Stainless Steel: 1.5C, R2

Mild Steel: 3C, R3

Note that the optional R3 Indexable Insert is

needed for machining the R3, and the optional O.D.24 mm Guide Sleeve and R2 Indexable Insert are required for machining the R2.

- (1) Use the accessory Hex. Socket Screw Key 5 to loosen the Hex. Socket Head Cap Screw mounted on the adjust ring.
- (2) Fit the accessory gauge to the circle plate and guide sleeve, then turn the circle plate so that the Indexable Insert edge may touch the gauge and move up/down to adjust the chamfering amount.
- (3) After the chamfering amount adjusted, securely fasten the Hex. Socket Head Cap Screw.

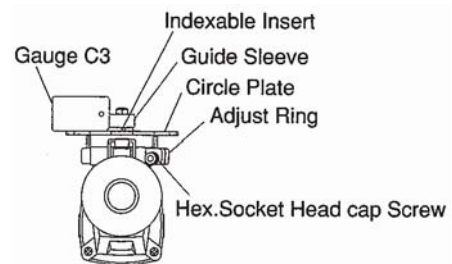

Fig. 5

#### 4-3. Before Cutting

- (1) When you start to work from the corner as shown in Fig.6, cut off the corner first with grinder etc., then start.
- (2) Before start chamfering, make sure that the Switch is set on and the Indexable Insert is rotating. Then, apply the tool to the workpieces. The Indexable Inserts may be damaged if the Switch is set on after Indexable Inserts are pressed on the workpieces or they may also be damaged if they are pressed to the workpieces abruptly.
- (3) The workpieces should be fixed as much as possible while working.

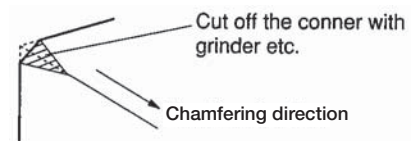

Fig. 6

#### 4-4. Feeding Speed

Be sure you should avoid quick feeding or heavy shock. Please refer to Table.1.

Stainless Steel	4cm/sec
Mild Steel	3cm/sec

Table. 1

#### 4-5. How To Operation

### WARNING

- Be sure to turn the switch OFF and remove the power plug from power supply whenever adjusting chamfering angle.
- The workpieces should be fixed as much as possible while working.

- (1) Select the chamfering level.
- (2) Make sure that the Switch is set at "OFF" position and connect the power plug to the power supply.
- (3) Hold the Housing up. Start the tool.
- (4) Hold the Housing and Sub Handle firmly. Place the circle plate on the top of part to be machined, then slowly fit the Indexable Insert to the point to be machined. Feed in the Indexable Insert turning direction while tracing the side face using the Guide Sleeve.



Fig. 7

In case of chamfering stainless steel, chamfer deep to the desired chamfering level by one span of operation. Repeat of chamfering makes the life of Indexable Insert shorter.

### 5. HOW TO REPLACE INDEXABLE INSERT AND GUIDE SLEEVE

### WARNING

- Always turn the Switch OFF and remove the power plug from the power supply.
- Bear in mind that Indexable Insert and holder are much heated right after the operation.

#### 5-1. How To Replace Indexable Insert

- (1) Pull out the lever in the arrow direction to remove the Lock Wire from the stopper, and the Circle Plate will swing. (Fig.8)

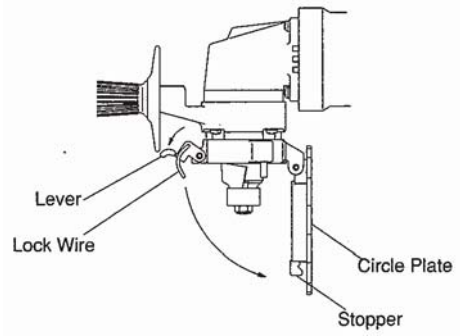

Fig. 8

- (2) Use the accessory Hex. Socket Screw key 5 to fix the holder. (Fig.9)

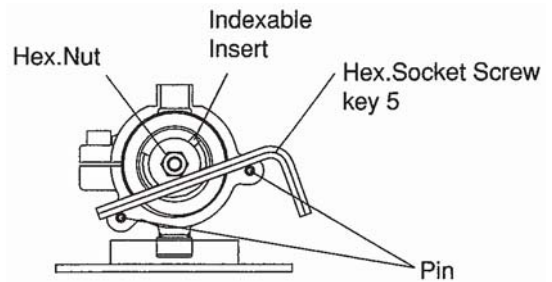

Fig. 9

- (3) Use the accessory Spanner T-15D to loosen the Indexable Insert holding screw, and remove the Indexable Insert. (Fig.10)

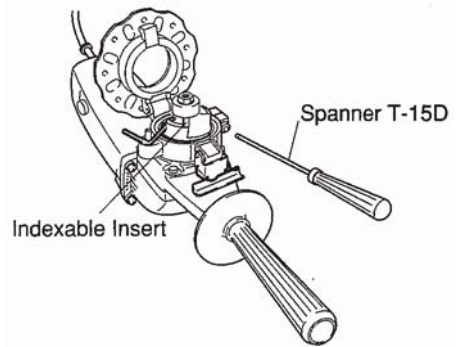

Fig. 10

- (4) Set the new Indexable Insert (including the one whose face is changed) while using care on the Indexable Insert direction, and use the Spanner T-15D to securely fasten the Indexable Insert holding screw.
- (5) Swing the Circle Plate, hang the Lock Wire on the Stopper groove, and use the lever to lock it. (Fig.11)

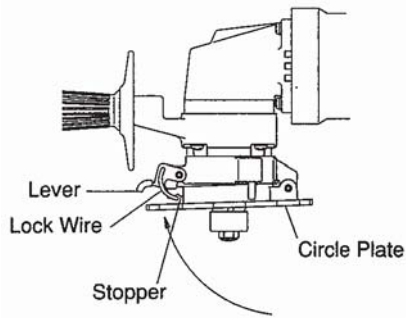

Fig. 11

### 5-2. How To Replace Guide Sleeve

If the O.D.22mm Guide Sleeve was replaced with the accessory Ball Bearing, the two points can be used with the one face of Indexable Insert. It is only limited for the mild steel machining. The Indexable Insert life may be extremely shortened through machining the stainless steel. Also if it has been replaced with the accessory O.D.24mm Guide Sleeve, you can machine the R2.

- (1) Use the accessory Hex. Socket Screw key 5 to fix the holder rotation. (Fig.9)
- (2) Use the accessory Spanner 8 x 10 to loosen the nut, and remove the O.D.22mm Guide Sleeve. (Fig.12)

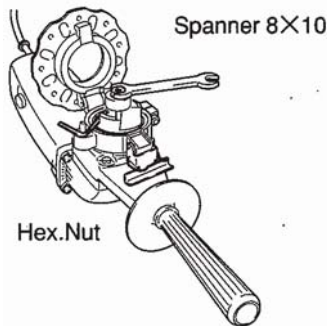

Fig. 12

- (3) Mount the Ball Bearing or the O.D.24mm Guide Sleeve and securely fasten the Hex. Nut. (Fig.13)

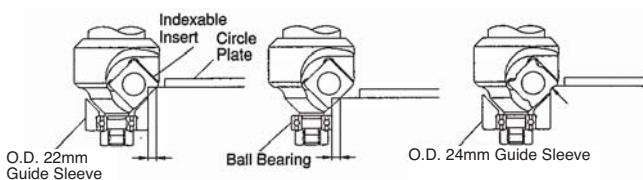

Fig. 13

## 6. MAINTENANCE AND INSPECTION

### ! WARNING

- Be sure to turn the switch OFF and remove the power plug from power supply during maintenance and inspection.
- Perform periodic inspection to check for loosening of the attachment screws for each part. Retighten loose screws as required.

#### 6-1. Replacing the Carbon Brushes

- After replacing the carbon brushes, always run the unit for at least 10 minutes under no load conditions.

Periodically check the for wear on Carbon Brush. If the remaining length of Carbon Brush is 6 mm around, the resulted poor commutation may cause a machine failure. Remove the Brush Cap and renew in such a case.

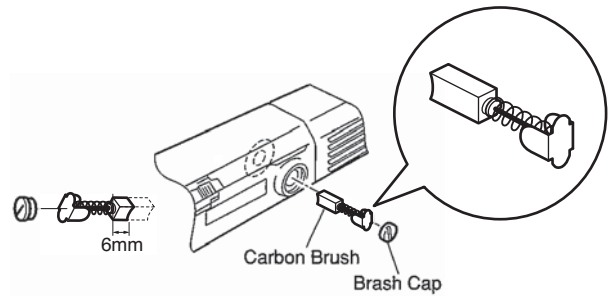

Fig. 14

## 7. CONDITION FOR USE

Burn-out chips suggest that either the feed speed is too slow or the Indexable Insert has worn-out. Change the cutting conditions or check the conditions of the Indexable Insert.

## 8. ORDERING SERVICE PARTS

For further operational and handling information or for replacement of parts and components, contact the company from whom you purchased the tool or an authorized dealer.

In ordering parts and components give each part number, part name and quantity required. Use only NITTO genuine parts.



## 9. OPTIONAL PARTS

Part No.	Description	Qty
TB01159	Indexable Insert with Hole 12.7	10 pcs
TB01791	Indexable Insert 12.7 sq. R2	10 pcs
TB01651	Indexable Insert 12.7 sq. R3	10 pcs
TB02857	O.D.24mm Guide Sleeve	1 set
TB02862	Dust Box ※	1 set
TB03097	Plate for Linear Purpose	1 set

※ The Dust Box should be mounted on the plate for linear purpose when using.

### 9-1. How To Operate The Plate for Linear Purpose

The Plate for Linear Purpose is used for much more stable linear machining.

Use the Hex. Socket Screw Key 4 (attached on the plate Ass'y for linear purpose) to fix the Hex. Socket Head Cap Screw of 2 pieces on the Circle Plate. In this case arrange the position relation between the Guide Sleeve (or Ball Bearing) and the Plate for Linear Purpose so that they are positioned on the same straight line as shown on the Fig.15. Since the position relation between the Plate for Linear Purpose, Sub Handle and motor may vary depending on the chamfering amount, select the appropriate easy-to-operate position when mounting them.

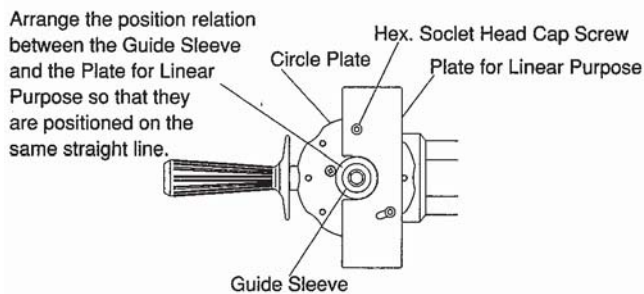

Fig. 15

### 9-2. How To Operate The Dust Box

- The dust box Should be mounted on the Plate for Linear Purpose, but cannot be mounted directly on the Circle Plate.

Use the Hex. Socket Screw Key 4 to fasten the two pieces of Hex. Socket Head Cap Screw on the Plate for Linear Purpose. Clear away the cutting chips accumulated in the Dust Box as far as possible. (Fig.16)

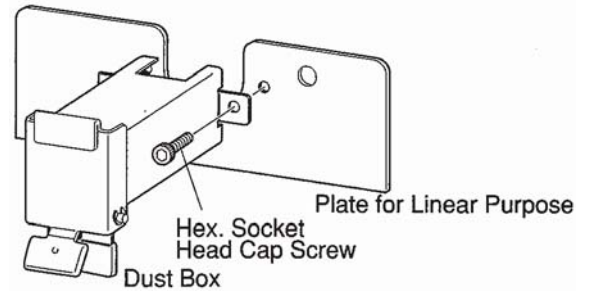
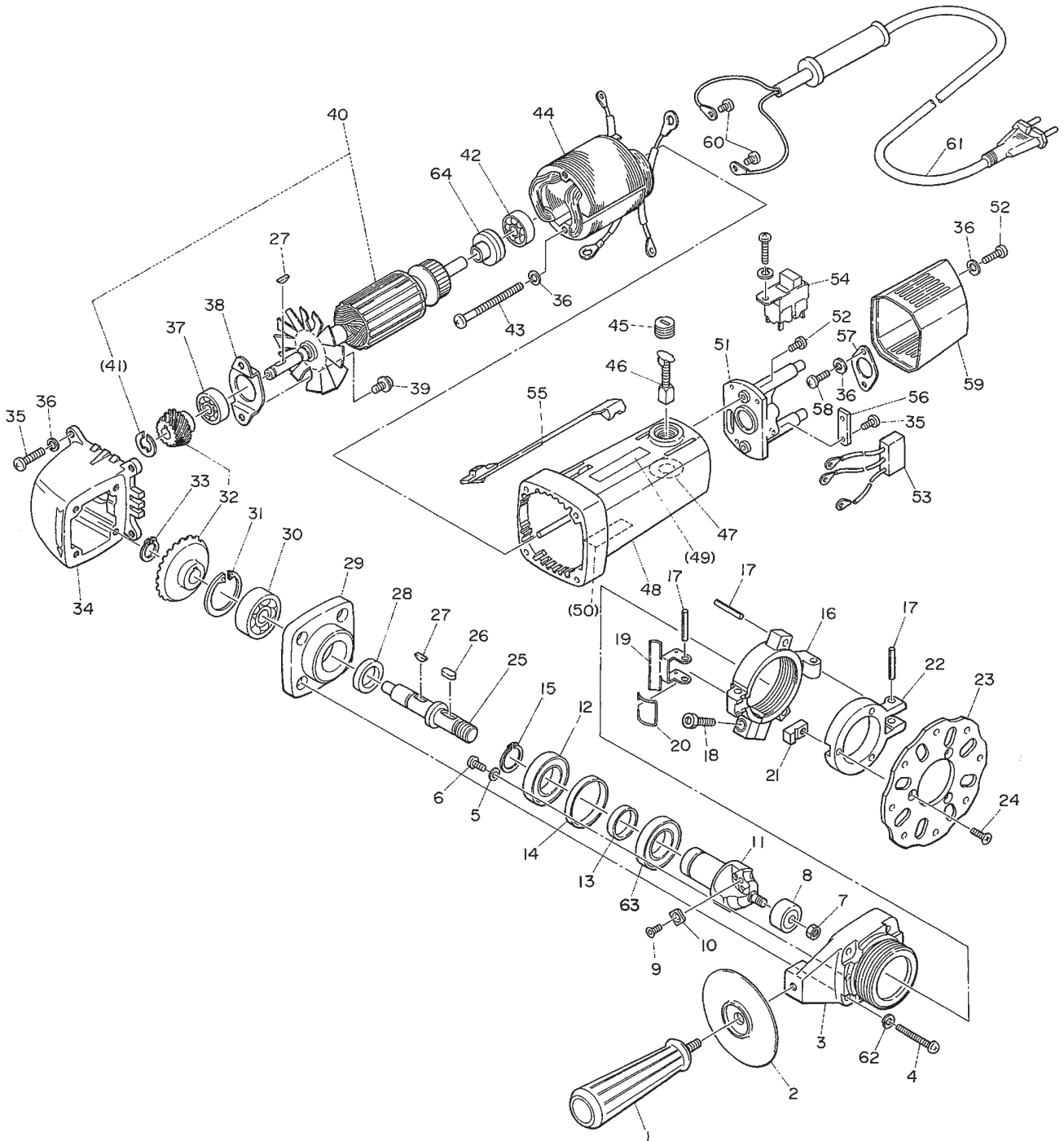

Fig. 16

## 10. EXPLODED DIAGRAM : ECB-0203

### WARNING

This diagram is for your reference only. Do not attempt to service or repair the Tool. Do not take the Tool apart. Contact an authorized Nitto dealer for all service and repair of the Tool. Improper service and repair can cause accidents and service injuries. Never attempt to modify the Tool. Never attempt service or repair the Tool yourself.



The part numbers with ( ) are included in the Ass'y parts written above them.

No.	Part No.	Description	Qty	Price
1	TA91354	Sub Handle Ass'y	1 set	
2	TP16126	Grip Guard	1	
3	TQ03648	Bearing Case	1	
4	TP15163	Pan Head Screw 4 x 35	4	
5	TP00144	Washer M4	3	
6	TP02797	Pan Head Screw 4 x 6	3	
7	TP01924	Hex. Nut M6	1	
8	TB02856	Guide Sleeve O.D.22mm Ass'y	1 set	
9	TQ01629	Indexable Insert Set Screw 4 x 7	1	
10	TB01159	Indexable Insert with Hole 12.7 (10pcs. / set)	1 set	
11	TQ03649	Holder	1	
12	TP06385	Ball Bearing 6904ZZ	1	
13	TQ03650	Spacer 20.1 x 25 x 5	1	
14	TQ03651	Spacer 31.1 x 36.9 x 5	1	
15	CP03040	External Retaining Ring C-20	1	
16	TQ03655	Adjust Ring	1	
17	TP08389	Spring Pin 4 x 24	4	
18	TP07118	Hex. Socket Head Cap Screw 6 x 16	1	
19	TQ03658	Lever	1	
20	TQ03659	Lock Wire	1	
21	TQ03660	Stopper	1	
22	TQ03656	Swing Ring	1	
23	TQ03657	Circle Plate	1	
24	TP02750	Countersunk Head Screw 4 x 12	3	
25	TQ00827	Spindle	1	
26	TQ01370	Parallel Key both ends round 4 x 4 x 18	1	
27	TP03755	Woodruff Key 2.5 x 10	2	
28	TP16195	Dust Seal	1	
29	TP16119	Bearing Case	1	
30	TP03675	Ball Bearing 6200ZZ	1	
31	TP01173	Internal Retaining Ring C-30	1	
32	TB01097	Pinion Gear Ass'y	1 set	
33	TP04595	External Retaining Ring C-10	1	
34	TB00609	Gear Case Sub Ass'y	1 set	
35	TP16208	Pan Head Tapping Screw 4 x 16	6	
36	TP04234	Spring Washer M4	10	
37	TP11779	Ball Bearing 629DD	1	
38	TP16252	Bearing Supporter	1	

No.	Part No.	Description	Qty	Price
39	TP11245	Pan Head Screw 4 x 10	2	
40	TB08645	Rotor Sub Ass'y A	1 set	
41	(TQ00422)	Bowed Retaining Ring E BETW-6	1	
42	TP16251	Ball Bearing 627ZZ	1	
43	TP16254	Pan Head Screw 4 x 60	2	
44	TA9A444	Stator Ass'y	1 set	
45	TP16213	Brush Cap	2	
46	TA9A633	Carbon Brush Ass'y	1 set	
47	TP16266	Insulation Seat Metal	2	
48	TB08697	Motor Case Ass'y	1 set	
49	(TQ12767)	Label Warning CE Mark	1	
50	(TP16216)	Plate Nitto	1	
51	TP16256	Insulation Stand	1	
52	LP12832	Pan Head Tapping Screw 4 x 14	4	
53	TQ03965	Capacitor SKT	1	
54	TA99917	Switch Ass'y	1 set	
55	TA99916	Switch Lever Ass'y	1 set	
56	TP16261	Cord Clamp	1	
57	TP16262	Cord Stopper	1	
58	TP04235	Pan Head Screw 4 x 8	2	
59	TP16255	Motor Cover	1	
60	TP16292	Pan Head Screw 3.5 x 8	4	
61	TB02514	Electric Cord Ass'y	1 set	
62	TP04075	Spring Washer M4	4	
63	TQ11013	Ball Bearing 6904 LLB	1	
64	TQ12590	Insulation Board	1	

#### ACCESSORIES

No.	Part No.	Description	Qty	Price
	TP04004	Hex. Socket Screw Key 5	1	
	TQ03654	Ball Bearing 687ZZ	1	
	TP17014	Spanner 8 x 10	1	
	TQ01683	Spanner T-15D	1	
	TQ01629	Indexable Insert Set Screw 4 x 7	1	
		Indexable Insert with Hole 12.7 Ass'y	1	
	TQ03961	Gauge C3	1	
	TQ12768	Instruction Manual	1	
	TQ12769	Declaration of Conformity	1	



## ■ Overseas Affiliates / Offices

### NITTO KOHKI U.S.A., Inc.

4525 Turnberry Drive, Hanover Park, IL 60133, U.S.A

Tel: (1)-630-924-9323 Fax: (1)-630-924-0303  
<http://www.nittokohki.com/index.html>

### NITTO KOHKI EUROPE Co., Ltd.

Unit 21, Empire Centre, Imperial Way,  
Watford Hertfordshire, WD24 4TS, United Kingdom

Tel: (44)-01923-239668 Fax: (44)-01923-248815  
<http://www.nitto.co.uk/>

### NITTO KOHKI DEUTSCHLAND GmbH

Lerchenstr. 47, D-71144 Steinenbronn, Germany

Tel: (49)-7157-22436 Fax: (49)-7157-22437  
<http://www.nitto-kohki.de/>

### NITTO KOHKI AUSTRALIA Pty. Ltd.

77 Brandl Street, Eight Mile Plains QLD 4113,  
Australia

Tel: (61)-7-3340-4600 Fax: (61)-7-3340-4640  
<http://www.nitto-australia.com.au/>

### NITTO KOHKI Co., Ltd. Singapore Branch

10 Ubi Crescent #01-62, Ubi Techpark Lobby D,  
Singapore 408564

Tel: (65)-6227-5360 Fax: (65)-6227-0192  
<http://www.nitto-kohki.co.jp/e/nksb/>

### NITTO KOHKI Co., Ltd. Shanghai Representative Office

#1117 Ruijing Building, Maoming South Road,  
Shanghai 200020 China

Tel: (86)-21-6415-3935 Fax: (86)-21-6472-6957  
<http://www.nitto-kohki.cn/>

### NITTO KOHKI Co., Ltd. Shenzhen Representative Office

#0726 International Culture Building, 3039, Shennan  
Zhong Rd., Futian District, Shenzhen, 518003 China

Tel: (86)-755-8375-2185 Fax: (86)-755-8375-2187  
<http://www.nitto-kohki.cn/>

### NITTO KOHKI Co., Ltd. Bangkok Representative Office

38Q, House Convent Bldg, 7th Floor, Unit 7A,  
Convent Rd, Silom, Bangkok, 10500 Thailand

Tel: (66)-2-632-0307 Fax: (66)-2-632-0308  
[http://www.nittobkk.com/eng\\_index.htm](http://www.nittobkk.com/eng_index.htm)

## EC DECLARATION OF CONFORMITY

We hereby declare that the following our product conforms with the essential health and safety requirements of  
EEC Directives.

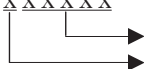
Product: ELECTRIC CHAMFERING TOOL  
Model: CIRCUIT BEVELER: ECB-0203  
Serial No: XXXXXX  
  
Manufacturer: NITTO KOHKI Co., Ltd.  
2-9-4, Nakaikegami, Ohta-ku, Tokyo, 146-8555, Japan  
Authorised Compiler in the Community:  
Masatoshi Ogue  
President  
NITTO KOHKI EUROPE Co., Ltd.  
Unit21, Empire Centre, Imperial Way, Watford Hertfordshire, WD24 4TS, UK  
Tel:(44)-01923-239668 Fax:(44)-01923-248815  
Directive : 98/37/EC and 2006/42/EC Machinery Directive  
2006/95/EC Low Voltage Directive  
2004/108/EC EMC Directive

The above product has been evaluated for conformity with above directives using the following European standards.  
The technical construction file (TCF) for this product is retained at the above manufacturer's location.

Machinery Directive: EN ISO12100-1:2003, EN ISO12100-2:2003,  
EN ISO14121-1:2007, EN60745-1:2006, others

Name: K.Kishi

Title: GENERAL MANAGER MACHINE TOOLS DIV.

Being the responsible person appointed and employed the manufacturer.