

INSTRUCTION MANUAL

ELECTRIC CHAMFERING TOOL

Please read this manual carefully before you attempt to use your tool so that you may use it properly and safely.

MINI BEVELER Model EMB-0307B

PROFESSIONAL TOOL



Specifications

Model		EMB-0307B	
Power Source (Single Phase)		230V ~ 50/60Hz	
Rated Power Consumption		1100W	
Rated Time		Continue	
Rated Speed (No Load)		11,000min ⁻¹	
Chamfering Capacity	Stainless Steel	0C - 3C, 2R, 3R, 4R	
	Mild Steel	0C - 7C, 2R, 3R, 4R	
Chamfering Angle		15°- 45°	
Mass (Weight)		3.9 kg	
Sound Pressure Level	No Load	84 dB(A)	
	Load	95 dB(A)	
Sound Power Level	No Load	97 dB(A)	
	Load	108 dB(A)	
Vibration Level	No Load	Motor	3.8 m/s ²
		Knob	1.6 m/s ²
	Load	Motor	10.1 m/s ²
		knob	4.9 m/s ²

Due to continuous product development/improvement the specifications and configurations in this document are subject to change without prior notice.



Manufactured by :

NITTO KOHKI Co., Ltd.

2-9-4, Nakaikagami, Ohta-ku,
Tokyo, 146-8555, Japan

TEL : (81)-3-3755-1111

FAX : (81)-3-3753-8791

E-mail : overseas@nitto-kohki.co.jp

URL : www.nitto-kohki.co.jp

Keep the manual handy – so you can use it whenever necessary.

Original Instructions

Thank you very much for your purchase of this **Nitto Kohki product**.

Before using your tool, please read this manual carefully so that you may use it properly to get the most out of it.

Please keep the manual handy - so you can use it whenever necessary.

- **English** : Please ask your dealer or distributor for instruction manual in local language(s).
- **German** : Bitte fragen Sie Ihren Händler nach eine Betriebsanleitung in Landessprache.
- **French** : S'il vous plait, veuillez demandez á votre fournisseur de manuel instruction en langue locale.
- **Spanish** : Por favor, contacte con su distribuidor para el manual de instrucciones en español.
- **Portuguese** : Por favor pessa ao seo agente ou distribuidor o manual de instrucces ih linguagen local.
- **Italian** : Per Manuale Istruzioni in lingua locale Vi preghiamo di rivolgervi al rivenditore o distributore.
- **Dutch** : Vraag uw handelaar om een nederladstalige gebruiksaanwijzing.
- **Swedish** : Be er lokala Åtreförsäljare eller distributör om manualer pá svenska.
- **Danish** : Venligst henvend Dem til den danske distributør for instructions manualer.
- **Polish** : Prosze pytac swojego dealera lub dystrybutora o instrukcje obsługi w jezyku localnym.
- **中文** : 請向當地供應商或經銷商詢問中文使用說明書

CONTENTS	page
IMPORTANT SAFETY INSTRUCTIONS	2
GENERAL: TOOLS	2
GENERAL: POWER TOOLS	3
INSTRUCTIONS FOR THIS TOOL	4
1. USAGE	4
2. CHECK THE CONTENTS OF THE PACKAGE	4
3. NAME OF PARTS	4
4. PREPARATIONS	4
5. HOW TO OPERATE THE TOOL	5
6. HOW TO REPLACE INDEXABLE INSERT	8
7. MAINTENANCE AND INSPECTION	8
8. CONDITION FOR USE	9
9. ORDERING SERVICE PARTS	9
10. OPTIONAL PARTS	9
11. EXPLODED DIAGRAM : EMB-0307B	10

PICTOGRAM



Warning: It might be dangerous to operate the tool if the instructions supplied are not followed.



Using this tool improperly could result in serious injury. Read the instruction manual before use.



Always wear suitable eye protection.



Always wear suitable hearing protection.



Always wear respiratory protective equipment (PPE).



Always wear protective gloves for protection of hands from vibration, Shock and Burns.

Storage Temperature	: -10°C - 60°C (no freezing)
Storage Humidity	: Maximum 90% at 25°C (no dewing)
Operating Temperature	: 5°C - 40°C
Operating Humidity	: Maximum 90% at 25°C (no dewing)
Altitude	: 1000m Max.
Over-voltage Category	: Category II according to IEC60664-1
Pollution Degree	: Degree 3 according to IEC60664-1

The following Safety notations are used throughout the manual to highlight safety precautions for the user and for the tool.



Warning:

Indicates a potentially hazardous situation which, if not avoided by following the instructions given, could result in death or serious injury.



Caution:

Indicates a potentially hazardous situation which, if not avoided by following the instructions given, could result in injury or material damage.

Please note, however, that failure to observe safety precautions under the “**Caution**” category could result in a serious occurrence depending on the situation: please observe all safety precautions in the manual.

Caution: Important precautions for tool setup, operation and maintenance.

IMPORTANT SAFETY INSTRUCTIONS

When using the tool, please observe the safety precautions below to prevent possible accident or injury.

GENERAL: TOOLS

Warning

TO OPERATORS

- **Wear proper clothing for the type of work being done.**

Take care so that clothing, ties, hair, etc. will not become entangled with the moving parts. If items become entangled it will cause the operator to be pulled towards the tool and lead to possible cause of accident or injury.

- **Always wear suitable eye protection.**
Remember, regular glasses are not safety glasses. The lenses are only shock resistant, which will not give you sufficient eye protection you may need in your working environment.
- **Always wear suitable hearing protection.**
- **Wear respiratory protective equipment (PPE).**
Wear respiratory protective equipment (PPE) when working in an environment where dust particles are generated in operation.
- **Always wear protective gloves for protection of hands from vibration, shock and burns.**
- **Avoid working posture that is too stressful.**
Always ensure a firm footing and well balanced posture.
- **Do not operate the tool if you are too tired.**
- **Never touch any moving parts of the tool when running.**

ABOUT WORK AREA

- **Keep the work area clean.**
Cluttered work areas (e.g. workbench) invite accidents.
- **Carefully select the work area.**
Do not expose tool to rain.
Do not use tool in a wet or soaked area.
See that the work area is adequately illuminated.
- **Never work near inflammable liquid or in a potentially explosive atmosphere.**
- **Keep children away from the work area.**
Keep children and unauthorized people away from the work area to avoid accident or injury.

BEFORE OPERATION

- **Inspect tool before use.**
Before using, check that screws are securely tightened, that any protective cover or guard is securely in place, other parts are free from damage and that the tool runs as it should.
Check that moving parts are properly adjusted for positioning and tightened, that parts are free from damage and properly mounted, and that all other parts are in good condition for normal operation.
Should you find any damage to the protective cover or other part, replace it in accordance with the Operation Manual. If there are no instructions in the Manual, please contact the sales agent through which you have purchased your tool or an authorized dealer near you for repair.
Likewise, if a switch failure occurs, contact sales agent through which you have purchased your tool or an authorized dealer near you for repair.
Do not use the tool if it does not start or stop with the start/stop switch.
 - **Securely mount cutter.**
An improperly mounted cutter may fly out, causing possible damage to the tool or injury to the operator.
 - **Always remove spanner, wrench, etc., once adjustment has been made with them.**
 - **Use a tool appropriate for the application.**
Avoid heavy-duty application that is beyond the capacity of tool.
 - **Do not use the tool for purposes other than what it is designed for.**
 - **Do not abuse tool.**
Use tool in accordance with the specifications: you'll get the most out of it while ensuring safety.
 - **Securely fasten workpiece in place.**
Use a vice or clamp to securely fasten the workpiece in place. It is much safer this way than holding it in your hand, allowing you to operate the tool with both hands.
- #### ABOUT HANDLING
- **How to store tool.**
When the tool is not used, store it in a dry area and out of reach of children.
 - **How to carry tool.**
Do not touch the start switch while the tool is being carried.
 - **Do not leave the tool unattended while it is running.**
Turn off the start switch and disconnect the tool from power source. Do not leave the work area until the tool comes to a complete stop.

MAINTENANCE/SERVICE

- **Do not take apart or modify tool.**

Disassembly or modification carried out without the supervision of a qualified or authorized service engineer could result in an accident or injury.

- **Inspect cutting tool and accessories, etc.**

Always check to see that cutting tool and accessories, etc. are in good operating condition without damage or deterioration before you mount them on the tool. Should you find any damage to an accessory or part, please contact sales agent through which you have purchased your tool or an authorized dealer near you for repair.

- **Check parts for damage.**

When you have found damage to accessory or other part, carefully check the damaged part to determine the extent of influence it has upon the functions of the tool – that is, determine whether it can still perform its normal functions.

Check to see that the linkage of the moving parts is OK, that all parts are OK without damage, that they are properly mounted, and that the tool functions normally. Should you find any damage to an accessory or part that may hamper proper functioning of the tool, please contact sales agent through which you have purchased your tool or an authorized dealer near you for repair.

- **Have your tool repaired at an authorized Nitto Service Center.**

For repair or parts replacement, please contact the sales agent through which you have purchased your tool or an authorized dealer near you.

- **Use only Nitto genuine parts.**

Use of improper parts may result in serious accident. To obtain a Nitto genuine part, consult this Manual or contact the sales agent from which you have purchased your tool directly.

- **Do not detach label or nameplate from tool.**

When a label/nameplate gets damaged, worn or becomes missing, contact the sales agent through which you have purchased your tool or Nitto Kohki Co. Ltd, directly for a replacement.

DISPOSAL

- When a tool is taken permanently out of service, it is advised that the tool is disassembled, degreased and parts separated by material and recycled locally in the appropriate manner.

GENERAL: POWER TOOLS

WARNING

- **Always use power source per specifications on the nameplate.**
- **Never connect the earthing conductor to a gas Pipe: if you do so explosion may result.**
- **Check to see that there is no abnormality in earth-clipping or earthing conductor.**

Conduct continuity check between the earth clip and a metal portion of the machine with a tester or insulation resistance tester, if you have one. Wiring connections involving the installation of earth bar or plate into the ground will call for the expertise of a qualified electrician. Please contact your local electrical contractor.
- **Don't abuse cord.**

Don't carry tool with a cord in your hands; don't pull a cord to disconnect it from the socket. Don't give damage to cord by abusive use, such as, reworking, forced bending, exposure to heat, pulling, twisting, bundling, application of weight, pinching, hanging from metal hardware, etc.
- **Before using the tool, ensure that ground-fault circuit interrupter for electrical shock guard is installed in the power source to which the tool will be connected, as required by the Ordinance on Labor Safety and Hygiene and/or the Technical Standard for Electrical Installation.**
- **Avoid abrupt, unintentional start.**

Before connecting a power supply plug to power source, make sure that the switch is turned off.
- **Turn off the switch and disconnect the power supply plug from power source before setting up for operation or getting down to inspection or maintenance work.**
- **Do not replace the supply cord.**

When replacing the supply cord, please contact the sales agent through which you have purchased your tool or an authorized dealer near you.

INSTRUCTIONS FOR THIS TOOL

About Your Tool

WARNING

- Use of power is limited to the power source specified by the rating plate.
- Operate under the power source the voltage fluctuating rate of which is within $\pm 10\%$ of the rated voltage, and the frequency of which is 50/60Hz of sinusoidal wave.
- Before using the tool, make sure the power source to which it will be connected is fitted with an earth leakage breaker to prevent electric shock.
- Extension cord should be selected after ensuring the diameter is compatible with the length of the extension.

Beware of extremely long power cord (particularly wound up thin cords) as they may cause drops in voltage which weaken the magnetism, adversely affecting the performance and function of the unit. Do not share the extension cord with any other electric machine tools.

Extension Cord	
Max. Length	Nominal cross-sectional area
10 m	1.25 mm ² or more
15 m	2.00 mm ² or more
30 m	3.50 mm ² or more

- When performing maintenance, inspection, replacement or adjustment of parts, make sure to disconnect the attachment plug from the receptacle.
- To replace the Indexable Insert after using, do not touch with bare hands as the Indexable Insert and holder are heated at high temperature.
- Use our original Indexable Inserts.
- Do not use the worn or damaged Indexable Insert.
- If the unit is exposed under sub-zero temperature for a prolonged period of time, it may take some time to start up. This does not mean that the unit is broken. Once the unit has warmed up, it can be used again.

1. USAGE

This tool is for chamfering workpieces with a Indexable Insert.

2. CHECK THE CONTENTS OF THE PACKAGE

Check the contents and make sure that the tool does not have any damage which may have occurred during transportation. The contents should correspond to the list as follows. In case of damage/missing parts, please contact the sales agent from whom you purchased the tool.

Package Contents	Qty	Check
MINI BEVELER EMB-0307B	1 set	
Dust Box Ass'y	1 set	
Pan Head Screw 5 × 10	3	
Carbon Brush Ass'y	1 set	
Hex. Socket Screw Key 4	1	
Indexable Insert with hole 12.7	1	
Indexable Insert Set Screw 4 × 7	1	
Hex. Nut M8	2	
Hex. Socket Set Screw 8 × 25 Special	2	
Spanner T-15D	1	
Instruction Manual	1	
Declaration of Conformity	1	

3. NAME OF PARTS

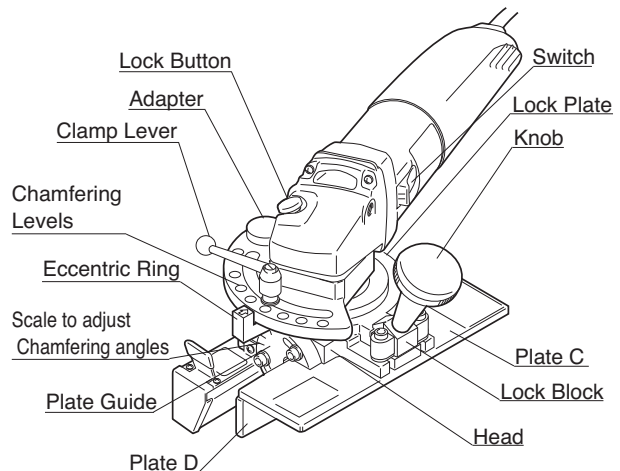

Fig.1

4. PREPARATIONS

WARNING

- Be Sure to turn the switch OFF and remove the power plug from power supply whenever setting up the tool.

4-1. Attaching the Dust Box

While pulling up the Dust Catcher in the arrow direction as illustrated, tighten 3 pcs. of Pan Head Screw 5 × 10 the Dust Box on the Head. (Fig.2)

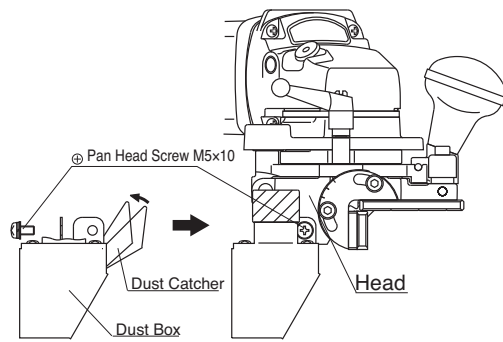

Fig.2

5. HOW TO OPERATE THE TOOL

⚠ WARNING

- Always wear suitable eye protection, suitable hearing protection, protective gloves, and respiratory protective equipment.

5-1. Start and Stop

⚠ CAUTION

- Always be sure the unit is in the OFF position before plugging the power cord into an outlet.

To start, slide the switch forward while pushing down it. (Fig.3)

To stop, slide back the switch. (Fig.3)

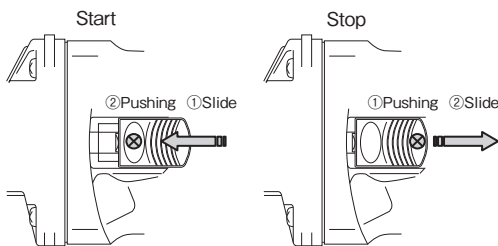

Fig.3

5-2. How to Adjust Chamfering Levels

⚠ WARNING

- Be sure to turn the switch OFF and remove the power plug from power supply whenever adjusting chamfering levels.
- The max. chamfering capacity
Stainless Steel: 3C
Mild Steel: 7C

- (1) Loosen the Clamp Lever. (Fig.4)
- (2) Rotate the arrow mark of the Eccentric Ring to the Scale to adjust chamfering levels for chamfering amount required. (Fig.4)
- (3) Tighten the Clamp Lever after the adjustment. (Fig.4)
 The level guide is only for reference. If accurate

chamfering is required, set the tool at a chamfering level about 0.5 smaller than the desired one. Try a test cut. Then adjust the tool for accurate chamfering.

In the case of Mild Steel

You can select chamfering levels from 0 to 7C freely. The maximum chamfering capacity for one-cut is 4C. For 4C to 7C, chamfer a workpiece twice or three times.

(Ex. 7C: 4C → 5.5C → 7C Total 3 times)

In the case of Stainless Steel

You can select chamfering levels from 0 to 3C freely. Chamfer the desired volume at a time without dividing the chamfering job to several times.

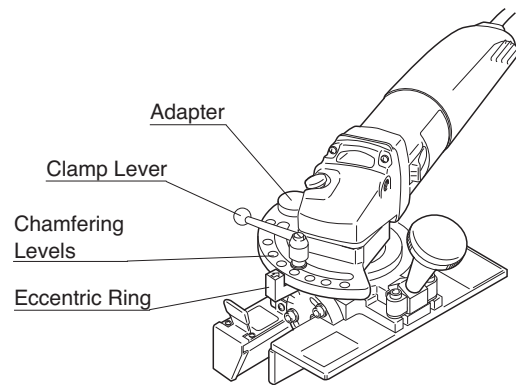

Fig.4

5-3. Adjustment of Radius Chamfering in Amount

- (1) Fix a radius chamfering Indexable Inserts.
- (2) Loosen the Clamp Lever. (Fig.4)
- (3) Rotate the arrow mark of the Eccentric Ring to the scale of the Adapter to adjust chamfering levels according to the size of the radius chamfering Indexable Inserts.
- (4) Tighten the Clamp Lever after the adjustment.
- (5) Conduct a test cutting. Readjust the Clamp Lever, so that sizes A and B become identical. (Fig.5)

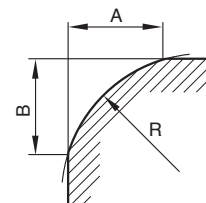

Fig.5

5-4. How To Adjust Chamfering Angle

⚠ WARNING

- Be sure to turn the switch OFF and remove the power plug from power supply whenever adjusting chamfering angle.

- (1) Loosen the Hex. Socket Head Cap Screws ① (4pcs) on both ends on the Plate Guide ② of Head ③. (Fig.6)
- (2) Move the Plate Guide ② so that the scale of desired angle can align to the Guide Mark ④.
- (3) Tighten the Hex. Socket Head Cap Screws ①.

The tool has the limit of chamfering width which depends on a chamfering angle. (Fig.7, Table.1)

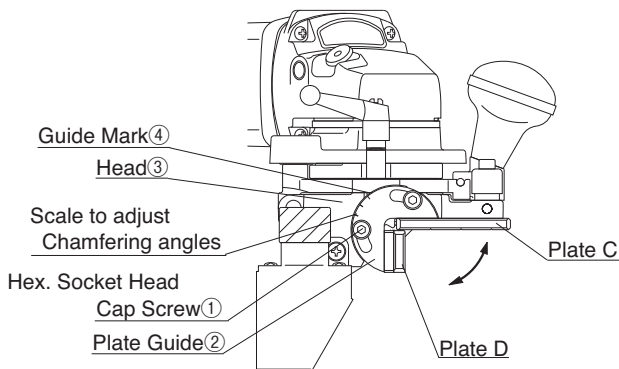

Fig.6

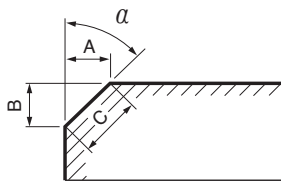

Fig.7

Chamfering Angle	Stainless Steel(mm)			Mild Steel(mm)		
	A	B	C	A	B	C
α						
45°	3	3	4.2	7	7	9.9
30°	2.2	3.8	4.4	3.8	6.6	7.6
15°	1	3.8	3.9	1.5	5.6	5.8

Table.1

5-5. Before Cutting

- (1) When you start to work from the corner as shown in Fig.8, cut off the corner first with grinder etc., then start.

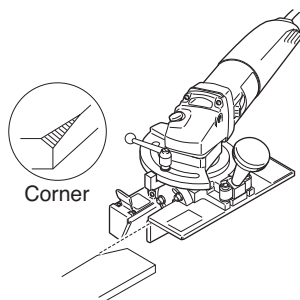

Fig.8

- (2) Before start chamfering, make sure that the Switch is set on and the Indexable Insert is rotating. Then,

apply the tool to the workpieces. The Indexable Inserts may be damaged if the Switch is set on after Indexable Inserts are pressed on the workpieces or they may also be damaged if they are pressed to the workpieces abruptly.

- (3) The workpieces should be fixed as much as possible while working.

5-6. Feeding Speed

Be sure you should avoid quick feeding or heavy shock. Please refer to Table.2.

Stainless Steel	3cm/sec
Mild Steel	2cm/sec

Table.2

5-7. How To Operation

⚠ WARNING

- Be sure to turn the switch OFF and remove the power plug from power supply whenever adjusting chamfering levels.
- The workpieces should be fixed as much as possible while working.

- (1) Select the chamfering level.
- (2) Make sure that the Switch is set at "OFF" position and connect the power plug to the power supply.
- (3) Hold the Housing up. Start the tool.
- (4) Hold the Housing and Knob firmly. Apply the tool on to the workpiece along with the direction (shown on the Plate C) carefully.

In case of chamfering stainless steel, chamfer deep to the desired chamfering level by one span of operation. Repeat of chamfering makes the life of Indexable Insert shorter.

5-8. Radius Chamfering

- By using radius chamfering Indexable Inserts, radius chamfering job can be done.
- Radius chamfering Indexable Insert is an optional accessory.

- (1) Select the radius chamfering.
- (2) Make sure that the Switch is set at "OFF" position and connect the power plug to the power supply.
- (3) Hold the Housing up. Start the tool.
- (4) Hold the Housing and Knob firmly. Apply the tool on to the workpiece along with the direction (shown on the Plate C) carefully.

※ On Tangential Line Cutting

Because of the constructional reason, it is possible to make a radius tangential line cutting on the

side facing the Plate D by adjusting the Head, but impossible on the upper side facing the Plate C. For making a radius tangential line cutting on the upper side, conduct in a following manner.

- (1) Place the tool on workpiece with Plate C on upper surface of workpiece and Plate D on side surface, as indicated in Fig.9. Then, turn the Eccentric Ring to adjust the Indexable Inserts to cut properly side surface, and conduct the first cut. (see Fig.10)
- (2) Next, placing Plate C on side surface and Plate D on upper surface, conduct the second cut.
- (3) In this case, slight seam may be left in center of chamfered surface. (Fig.11)

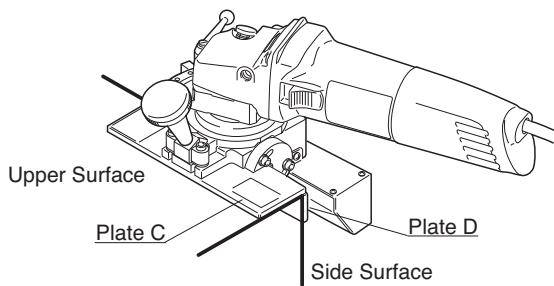

Fig.9

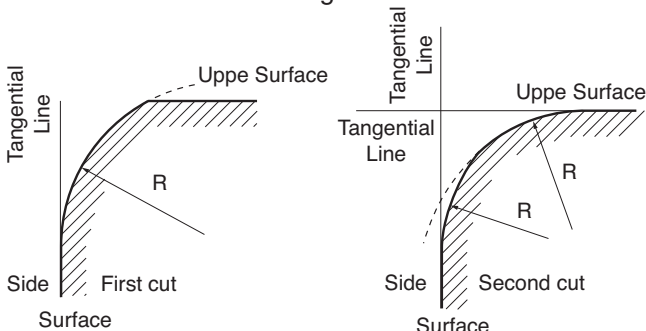

Fig.10

Fig.11

5-9. How To operation the Dust Box

WARNING

- Be sure to turn the switch OFF and remove the power plug from power supply whenever setting up the tool.
- The Dust Box is much heated right after the operation. Always wear gloves in handling the Dust Box.

CAUTION

- Frequently throw away the chips in the dust box before pilling up. If the tool is operated with the dust box filled with the chips, it badly affects finishing surfaces shorten the life of Indexable Insert.

Hold the motor firmly, and throw away the chips by opening the lid. (Fig.12)

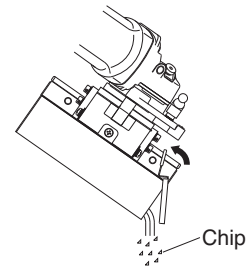

Fig.12

5-10. Restart Prevention Function

If the power is failed or the tool is accidentally unplugged from the power supply while in operation, the restart prevention function will be automatically activated when the power is restored. The restart prevention function will keep the motor of the tool from running even if the power is recovered or you put in the plug again.

To resume work, turn off the switch and then turn it on once again.

5-11. Kick Back Stop

When a big shock is given to the cutter during operation, the motor will stop automatically to protect the operator and the tool.

Chamfering can only be resumed once the switch is turned on again.

5-12. How To Chamfer Outer Diameter

WARNING

- Be sure to turn the switch OFF and remove the power plug from power supply whenever the accessories are attached or removed.

The tool can be used on the workpieces at the minimum diameter of 300mm by adjusting dimension A of both Hex. Socket Set Screws (8 × 25 special) ① in either direction. (Fig.13)

Remember that this operation requires the workpieces of at least 12mm length. (Fig.14)

- (1) In the case of constant R (Circle), install two Hex. Socket Set Screws (8 × 25 special) ① on Plate D and tighten with Hex. Nuts. Make sure that the dimension A of the left and the right screws are equal.

Chamfering on an outer diameter of O.D. 200mm – O.D. 300mm can done by placing the Hex. Nut on the other side of Plate D. (Fig.13, 14)

- (2) In the case of variable R (Oval), remove one of the two Hex. Socket Set Screws (8 × 25 special) ① .

Remember that chamfering level changes depending on the radii in this case.

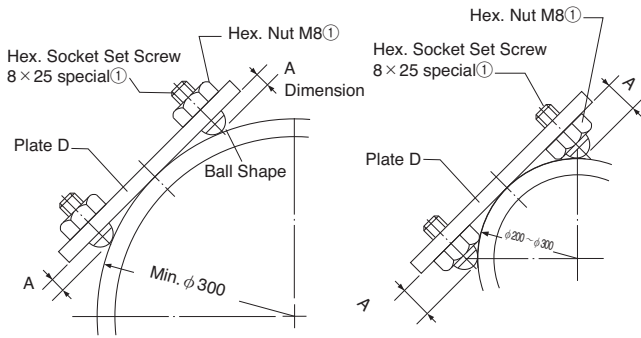

Fig. 13

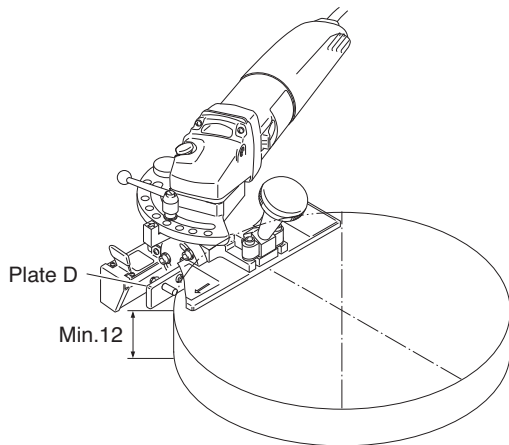

Fig. 14

6. HOW TO REPLACE INDEXABLE INSERT

⚠ WARNING

- Be sure to turn the switch OFF and remove the power plug from power supply whenever replacing Indexable Insert.
- The Indexable Insert and the Holder are much heated right after the operation. Always wear gloves in handling the Indexable Insert and the Holder.

- (1) Lay down the Knob with it pulled up. (Fig.15, 16)
- (2) Open the Lock Plate with the Knob laid down. (Fig.17)
- (3) Remove the Indexable Insert Set Screw using the Spanner T-15D attached to take off the Indexable Insert. (Fig.17)
- (4) Mount a new Indexable Insert (including use of reverse surface) paying attention to the direction of the Indexable Insert. (Fig.17)
- (5) Close the Lock Plate with the Knob laid down and lay the Knob aside to lock it. (Fig.18)

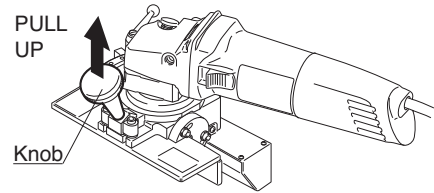

Fig. 15

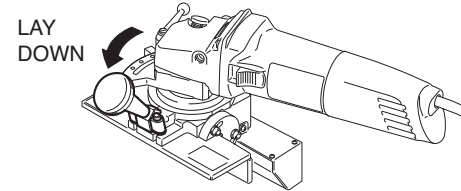

Fig. 16

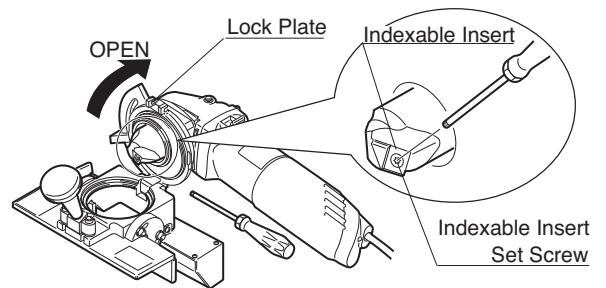

Fig. 17

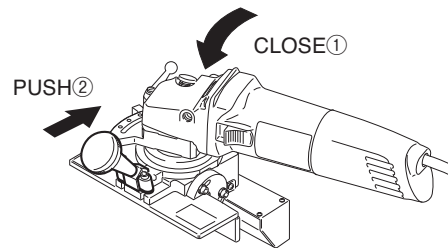

Fig. 18

7. MAINTENANCE AND INSPECTION

⚠ WARNING

- Be sure to turn the switch OFF and remove the power plug from power supply during maintenance and inspection.
- Perform periodic inspection to check for loosening of the attachment screws for each part. Retighten loose screws as required.

7-1. Replacing the Carbon Brushes

- After replacing the carbon brushes, always run the unit for at least 10 minutes under no load conditions.

Periodically check for wear on the Carbon Brushes, because as rectification deteriorates the likelihood

of a failure brush reaches around 5mm, follow the procedure below to replace the brush with new ones.

● **Because a cut-off brush is used, when it is worn electricity is automatically cut-off. If this happens, replace the carbon brush according to the following procedure.**

- (1) Loosen the Pan Head Tapping Screw and remove the Cover. (Fig.19)
- (2) Lift the spiral Spring, remove the Carbon Brush and replace it with the new Carbon Brush. (Fig.20)
- (3) Check that the cable is correctly connected.
- (4) Attach the Cover and securely tighten the Pan Head Tapping Screw. Be sure that the Tapping Screw is correctly threaded; do not attempt to tighten if the screw is cross-threaded.

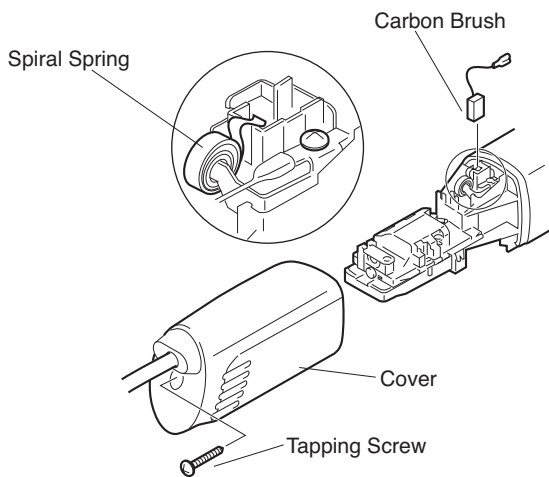

Fig.19

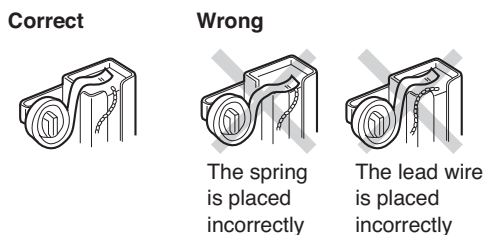

Fig.20

company from whom you purchased the tool or an authorized dealer.

In ordering parts and components give each part number, part name and quantity required.

Use only NITTO genuine parts.

10. OPTIONAL PARTS

Part No.	Description	Qty
TB01159	Indexable Insert with Hole 12.7	10pcs
TB01791	Indexable Insert 12.7 sq. R2	10pcs
TB01651	Indexable Insert 12.7 sq. R3	10pcs
TB01790	Indexable Insert 12.7 sq. R4	10pcs
TB02539	Attachment for Small Dia. Pipe ※	1set

※ For Steel Pipe Out Dia. 80mm – 200mm

8. CONDITION FOR USE

Burn-out chips suggest that either the feed speed is too slow or the Indexable Insert has worn-out.

Change the cutting conditions or check the conditions of the Indexable Insert.

9. ORDERING SERVICE PARTS

For further operational and handling information or for replacement of parts and components, contact the

11. EXPLODED DIAGRAM : EMB-0307B

WARNING

This diagram is for your reference only. Do not attempt to service or repair the Tool. Do not take the Tool apart. Contact an authorized Nitto dealer for all service and repair of the Tool. Improper service and repair can cause accidents and severe injuries. Never attempt to modify the Tool. Never attempt service or repair the Tool yourself.

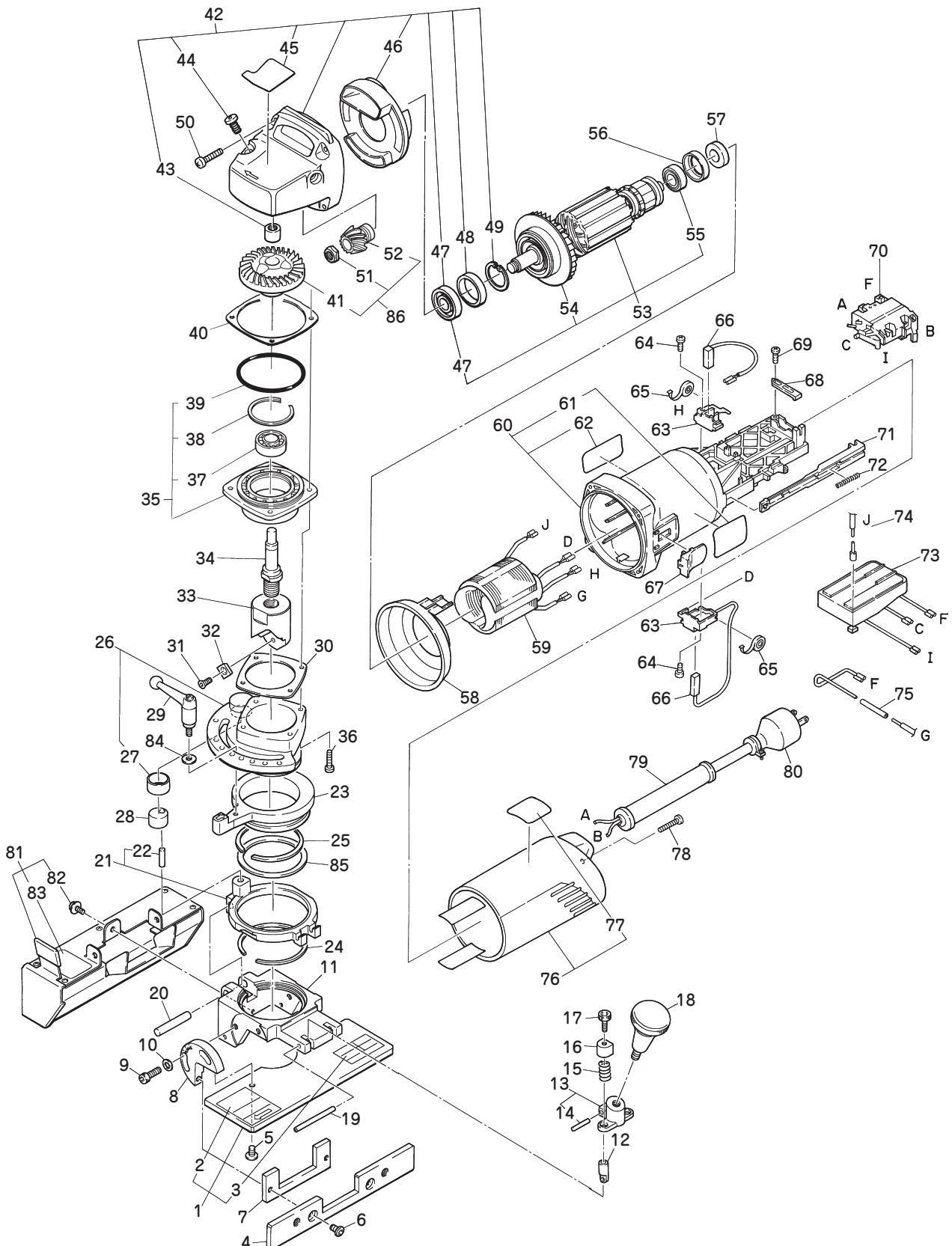

The part numbers with () are included in the Ass'y parts written above them.

No.	Part No.	Description	Qty	Price
1	TB02632	Plate C Ass'y	1set	
2	(TP16975)	Label A (Caution)	1	
3	(TQ01684)	Label B (Chamfering level)	1	
4	TQ03415	Plate D	1	
5	TQ00211	Hex. Socket Head Screw 5×8	2	
6	TQ00214	Hex. Socket Head Screw 5×12	2	
7	TQ04308	Plate Supporter	1	
8	TP18065	Plate Guide	2	
9	TP02862	Hex. Socket Head Cap Screw 5×15	4	
10	TP02152	Plain Washer M5	4	
11	TQ04301	Head	1	
12	TQ04305	Shaft	2	
13	TB03291	Lock Block A Ass'y	1set	
14	(TQ04306)	Parallel pin A4×25	1	
15	TQ10807	Spring 1.1×10.5×15	2	
16	TQ04303	Cover	2	
17	TP00021	Hex. Socket Head Cap Screw 5×10	2	
18	TA93017	Knob Ass'y	1set	
19	TQ04534	Spring Pin 5×50 AW	1	
20	TQ04300	Parallel Pin A8×35	1	
21	TB03290	Lock Plate Ass'y	1set	
22	TQ04298	Parallel Pin A6×20	1	
23	TQ04296	Eccentric Ring	1	
24	TQ04310	Concentric Snap Ring WR-65	1	
25	TP18056	Concentric Snap Ring WR-52	1	
26	TB03392	Adapter Ass'y	1set	
27	(TQ04442)	Bushing LFB-1810	1	
28	TQ04297	Eccentric Top	1	
29	TQ04294	Clamp Lever KR5×15	1	
30	TQ04328 TQ04329 TQ04330 TQ04331 TQ04332	Spacer t0.05 (for adjustment) Spacer t0.1 (for adjustment) Spacer t0.2 (for adjustment) Spacer t0.3 (for adjustment) Spacer t0.5 (for adjustment)		
31	TQ01629	Indexable Insert Set Screw 4×7	1	
32	TB01159	Indexable Insert with Hole 12.7 (10pcs. / Set)	1set	
33	TQ03412	Holder	1	
34	TQ03795	Spindle	1	
35	TB08179	Bearing Case Ass'y F	1set	
36	(TQ10600)	Hex. Socket Head Cap Screw 4×18	4	
37	(TP16791)	Ball Bearing 6201LU / 2A	1	
38	(TQ11713)	Concentric Snap Ring IRTW-32	1	
39	(TQ01578)	O-ring 46×48×1	1	
40	TQ03822 TQ03823 TQ03824 TQ03825	Spacer For Bearing Case 0.1mm Spacer For Bearing Case 0.15mm Spacer For Bearing Case 0.2mm Spacer For Bearing Case 0.3mm		
42	TB08180	Gear Case Ass'y D	1set	
43	(TP16788)	Needle Bearing HK0808	1	
44	(TB07982)	Lock Button Ass'y	1set	
45	(TQ03840)	Label Caution	1	
46	(TQ04210)	Air Deflector Ring	1	
47	(TQ04203)	Ball Bearing 608LU	1	
48	(TP16785)	Gum Ring A	1	

No.	Part No.	Description	Qty	Price
49	(TQ04214)	Retaining Ring	1	
50	TQ12612	Pan Head Tapping Screw 4×25	4	
53	TB07984	Armature Ass'y 230V	1set	
54	(TQ04200)	Fan	1	
55	(TP06386)	Ball Bearing 607ZZ	1	
56	TQ11753	Protective Cover	1	
57	TQ11752	Magnet	1	
58	TQ04209	Fan Guide	1	
59	TQ11774	Stator 230V	1	
60	TB08181	Motor Case Ass'y 230V	1set	
61	(TQ12817)	Label Model Number	1	
62	(TQ12818)	Label Warning	1	
63	TQ11746	Brush Holder	2	
64	TQ04216	Pan Head Tapping Screw 2.9×9.5	2	
65	TQ11782	Brush Spring	1	
66	TB03219	Carbon Brush Ass'y	1set	
67	TP16803	Switch Button	1	
68	TP16772	Cord Clamp	1	
69	TQ11761	Pan Head Tapping Screw 3.9×13	1	
70	TQ11733	Switch	1	
71	TQ04206	Slider	1	
72	TP16804	Spring 0.5×45×29	1	
73	TQ11735	Governor 230V	1	
74	TQ11740	Insulation Sleeve	1	
75	TQ11742	Connecting Cable	1	
76	TB08089	Motor Cover Ass'y	1set	
77	(TQ03819)	Label Electronic	1	
78	TQ04217	Pan Head Tapping Screw 3.9×19	1	
79	TQ11766	Cord Armor 230V	1	
80	TQ11734	Cabtyre Cord	1	
81	TB08750	Dust Box Ass'y	1set	
82	(TQ04475)	Pan Head Screw 5×10	3	
83	(TQ12819)	Label Caution Dust Box	1	
84	TQ04642	Plain Washer M5 12×5.5×0.8	1	
85	TQ04775 TQ04776 TQ04777	Spacer t0.1 (for Lock Plate) Spacer t0.2 (for Lock Plate) Spacer t0.05 (for Lock Plate)		
86	TB08530	Gear Ass'y	1set	
41	(TQ12502)	Gear 1.25×41	1	
52	(TQ12503)	Pinion 1.25×12	1	
51	(TQ12944)	Pinion Nut	1	

Accessories

No.	Part No.	Description	Qty	Price
		Indexable Insert with Hole 12.7	1	
	TQ01629	Indexable Insert Set Screw 4×7	1	
	TB03219	Carbon Brush Ass'y	1set	
	TP01939	Hex. Socket Screw Key 4	1	
	TQ01683	Spanner T-15D	1	
	TP08584	Hex. Nut M8	2	
	TP17133	Hex. Socket Set Screw 8×25	2	
	TQ12820	Instruction Manual	1	
	TQ12821	Declaration of Conformity	1	



■ Overseas Affiliates / Offices

NITTO KOHKI U.S.A., Inc.

4525 Turnberry Drive, Hanover Park, IL 60133, U.S.A

Tel: (1)-630-924-9323 Fax: (1)-630-924-0303
<http://www.nittokohki.com/index.html>

NITTO KOHKI EUROPE Co., Ltd.

Unit 21, Empire Centre, Imperial Way,
Watford Hertfordshire, WD24 4TS, United Kingdom

Tel: (44)-01923-239668 Fax: (44)-01923-248815
<http://www.nitto.co.uk/>

NITTO KOHKI DEUTSCHLAND GmbH

Lerchenstr. 47, D-71144 Steinenbronn, Germany

Tel: (49)-7157-22436 Fax: (49)-7157-22437
<http://www.nitto-kohki.de/>

NITTO KOHKI AUSTRALIA Pty. Ltd.

77 Brandl Street, Eight Mile Plains QLD 4113,
Australia

Tel: (61)-7-3340-4600 Fax: (61)-7-3340-4640
<http://www.nitto-australia.com.au/>

NITTO KOHKI Co., Ltd. Singapore Branch

10 Ubi Crescent #01-62, Ubi Techpark Lobby D,
Singapore 408564

Tel: (65)-6227-5360 Fax: (65)-6227-0192
<http://www.nitto-kohki.co.jp/e/nksb/>

NITTO KOHKI Co., Ltd. Shanghai Representative Office

#1117 Ruijing Building, Maoming South Road,
Shanghai 200020 China

Tel: (86)-21-6415-3935 Fax: (86)-21-6472-6957
<http://www.nitto-kohki.cn/>

NITTO KOHKI Co., Ltd. Shenzhen Representative Office

#0726 International Culture Building, 3039, Shennan
Zhong Rd., Futian District, Shenzhen, 518003 China

Tel: (86)-755-8375-2185 Fax: (86)-755-8375-2187
<http://www.nitto-kohki.cn/>

NITTO KOHKI Co., Ltd. Bangkok Representative Office

38Q, House Convent Bldg, 7th Floor, Unit 7A,
Convent Rd, Silom, Bangkok, 10500 Thailand

Tel: (66) -2-632-0307 Fax: (66)-2-632-0308
http://www.nittobkk.com/eng_index.htm

EC DECLARATION OF CONFORMITY

We hereby declare that the following our product conforms with the essential health and safety requirements of EEC Directives.

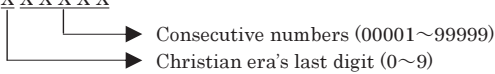
Product: ELECTRIC CHAMFERING TOOL
Model: MINI BEVELER: EMB-0307B
Serial No: X X X X X X

Manufacturer: NITTO KOHKI Co., Ltd.
2-9-4, Nakaikegami, Ohta-ku, Tokyo, 146-8555, Japan

Authorised Compiler in the Community:

Masatoshi Ogue
President
NITTO KOHKI EUROPE Co., Ltd.
Unit21, Empire Centre, Imperial Way, Watford Hertfordshire, WD24 4TS, UK
Tel: (44)-01923-239668 Fax: (44)-01923-248815

Directive : 98/37/EC and 2006/42/EC Machinery Directive
2006/95/EC Low Voltage Directive
2004/108/EC EMC Directive

The above product has been evaluated for conformity with above directives using the following European standards.
The technical construction file (TCF) for this product is retained at the above manufacturer's location.

Machinery Directive: EN ISO12100-1:2003, EN ISO12100-2:2003,
EN ISO14121-1:2007, EN60745-1:2006, others

Name: K.Kishi

Title: GENERAL MANAGER MACHINE TOOLS DIV.

Being the responsible person appointed and employed the manufacturer.