

INSTRUCTION MANUAL

PNEUMATIC RECIPROCATING SANDER

Please read this manual carefully before you attempt to use your tool so that you may use it properly and safely.

LINE SANDER Model LS-10 **PROFESSIONAL TOOL**



Specifications

Model	LS-10
Maximum Operating Pressure	0.6MPa
Air Consumption (No Load)	0.11 m ³ /min
Rated Speed (No Load)	4,000 min ⁻¹
Stroke Length	4mm(5/32")
Pad Size	55mm x 103mm(2-5/32" x 4-1/16")
Abrasive Paper Size	57mm x 140mm(2-1/4" x 5-1/2")
Mass (Weight)	0.75 kg
Sound Pressure Level	87 dB(A)
Sound Power Level	89 dB(A)
Vibration Level	8.4 m/s ²
Thread Size of Air Inlet	Rc1/8

Due to continuous product development/improvement the specifications and configurations in this document are subject to change without prior notice.



Manufactured by :

NITTO KOHKI Co., Ltd.

2-9-4, Nakaikegami, Ohta-ku,
Tokyo, 146-8555, Japan

Tel : (81)-3-3755-1111

Fax : (81)-3-3753-8791

E-mail : overseas@nitto-kohki.co.jp

URL : www.nitto-kohki.co.jp

Keep the manual handy – so you can use it whenever necessary.

Original Instructions

Thank you very much for your purchase of this **Nitto Kohki products**.





Before using your tool, please read this manual carefully so that you may use it properly to get the most out of it.

Please keep the manual handy - so you can use it whenever necessary.



- **English** : Please ask your dealer or distributor for instruction manual in local language(s).
- **German** : Bitte fragen Sie Ihren Händler nach eine Betriebsanleitung in Landessprache.
- **French** : S'il vous plait, veuillez demandez à votre fournisseur de manuel instruction en langue locale.
- **Spanish** : Por favor, contacte con su distribuidor para el manual de instrucciones en español.
- **Portuguese** : Por favor pessa ao seu agente ou distribuidor o manual de instruções em linguagem local.
- **Italian** : Per Manuale Istruzioni in lingua locale Vi preghiamo di rivolgerci al rivenditore o distributore.
- **Dutch** : Vraag uw handelaar om een nederladstalige gebruiksaanwijzing.
- **Swedish** : Be er lokala Åtreförsäljare eller distributör om manualer på svenska.
- **Danish** : Venligst henvend Dem til den danske distributør for instructions manualer.
- **Polish** : Proszę pytać swojego dealera lub dystrybutora o instrukcje obsługi w języku localnym.
- **中文** : 請向當地供應商或經銷商詢問中文使用說明書

CONTENTS	page
IMPORTANT SAFETY INSTRUCTIONS	2
GENERAL: TOOLS	2
GENERAL: PNEUMATIC TOOLS	3
INSTRUCTIONS FOR THIS TOOL	4
1. USAGE	4
2. CHECK THE CONTENTS OF THE PACKAGE	4
3. AIR SUPPLY	4
4. PREPARATIONS	4
5. ATTACH ABRASIVE PAPER	4
6. HOW TO OPERATE THE TOOL.....	5
7. ATTACH THE BLOCK RUBBER PAD	5
8. STORAGE	6
9. ORDERING SERVICE PARTS	6
10. OPTIONAL PARTS	6
11. EXPLODED DIAGRAM : LS-10	7

PICTOGRAM

-  Warning: It might be dangerous to operate the tool if the instructions supplied are not followed.
-  Using this tool improperly could result in serious injury. Read the instruction manual before using.
-  Always wear suitable eye protection.
-  Always wear suitable hearing protection.
-  Always wear respiratory protective equipment (PPE).

The following Safety notations are used throughout the manual to highlight safety precautions for the user and for the tool.

	WARNING:	Indicates a potentially hazardous situation which, if not avoided by following the instructions given, could result in death or serious injury.
	CAUTION:	Indicates a potentially hazardous situation which, if not avoided by following the instructions given, could result in injury or material damage.

Please note, however, that failure to observe safety precautions under the “ **Caution**” category could result in a serious occurrence depending on the situation: please observe all safety precautions in the manual.

Caution: Important precautions for tool setup, operation and maintenance.

IMPORTANT SAFETY INSTRUCTIONS

When using the tool, please observe the safety precautions below to prevent possible accident or injury.

GENERAL: TOOLS

WARNING

TO OPERATORS

- **Wear proper clothing for the type of work being done.**
Take care so that clothing, ties, hair etc. will not become entangled with the moving parts. If items become entangled it will cause the operator to be pulled towards the tool and lead to possible cause of accident or injury.
- **Always wear suitable eye protection.**
Remember, regular glasses are not safety glasses. The lenses are only shock resistant, which will not give you sufficient eye protection you may need in your working environment.
- **Always wear suitable hearing protection.**
- **Wear respiratory protective equipment (PPE).**
Wear respiratory protective equipment (PPE) when working in an environment where dust particles are generated in operation.
- **Avoid working posture that is too stressful.**
Always ensure a firm footing and well balanced posture.
- **Do not operate the tool if you are too tired.**
- **Never touch any moving parts of the tool when running.**

ABOUT WORK AREA

- **Keep the work area clean.**
Cluttered work areas (e.g. workbench) invite accidents.
- **Carefully select the work area.**
Do not expose tool to rain.
Do not use tool in a wet or soaked area.
See that the work area is adequately illuminated.
- **Never work near inflammable liquid or in a potentially explosive atmosphere.**
- **Keep children away from the work area.**
Keep children and unauthorized people away from the work area to avoid accident or injury.

BEFORE OPERATION

- **Inspect tool before use.**
Before using, check that screws are securely tightened, that any protective cover or guard is securely in place, other parts are free from damage and that the tool runs as it should.
Check that moving parts are properly adjusted for positioning and tightened, that parts are free from damage and properly mounted, and that all other parts are in good condition for normal operation.
Should you find any damage to the protective cover or other part, replace it in accordance with the Operation Manual. If there are no instructions in the Manual, please contact the sales agent through which you have purchased your tool or an authorized dealer near you for repair.
Likewise, if a switch failure occurs, contact sales agent through which you have purchased your tool or an authorized dealer near you for repair.
Do not use the tool if it does not start or stop with the start/stop switch.
- **Securely mount cutter**
An improperly mounted cutter may fly out, causing possible damage to the tool or injury to the operator.
- **Always remove spanner, wrench, etc., once adjustment has been made with them.**
- **Use a tool appropriate for the application.**
Avoid heavy-duty application that is beyond the capacity of tool.
- **Do not use the tool for purposes other than what it is designed for.**
- **Do not abuse tool.**
Use tool in accordance with the specifications: you'll get the most out of it while ensuring safety.
- **Securely fasten workpiece in place.**
Use a vice or clamp to securely fasten the workpiece in place. It is much safer this way than holding it in your hand, allowing you to operate the tool with both hands.

ABOUT HANDLING

- **How to store tool.**
When the tool is not used, store it in a dry area and out of reach of children.
- **How to carry tool.**
Do not touch the start switch while the tool is being carried.
- **Do not leave the tool unattended while it is running.**
Turn off the start switch and disconnect the tool from power source. Do not leave the work area until the tool comes to a complete stop.

MAINTENANCE/SERVICE

- **Do not take apart or modify tool.**

Disassembly or modification carried out without the supervision of a qualified or authorized service engineer could result in an accident or injury.

- **Inspect cutting tool and accessories, etc.**

Always check to see that cutting tool and accessories, etc. are in good operating condition without damage or deterioration before you mount them on the tool. Should you find any damage to an accessory or part, please contact sales agent through which you have purchased your tool or an authorized dealer near you for repair.

- **Check parts for damage.**

When you have found damage to accessory or other part, carefully check the damaged part to determine the extent of influence it has upon the functions of the tool – that is, determine whether it can still perform its normal functions.

Check to see that the linkage of the moving parts is OK, that all parts are OK without damage, that they are properly mounted, and that the tool functions normally. Should you find any damage to an accessory or part that may hamper proper functioning of the tool, please contact sales agent through which you have purchased your tool or an authorized dealer near you for repair.

- **Have your tool repaired at an authorized Nitto Service Center.**

For repair or parts replacement, please contact the sales agent through which you have purchased your tool or an authorized dealer near you.

- **Use only Nitto genuine parts.**

Use of improper parts may result in serious accident. To obtain a Nitto genuine part, consult this Manual or contact the sales agent from which you have purchased your tool directly.

- **Do not detach label or nameplate from tool.**

When a label/nameplate gets damaged, worn or becomes missing, contact the sales agent through which you have purchased your tool or Nitto Kohki Co. Ltd, directly for a replacement.

DISPOSAL

- When a tool is taken permanently out of service, it is advised that the tool is disassembled, degreased and parts separated by material and recycled locally in the appropriate manner.

GENERAL: PNEUMATIC TOOLS

WARNING

- **Use appropriate air pressure.**

Excessively high air pressure will increase the tool number of revolutions or strokes causing not only potential premature failure/breakage but could also lead to an unexpected accident or injury.

- **Connect tool to air supply line.**

There are various types of pipes running in a factory in addition to the pneumatic line (such as oxygen, nitrogen, gas and water). For this reason, always ensure that you are connecting to the pneumatic line.

- **Start tool properly.**

Turn the start switch OFF before connecting to the air supply line.

- **Always disconnect the tool from the air supply line before putting on/taking off any accessory and prior to carrying out any maintenance work.**

- **Avoid exposure to exhaust air.**

Pneumatic tool exhaust air contains oil and contaminated moisture. Make sure the exhaust air is not directed towards your face or anyone else within the work area.

- **Keep tool off electricity.**

This pneumatic tool is not electrically insulated. To avoid a potential electric shock do not use where there is a possibility of coming into contact with live electricity.

CAUTION

- **Handle tool carefully.**

Abusive use of tool could invite failure or accident. Do not throw, drop or shock the tool.

- **Handle connecting hose carefully.**

Do not carry the tool by the air hose. Do not pull the air hose to disconnect.

INSTRUCTIONS FOR THIS TOOL

About Your Tool

WARNING

- **Wear protective glasses and a dustproof mask**
Operation generates chips and dust particles, etc. which may cause eye and/or respiratory injury. Always use PPE (Personal Protective Equipment) for eye and respiratory protection.
- **Always turn off the air supply and disconnect the air supply hose beforehand whenever replacing Abrasive Papers.**
- **Be sure to keep hands clear of moving parts.**
- **Air pressure at the sander inlet must not exceed 0.6 MPa.**
- **Always replace damaged, bent or severely worn Pads.**
Do not use a Pad that has been subjected to an Abrasive Paper failure.
- **Avoid grinding at pad edge or banging pad edge against work material or other object, as this can shorten tool life.**

1. USAGE

This tool is for sanding workpieces using Abrasive Paper.

2. CHECK THE CONTENTS OF THE PACKAGE

Check the contents and make sure that the tool does not have any damage which may have occurred during transportation. The contents should correspond to the list as follows. In case of damage/missing parts, please contact the sales agent from whom you purchased the tool.

Package Contents	Qty	check
LINE SANDER LS-10	1set	
Hose E Ass'y	1set	
Bushing R1/4 x NPT1/4	1	
Base Plate A Ass'y	1set	
Block Rubber Pad Sub Ass'y	1set	
Abrasive Paper #240	5	
Abrasive Paper #320	5	
Instruction Manual	1	
Declaration of Conformity	1	
Caution for Use	1	

3. AIR SUPPLY

3-1. Air Pressure

Adjust air pressure with the air regulator to the appropriate level for the pneumatic tool used.

Air pressure that is too low will stop the tool from operating at full capacity.

Air pressure that is too high may cause damage to the tool.

3-2. Air Line (Fig.1)

Use a 9.5 mm (3/8") I. D. connecting hose between the compressor and the tool.

Drained water, etc., if flown into the tool, could cause tool failure. Install an air filter between the compressor and the tool.

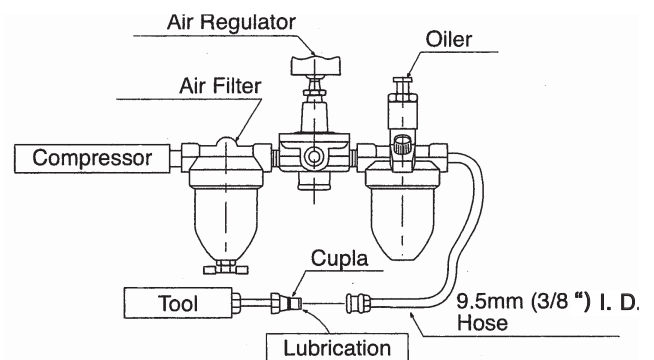

Fig. 1

3-3. Lubrication

Install an oiler between the compressor and the tool. Use the machine oil ISO VG-10. Failure to lubricate as required may result in damage to the tool. Use of oil that is too thick will reduce the performance of the tool.

4. PREPARATIONS

4-1. Thread Size of Hose Fitting

The product comes with a metal fitting with Rc(metric) thread. Connect the Bushing R thread x NPT thread included as standard accessories, if you would like to have American NPT thread instead.

5. ATTACH ABRASIVE PAPER

WARNING

- **Always turn off the air supply and disconnect the air supply hose beforehand whenever replacing Abrasive Papers.**

5-1. Abrasive Paper

Cut standard size paper (9" x 11") into 8 pieces, as shown in Fig.2. For dry sanding, use an open cost type Abrasive Paper with silicon carbide or aluminum

oxide abrasive grains to prevent clogging, improve grinding efficiency, and prolong the life of the paper.

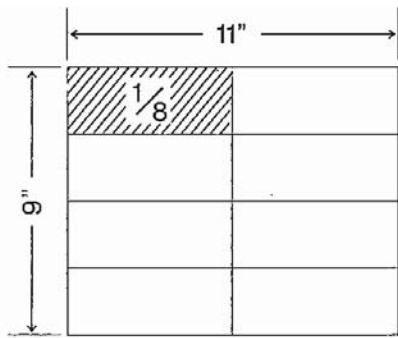

Fig. 2

5-2. Attach Abrasive Paper

Raise the circular knob at the end of the Clamp Spring (2 points), pull to the side, and push it down. The paper clamp will then open, push in Abrasive Paper at this point, raise the circular knob and insert the Clamp Spring inside the Clamp Stopper. This completes fitting the Abrasive Paper. Refer to Fig.3 and Fig.4. Install Abrasive Paper tightly. If both sides are not clamped completely (Fig.5), cutting and sanding power will drop. Compare Fig.4 and Fig.5. Notice how in the incorrectly clamed figure, the cutting surface of the Abrasive Paper does not come in contact with the Rubber Pad.

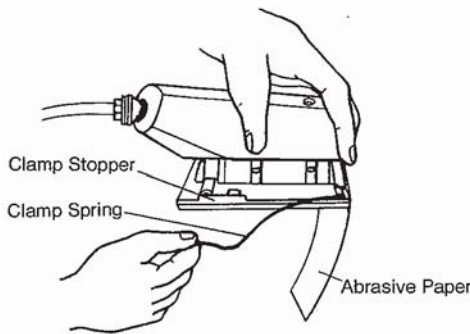

Fig. 3

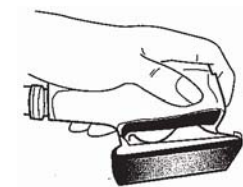

Fig. 4

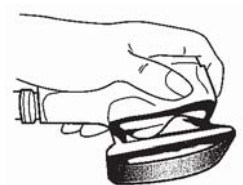

Fig. 5

5-3. In Case of Using Double-Sided Adhesive Tape

Attach double-sided adhesive tape to the sponge part then attach the Abrasive Paper to the tape.

5-4. In Case of Using Spray Adhesive

Spray the Abrasive Paper with adhesive then attach it to the sponge. Since the Abrasive Paper must be removed after it has been used. Avoid using permanent adhesive. Paper adhesives are available.

6. HOW TO OPERATE THE TOOL

6-1. Start and Stop

To start, push the Trigger all the way towards the body. To stop, pull the Trigger all the way out away from the body.

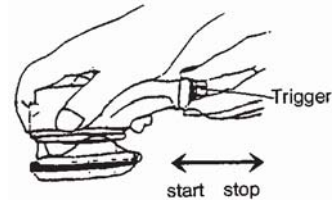

Fig. 6

6-2. Sanding Pressure

This Tool is excellent in preparing flat surfaces. Make sure the entire surface of Rubber Pad contacts work surface evenly during operation.

7. ATTACH THE BLOCK RUBBER PAD

! WARNING

Always turn off the air supply and disconnect the air supply hose.

Loosen 4 screws (Pan Head Screw M4 x 8), and remove the Rubber Pad. Loosen 4 screws (Countersunk Flat Head Screw M4 x 8), and remove Base Plate Ass'y.

Fix the Base Plate A Ass'y on the Cylinder Case by the screws (M4). The Block Rubber Pad can be fixed by the magic tape to be replaced easily.

The Block Rubber Pad can be cut as required according to the usage.

8. STORAGE

CAUTION

When tool is not used, store it out of reach of children.

Avoid storing the tool in a location subject to high humidity. If the tool is left as it is used, residual moisture on the inside can cause rusting. Before storing, and after operation, oil the tool at the air inlet with machine oil ISO VG-10 and run it for a short time.

9. ORDERING SERVICE PARTS

For further operational and handling information or for replacement of parts and components, contact the company from whom you purchased the tool or an authorized dealer.

In ordering parts and components give each part number, part name and quantity required.

Use only NITTO genuine parts.

10. OPTIONAL PARTS

Part No.	Description	Qty
TP03803	Adhesive Spray	1
TP04270	Double Side Adhesive Tape	1
TA9A265	Abrasive Paper #100	200pcs
TA9A266	Abrasive Paper #120	200pcs
TA9A267	Abrasive Paper #150	200pcs
TA9A268	Abrasive Paper #180	200pcs
TA9A269	Abrasive Paper #240	200pcs
TA9A270	Abrasive Paper #280	200pcs
TA9A271	Abrasive Paper #320	200pcs
TB02244	Dust Collector Ass'y (Fig.7)	1set

CAUTION

In case of using Dust Collector Ass'y, use the Abrasive Paper exclusive for the Dust Collector Ass'y.

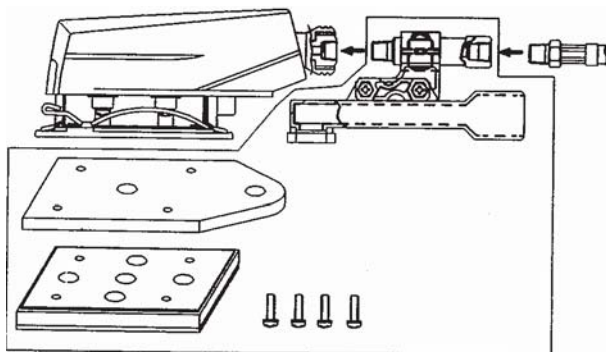

TB02244 Dust Collector Ass'y

Fig. 7

11. EXPLODED DIAGRAM : LS-10

WARNING

This diagram is for your reference only. Do not attempt to service or repair the Tool. Do not take the Tool apart. Contact an authorized Nitto dealer for all service and repair of the Tool. Improper service and repair can cause accidents and service injuries. Never attempt to modify the Tool. Never attempt service or repair the Tool yourself.

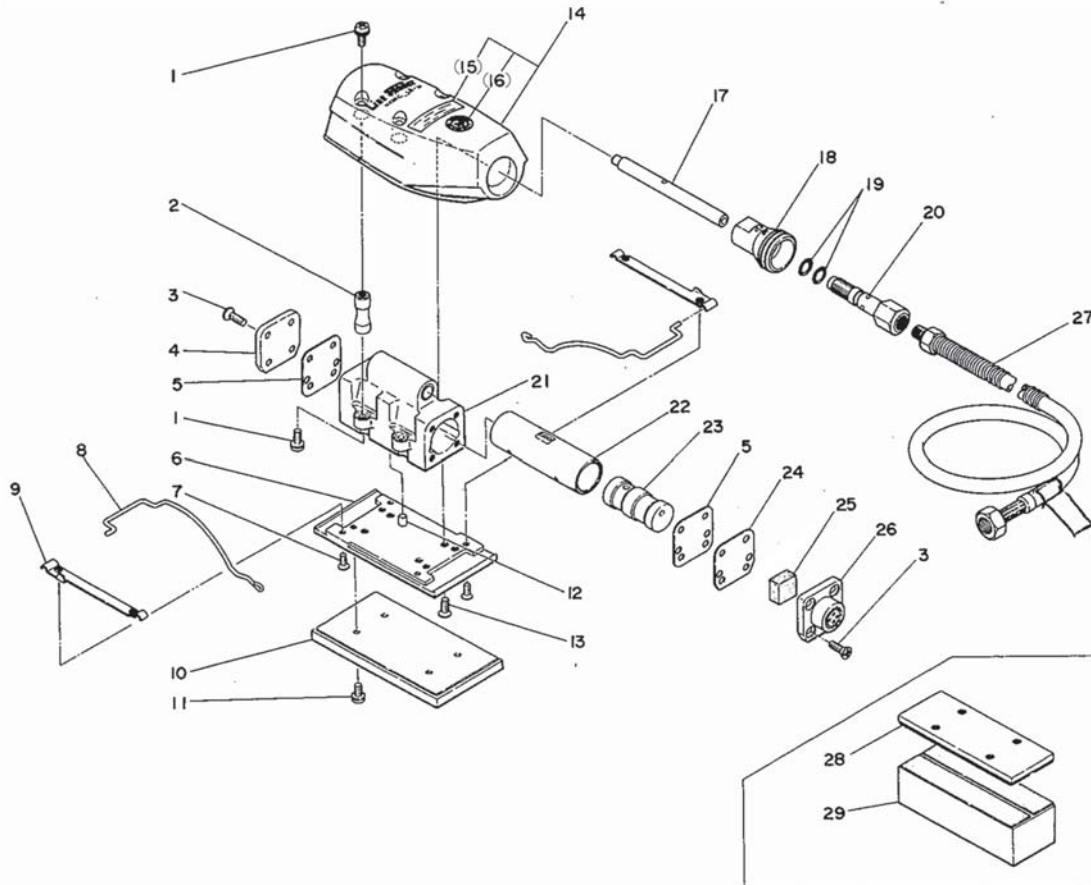

The part numbers with () are included in the Ass'y parts written above them.

No.	Part No.	Description	Qty	Price
1	TP11245	Pan Head Screw M4 x 10	8	
2	TA96664	Rubber Support Ass'y	4 sets	
3	TP04217	Raised Countersunk Head Screw M4 x 10	8	
4	TP11249	Cap A	1	
5	TP11251	Packing	2	
6	TP11259	Base Plate	1	
7	TQ10725	Hex. Socket Countersunk Head Screw M3 X 6	4	
8	TP11260	Clamp Spring	2	
9	TP11261	Clamp Stopper	2	
10	TA96665	Rubber Pad Ass'y	1 set	
11	TP06290	Pan Head Screw M4 x 8	12	
12	TP12208	Pin 4 x 6.5	1	
13	TP00123	Countersunk Head Screw M4 X 8	4	
14	TB08686	Housing Ass'y	1 set	
15	(TQ12752)	Label Warning CE Mark	1	
16	(TP04218)	Label NITTO	1	
17	TP11244	Guide Shaft	1	

No.	Part No.	Description	Qty	Price
18	TP05699	Trigger	1	
19	TP12004	O Ring P-10	2	
20	TP11258	Valve Nipple	1	
21	TA96660	Cylinder Case Sub Ass'y	1 set	
22	TP11247	Cylinder	1	
23	TP11248	Piston	1	
24	TP11254	Plate	1	
25	TP11253	Filter	1	
26	TP11250	Cap B	1	

ACCESSORIES

No.	Part No.	Description	Qty	Price
27	TB07904	Hose E Ass'y	1	
	TP02236	Bushing R1/4 x NPT1/4	1	
28	TA96738	Base Plate A Ass'y	1	
29	TA96739	Block Rubber Pad Sub Ass'y	1	
		Abrasive Paper #240	5	
		Abrasive Paper #320	5	
	TQ12755	Instruction Manual	1	
	TQ12756	Declaration of Conformity	1	



Overseas Affiliates / Offices

NITTO KOHKI U.S.A., Inc.

4525 Turnberry Drive, Hanover Park, IL 60133, U.S.A

Tel: (1)-630-924-9323 Fax: (1)-630-924-0303

<http://www.nittokohki.com/index.html>

NITTO KOHKI EUROPE Co., Ltd.

Unit 21, Empire Centre, Imperial Way,
Watford Hertfordshire, WD24 4TS, United Kingdom

Tel: (44)-01923-239668 Fax: (44)-01923-248815

<http://www.nitto.co.uk/>

NITTO KOHKI DEUTSCHLAND GmbH

Lerchenstr. 47, D-71144 Steinenbronn, Germany

Tel: (49)-7157-22436 Fax: (49)-7157-22437

<http://www.nitto-kohki.de/>

NITTO KOHKI AUSTRALIA Pty. Ltd.

77 Brandl Street, Eight Mile Plains QLD 4113,
Australia

Tel: (61)-7-3340-4600 Fax: (61)-7-3340-4640

<http://www.nitto-australia.com.au/>

NITTO KOHKI Co., Ltd. Singapore Branch

10 Ubi Crescent #01-62, Ubi Techpark Lobby D,
Singapore 408564

Tel: (65)-6227-5360 Fax: (65)-6227-0192

<http://www.nitto-kohki.co.jp/e/nksb/>

NITTO KOHKI Co., Ltd. Shanghai Representative Office

#1117 Ruijing Building, Maoming South Road,
Shanghai 200020 China

Tel: (86)-21-6415-3935 Fax: (86)-21-6472-6957

<http://www.nitto-kohki.cn/>

NITTO KOHKI Co., Ltd. Shenzhen Representative Office

#0726 International Culture Building, 3039, Shennan
Zhong Rd., Futian District, Shenzhen, 518003 China

Tel: (86)-755-8375-2185 Fax: (86)-755-8375-2187

<http://www.nitto-kohki.cn/>

NITTO KOHKI Co., Ltd. Bangkok Representative Office

38Q, House Convent Bldg, 7th Floor, Unit 7A,
Convent Rd, Silom, Bangkok, 10500 Thailand

Tel: (66)-2-632-0307 Fax: (66)-2-632-0308

http://www.nittobkk.com/eng_index.htm

EC DECLARATION OF CONFORMITY

We hereby declare that the following our product conforms with the essential health and safety requirements of
EEC Directives.

Product: PNEUMATIC RECIPROCATING SANDER

Model: LINE SANDER: LS-10

Serial No: X X X X X

Consecutive numbers (00001~99999)
Christian era's last digit (0~9)

Manufacturer: NITTO KOHKI Co., Ltd.

2-9-4, Nakaikegami, Ohta-ku, Tokyo, 146-8555, Japan

Authorised Compiler in the Community:

Masatoshi Ogue

President

NITTO KOHKI EUROPE Co., Ltd.

Unit21, Empire Centre, Imperial Way, Watford Hertfordshire, WD24 4TS, UK

Tel: (44)-01923-239668 Fax: (44)-01923-248815

Directive: 98/37/EC and 2006/42/EC Machinery Directive

The above product has been evaluated for conformity with above directives using the following European standards.

The technical construction file (TCF) for this product is retained at the above manufacturer's location.

Machinery Directive: EN ISO12100-1:2003, EN ISO12100-2:2003,

EN ISO14121-1:2007, EN792-8:2001+A1:2008, others

Sound Pressure/Power Level: EN ISO15744:2008, EN ISO4871:1996

Vibration Level: EN28662-1:1992, EN ISO8662-8:1997

Name: K. Kishi

Title: GENERAL MANAGER MACHINE TOOLS DIV.

Being the responsible person appointed and employed the manufacturer.