

Pneumatic tool series for automatic machines

Automation of deburring, sanding, scaling and chipping work



**Changing deburring and polishing work
with lightweight, high speed rotation,
and energy saving technologies!**



Precision sanding in tight spots with a 10 mm wide belt

Made to order

Pneumatic Belt Sander

BELTON

Model B-10-RBT-S/B-10-RBT

Deburring Grinding & Sanding

YouTube



Enhances work efficiency with startup failure and belt break detection functions

Achieves high-precision tool exchange using a robotic hand changer from KOSMEK LTD.

Air can be supplied from two locations: the top and the rear.

Equipped with:
- Startup failure detection
- Belt break detection (B-10-RBT-S only)



Mounting example on a 6-axis robot



Precision sanding in tight spots with a 10 mm wide belt

Curved surface grinding possible with the Offset Bracket

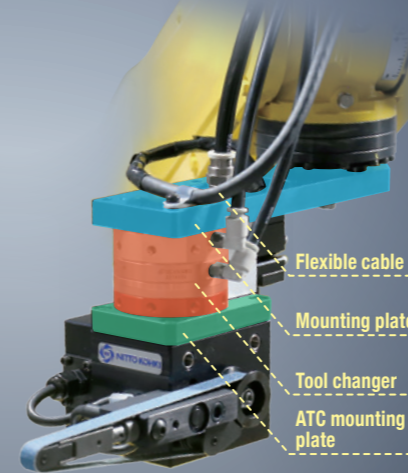

Mounting example on a robot

Mounting Plates for Robots

Required when connecting BELTON to robotic systems. For external dimensions, please refer to Nitto Kohki's website.

Before selecting a plate, please verify using CAD data that there is no interference with the robot during installation.

For ISO Mechanical Interface 2	For ISO Mechanical Interface 4	For YASKAWA MOTOMAN-GP7	Required when using tool changers
Mounting Plate B-10 ISO2 PN: TB11845	Mounting Plate B-10 ISO4 PN: TB11846	Mounting Plate B-10 GP7 PN: TB11847	ATC Mounting Plate B-10 PN: TB11848

Tool Changers



Used to attach and detach robots and tools.
For both B-10-RBT-S/
B-10-RBT (robot side)

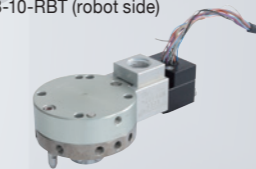

Master Cylinder Ass'y
PN: TB11767

Used to attach and detach robots and tools.
For both B-10-RBT-S/
B-10-RBT (tool side)



Tool Adapter Ass'y
PN: TB11769

Flexible Cable

Cable for external output signal connection to B-10-RBT-S



Flexible Cable (3 m/5 m/8 m) Ass'y
PN: 3 m: TB11771 / 5 m: TB11772 / 8 m: TB11774

External Dimensions (B-10-RBT-S)

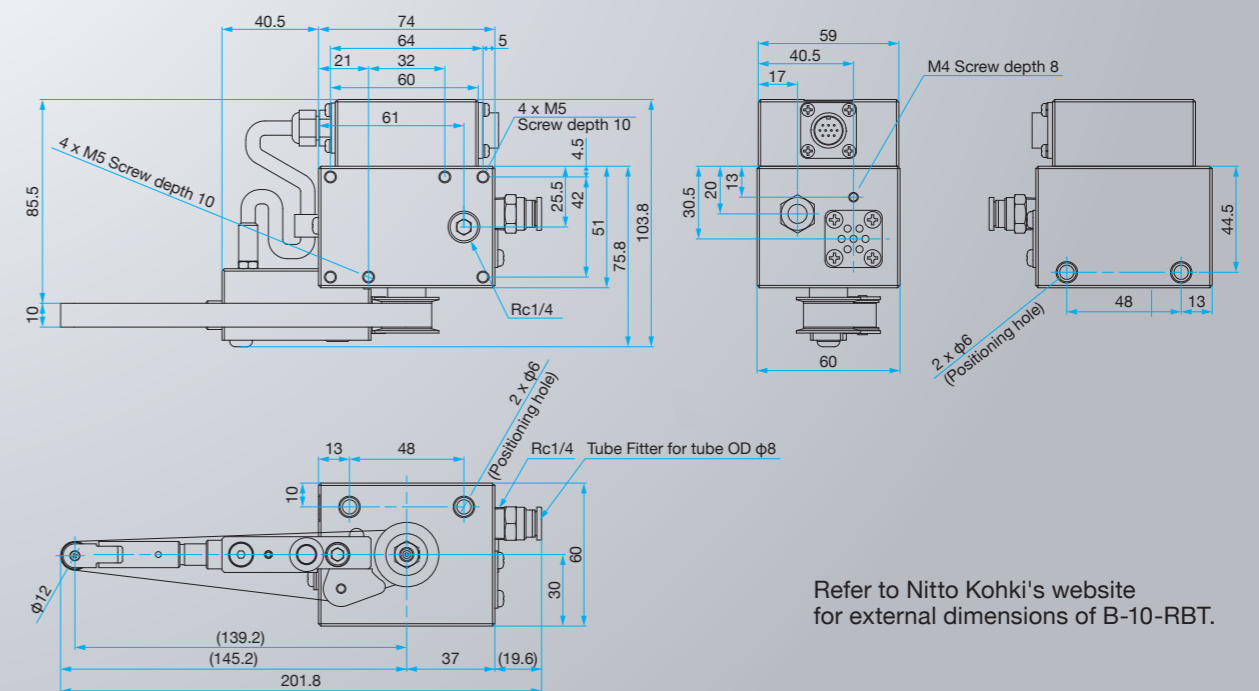

Refer to Nitto Kohki's website for external dimensions of B-10-RBT.

(Unit: mm)

Specifications	B-10-RBT-S	B-10-RBT
Model	B-10-RBT-S	B-10-RBT
Air Pressure	MPa (kgf/cm ²)	0.4 (4)
Air Consumption (No-load)	m ³ /min	0.24
Free Speed	min ⁻¹	15000
Belt Speed	m/min	990
Belt Size	mm	10x330
Air Inlet Size		Rc 1/4
Mass (Weight)	kg	1.0 0.9
Startup failure detection function	○	-
Belt break detection function	○	-
Installed Abrasive Belt	Z #100x10mm	
Accessories Included	<ul style="list-style-type: none"> Abrasive Belt Z #60 x 10 mm, #80 x 10 mm, #100 x 10 mm, #120 x 10 mm 1.5 mm Hex Socket Screw Key Offset Bracket 10 Ass'y (installed): 1 set 	

Optional Accessories	PN		
Grit	Zirconia (Z)	Alumina (AA)	Ceramic (CE)
# 40	—	—	TB10943
# 60	TB10904	—	TB10944
# 80	TB10905	—	TB10945
# 100	TB10906	—	TB10946
# 120	TB10907	—	TB10947
# 180	TB10908	—	—
# 240	TB10909	—	—
# 400	—	TB10936	—
	50 pcs./set	50 pcs./set	50 pcs./set

Optional Parts
PN: TB09997 Offset Bracket 10 Ass'y
PN: TA99155 Idle Pulley 10 Sub Ass'y
PN: TB11598 Bracket 10-RBT Ass'y

Enjoy BELTON's deburring performance on robots

Made to order

Pneumatic Belt Sander

BELTON

Model B-20CL-01

Deburring

Grinding & Sanding

YouTube



B-20CL-01
w/ floating

B-20CL-01
w/o floating

The 20 mm wide belt is suited for deburring curved edges



Compatible with air float attachments available in the market (Mounting Jig is required)

Securely fixed to the robot by using screw holes and positioning pins

Curved surface grinding is possible by using the Offset Bracket

Mounting example on a 6-axis robot

Specifications		B-20CL-01
Model		B-20CL-01
Air Pressure	MPa (kgf/cm ²)	0.6 (6)
Air Consumption (No-load)	m ³ /min	0.52
Free Speed	min ⁻¹	18000
Belt Speed	m/min	2770
Belt Size	mm	20x520
Air Inlet Size		Rc 1/4
Mass (Weight)	kg	1.6
Installed Abrasive Belt		Z #60x20mm
Accessories Included		<ul style="list-style-type: none"> Abrasive Belt Z #60 x 20 mm, #80 x 20 mm, #100 x 20 mm, #120 x 20 mm 2.5 mm Hex Socket Screw Key 4 mm Hex Socket Screw Key Silencer HI CUPLA 20PM Steel Offset Bracket 20 Ass'y (Installed) Bushing R 1/4 x NPT 1/4

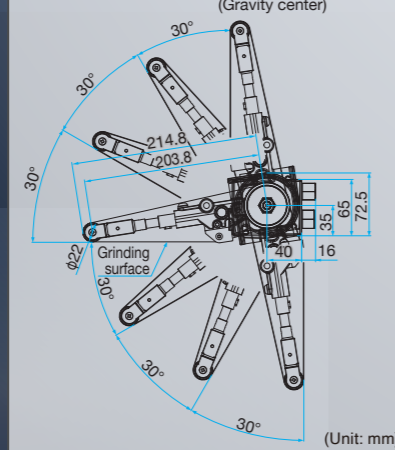
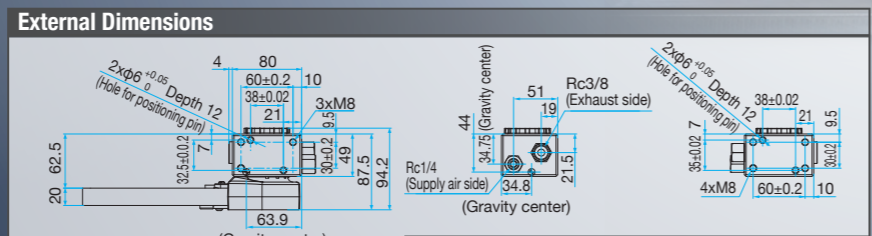

Grit	Optional Accessories		
	Zirconia (Z)	Alumina (AA)	Ceramic (CE)
#40	TB10910	-	TB10948
#60	TB10911	-	TB10949
#80	TB10912	-	TB10950
#100	TB10913	-	TB10951
#120	TB10914	-	TB10952
#180	TB10915	-	-
#240	TB10916	-	-
#320	-	TB10937	-
#400	-	TB10938	-
Sales Unit	20 pcs./set	20 pcs./set	20 pcs./set

Optional Parts	
PN: TB10192 Offset Bracket 20 Ass'y	PN: TB10160 Idle Pulley Bracket Ass'y

Suitable for deburring complex-shaped workpieces

Made to order

Pneumatic Die Grinder

AIR SONIC

Model L-35C-02

Deburring

Grinding

YouTube



High-speed rotation realized by unique air motor



Compatible with air float attachments available in the market

Accepts various mounted wheels and rotary carbide burrs with 6 mm shanks

40 mm body diameter makes it easy to mount on robots

Mounting example on a 6-axis robot

Specifications		L-35C-02
Model		L-35C-02
Air Pressure	MPa (kgf/cm ²)	0.6 (6)
Air Consumption (No-load)	m ³ /min	0.35
Free Speed	min ⁻¹	37500
Chuck Size	mm	φ6
Mass (Weight)	kg	1.1
Accessories Included		<ul style="list-style-type: none"> 2 pieces of 14 mm Single Ended Spanner Bushing R 1/4 x NPT 1/4 HI CUPLA 20PM Steel (Installed)

Optional Accessories
PN: TP02806
Chuck Sleeve for 3 mm diameter



Tip tools with 3 mm shaft can be mounted.

Sales Unit: 1 piece

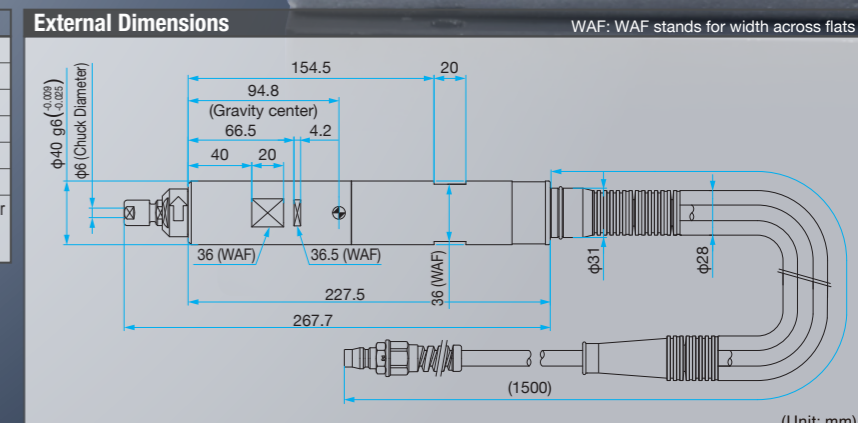

PN: TB11198 Rotary Burr No.1: CB1C-106 63	PN: TB11199 Rotary Burr No.2: CB2C-105 63	PN: TB11200 Rotary Burr No.3: CB3C-103 63	PN: TB11201 Rotary Burr No.4: CB4C-103 63	PN: TB11202 Rotary Burr No.5: CB5C-104 64	PN: TB11203 Rotary Burr No.6: CB6C-102 60	PN: TB11204 Rotary Burr No.7: CB7C-103 75	PN: TB11205 Rotary Burr No.8: CB8C-105 54
---	---	---	---	---	---	---	---

From rough grinding to finishing

Made to order

Pneumatic Double Action Sander

ORBITAL SANDER Model APS-125-01

Surface sanding



Double action movement reduces swirl patterns

Example of floating function by using air cylinder and linear guide (Not included)



Mounting example on a 6-axis robot



Securely fixed to the robot by using screw holes and positioning pins

Realize a uniform sanding by using an intermediate pad

Specifications		Model	APS-125-01
Air Pressure	MPa (kgf/cm ²)		0.6 (6)
Air Consumption (No-load)	m ³ /min		0.45
Free Speed	min ⁻¹		11000
Orbit Diameter	mm		5
Paper Size	mm		125 (5")
Mass (Weight)	kg		1.5
Accessories Included	<ul style="list-style-type: none"> • 2 pieces of Abrasive Paper #80 (Velcro) • 2 pieces of Abrasive Paper #120 (Velcro) • 17 mm Single Ended Spanner • Silencer • HI CUPLA 20PM Steel • Bushing R1/4 x NPT 1/4 		

Optional Accessories		
PN	Description	Sales Unit
TB03649	Pad 5" (Velcro type with hole)	1 set
TB03697	Pad 5" (Velcro type without hole)	
TB03882	Pad 5" (Leather type with hole)	
TB03879	Pad 5" (Leather type without hole)	50 pcs./set
TA99542	Abrasive Paper #40 (Velcro)	
TA99543	Abrasive Paper #60 (Velcro)	
TA99544	Abrasive Paper #80 (Velcro)	
TA99545	Abrasive Paper #100 (Velcro)	
TA99546	Abrasive Paper #120 (Velcro)	
TA99547	Abrasive Paper #150 (Velcro)	
TA99548	Abrasive Paper #180 (Velcro)	
TA99549	Abrasive Paper #240 (Velcro)	
TA99550	Abrasive Paper #320 (Velcro)	
TA99551	Abrasive Paper #400 (Velcro)	

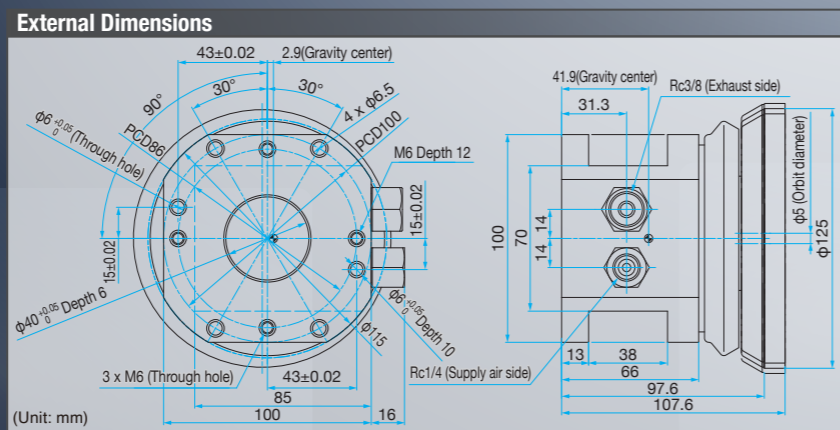

Enables efficient chipping operations

Made to order

Pneumatic Needle Scaler

JET CHISEL Model JT-16-RBT

Scaling Chipping



Low vibration and reaction force reduce impact on robots

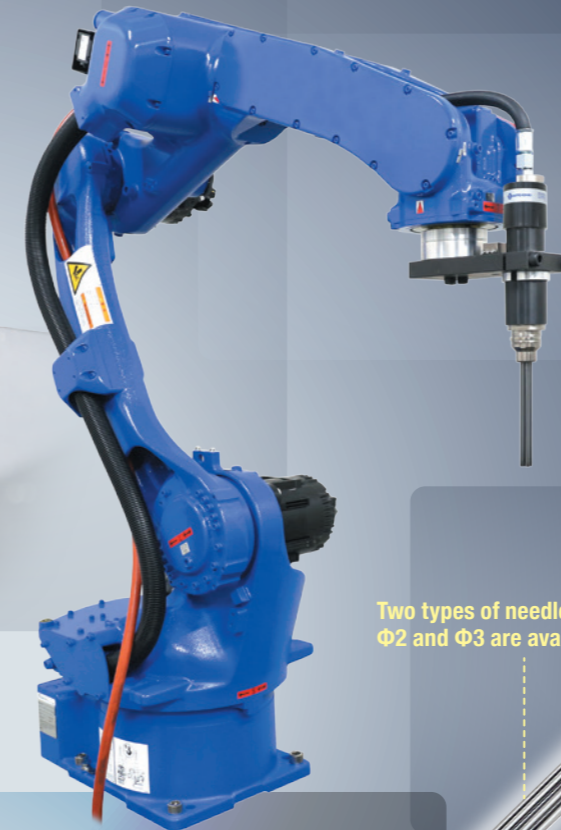

Mounting example on a 6-axis robot

Two types of needles, φ2 and φ3 are available

Floating mechanism reduces reaction force to the robot

Specifications		Model	JT-16-RBT
Air Pressure	MPa (kgf/cm ²)		0.6 (6)
Air Consumption (No-load)	m ³ /min		0.16
Strokes per Minute (when using dia. 2 mm needles)	min ⁻¹		5740
Needle Diameter and Quantity	2 mm dia./pcs.		15
	3 mm dia./pcs.		6
Needle Length	mm		180
Mass (Weight)	kg		1.8
Accessories Included	<ul style="list-style-type: none"> • 15 pieces of 2 mm x 180 mm Needles (Installed) • 15 pieces of 2 mm x 180 mm Needles • 6 pieces of 3 mm x 180 mm Needles • Needle supporter 3 mm • Bushing R 3/8 x NPT 3/8 • Hose Nipple R 3/8 x NPT 3/8 		

Optional Accessories		
PN	Description	Sales Unit
TB11054	2 mm x 180 mm Needles	100 pcs./set
TB11055	3 mm x 180 mm Needles	
TB10878	2 mm x 180 mm Needles (Stainless Steel)	30 pcs./set
TB10877	3 mm x 180 mm Needles (Stainless Steel)	
TQ15316	Needle Supporter 2 mm	1 piece
TQ15315	Needle Supporter 3 mm	

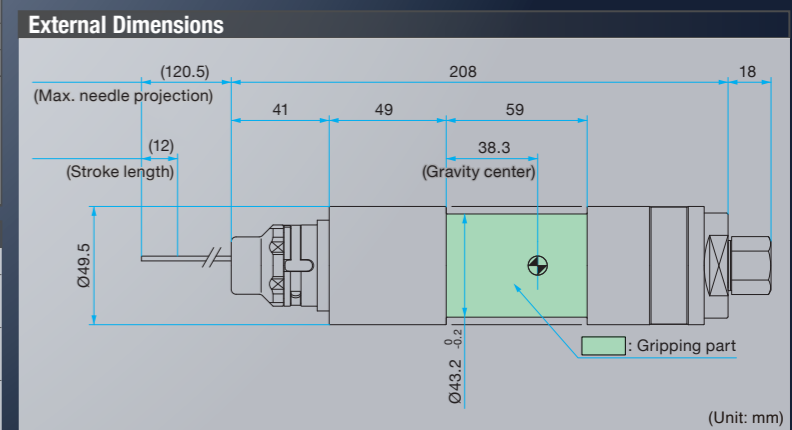
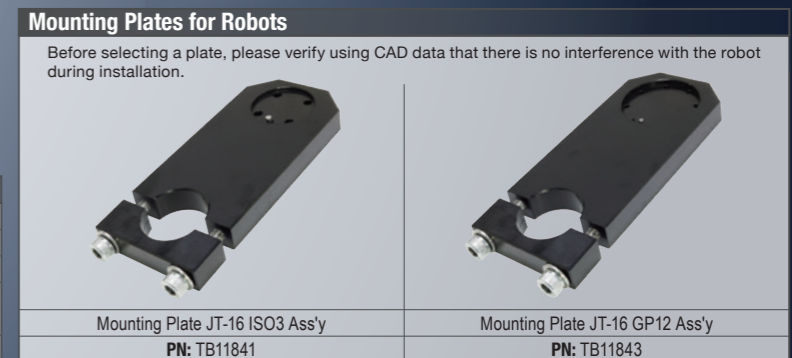

Introduction of automation related products

delvo

"delvo" Brushless Type C Series (Current control type) DLV45C/DLV70C

30 different torque settings on a single screwdriver



DLV45C12L DLV70C06P

Special website



YouTube



[Example of installation on a robot]

Compatible with desktop robots, Cartesian coordinate robots and 6-axis robots



[Features]

- Current controlled torque system
- Low-voltage brushless motor
- ESD (Electrostatic Discharge) protection structure
- For hand-held / external start (for automatic machines)
- Nine speed settings available
- Automatic three step speed control function
- Two types of measuring methods (Time / Motor rotation signal)
- Seven color indication LED (At the tip of the screwdriver)
- Two external I/O signal connection ports (NPN and PNP switchable, RS-232C)
- Various settings can be configured via a PC (Free setting software available on Nitto Kohki website)
- Built-in screw counting function

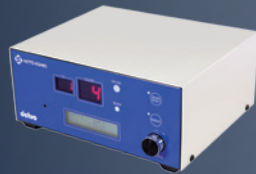

Controller
DCC0241X-AZ

LINEAR

Electric Vacuum End Effector e-VEE

Switch from ejector to vacuum pump for energy-saving vacuum lifting



YouTube



Power consumption

MAX 0.014 kWh*

*Maximum instantaneous value during operation.

e-VEE
EVE-500

[Example of installation on a robot]



[Application Examples]

Warehouses



Food factories



Agricultural sectors

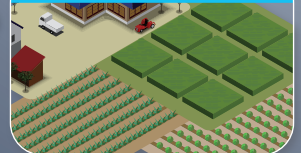

[Features]

- Energy saving (Pump automatically stops at preset pressure)
- Vacuum holding function (Valve maintains vacuum when the pump stops automatically)
- Suitable for use anywhere (No compressed air required)
- Easy setup (No need for hose routing)
- Quiet operation (No air discharge noise)
- Cleanliness (No external air inflow)
- I/O signal type (PNP / NPN models available)

NITTO KOHKI CO., LTD.

Web www.nitto-kohki.co.jp/e/

Head Office

2-9-4, Nakaikegami, Ota-ku, Tokyo 146-8555, Japan
Tel : +81-3-3755-1111 Fax : +81-3-3753-8791
E-mail : overseas@nitto-kohki.co.jp



DISTRIBUTED BY